

**PARTS  
CATALOGUE  
CATALOGO  
DE REPUESTOS**

**T105E (5AM3) ARGENTINA**

**T105E (5AM4) MEXICO**

T105E  
PARTS CATALOGUE  
E2002 by Yamaha Motor Co., Ltd.  
1st Edition, May 2002  
All rights reserved.  
Any reprinting or unauthorized use  
without the written permission of  
Yamaha Motor Co., Ltd.  
is expressly prohibited.  
Printed in Japan

T105E  
CATALOGO DE REPUESTOS  
E2002 Yamaha Motor Co., Ltd.  
1ª edición, Mayo 2002  
Reservados todos los derechos.  
Se prohíbe expresamente toda reimpresión  
o utilización no autorizada de este manual  
sin el consentimiento por escrito de  
Yamaha Motor Co., Ltd.  
Impreso en Japón

# FOREWORD

This Parts Catalogue is related to the parts for the model(s) in the below frame. When you are ordering replacement parts, please refer to this Parts Catalogue and quote both part numbers and part names correctly.

T105E(5AM3/5AM4)

1. Modifications or additions which have been made after issue of the Parts Catalogue will be announced in the Yamaha Parts News.  
It is advisable that you make necessary corrections to the Parts Catalogue according to the Yamaha Parts News.

2. Abbreviations

The following abbreviations are used in this Parts Catalogue.

“UR” Use specified parts number.

“UN” Use as many as needed.

“AP” Alternate Parts

“LM” Local Made (Parts need to be ordered locally)

“F#” Frame No. (Applicable machine No.)

3. Parts, which are to be supplied in an assembly, are listed with a dot(.) in front of the part name as shown below.

EXAMPLE

CARBURETOR ASSY

.JET, PILOT

.NOZZLE, MAIN

4. Number of component for assembly

The numeral appearing to the right of each component part indicates the quantity of parts for each assembly unit.

EXAMPLE

PART NO.	DESCRIPTION	Q'TY	REMARKS
2F5-83310-60	FRONT FLASHER LIGHT ASSY	2	
115-83311-60	.BULB (6V-18W)	1	

5. Applicable colors of graphics are represented in the “REMARKS” as shown below.

PART NO.	DESCRIPTION	Q'TY	REMARKS
2N4-24110-00-X5	FUEL TANK COMP.	1	MXR
3J1-24240-10	.GRAPHIC, FUEL TANK	1	FOR MXR

6. Applicable Serial No. and Color Code

Frame Serial No.

Engine Serial No.

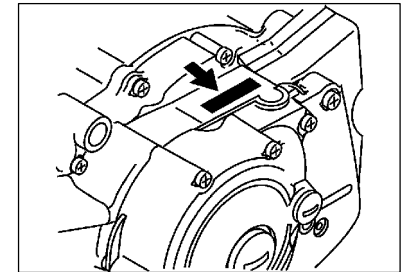
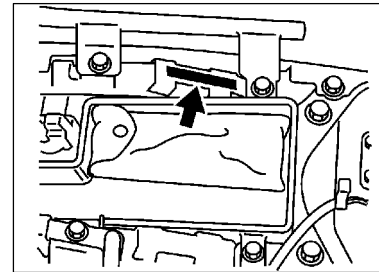

Color Code	Color Name	Abbreviation
0033	YAMAHA BLACK	YB
00MW	BLUISH BLACK	BIB
0121	VIVID RED COCKTAIL 7	VRC7

7. Note that the illustration for reference in finding parts numbers, not to be used for assembling. When assembling, please use the applicable service manual.
8. The asterisk (\*) before a reference number indicates modification items after the first edition.

# PROLOGO

Este Catálogo de Repuestos corresponde a las piezas para el(los) modelo(s) del recuadro siguiente. Al formular el pedido de repuestos, se ruega citar este Catálogo de Repuestos y especificar correctamente los números de parte y los nombres de parte.

T105E(5AM3/5AM4)

- Las modificaciones y agregados que se hayan realizado después de la edición de este Catálogo de Repuestos, serán anunciados en las Informaciones de Recambios Yamaha.
- Abreviaciones  
En este Catálogo de Repuestos se emplean las siguientes abreviaciones.  
"UR" Usar el número de partes especificado  
"UN" Usar la cantidad necesaria  
"AP" Piezas sustitutivas  
"LM" Fabricación local (Partes necesarias que se pedirán localmente)  
"F#" No. de bastidor aplicable
- Las piezas suministradas como conjunto se describen con un punto (.) que precede al nombre de la pieza como se indica a continuación.

#### EJEMPLO

CONJUNTO CARBURADOR  
.INYECTOR, piloto  
.BOQUILLA, principal

- Cantidad de componentes de un conjunto  
La numeración que aparece a la derecha de cada descripción, indica la cantidad de piezas por cada unidad de conjunto.

#### EJEMPLO

PIEZAS NO.	DESCRIPCION	CANT.	OBSERVACION
2F5-83310-60	ENSAMBLAJE DE LA LUZ	2	
115-83311-60	.BOMBILLA (6V-1 8W)	1	
1M1-83309-60	.REFLECTOR	1	

- Los colores de los componentes se indican como sigue en la columna de "OBSERVACIONES".

#### EJEMPLO

PIEZAS NO.	DESCRIPCION	CANT.	OBSERVACION
2N4-24110-00-X5	COMP. DEL TANQUE	1	MXR
3J1-24240-10	.GRAFICO, DEL TANQUE	1	PARA MXR

- Números de Serie y Códigos de Color aplicables

No. de Serie del motor.
No. de Serie del bastidor

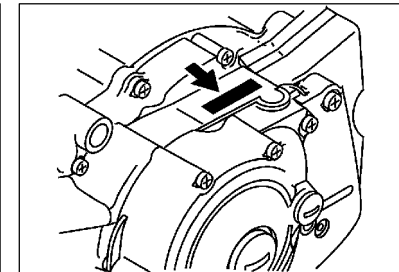
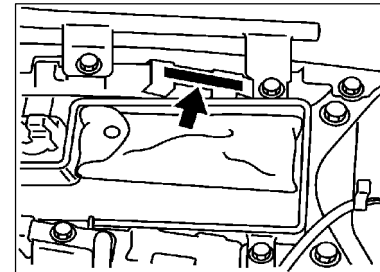

Código de Color	Nombre del Color	Abreviación
0033	YAMAHA BLACK	YB
00MW	BLUISH BLACK	BIB
0121	VIVID RED COCKTAIL 1	VRC1

- Debe tenerse en cuenta que las ilustraciones sirven como guía para la búsqueda de las referencias y no deben usarse para el montaje. Durante el montaje, se recomienda usar el manual de Taller correspondiente.
- EL asterisco (\*) antes del número de referencia indica los elementos modificados después de la primera edición.

# CONTENTS

## ENGINE

CYLINDER HEAD .....	1
CRANKSHAFT. PISTON .....	2
VALVE .....	3
CAMSHAFT. CHAIN .....	4
OIL PUMP .....	5
INTAKE .....	6
CARBURETOR .....	7
EXHAUST .....	8
CRANKCASE .....	9
CRANKCASE COVER 1 .....	10
STARTER .....	11
STARTER CLUTCH .....	12
CLUTCH .....	13
TRANSMISSION .....	14
SHIFT CAM. FORK .....	15
SHIFT SHAFT .....	16

## CHASSIS

FRAME .....	17
FENDER .....	18
SIDE COVER .....	19
REAR ARM. SUSPENSION .....	22
STEERING .....	23
FRONT FORK .....	25
FUEL TANK .....	27
SEAT .....	28
FRONT WHEEL .....	29
FRONT BRAKE CALIPER .....	30
REAR WHEEL .....	31

STEERING HANDLE. CABLE .....	33
FRONT MASTER CYLINDER .....	35
STAND. FOOTREST .....	36
LEG SHIELD .....	38
GENERATOR .....	40
STARTING MOTOR .....	41
FLASHER LIGHT .....	42
METER .....	43
HEADLIGHT .....	44
TAILLIGHT .....	45
HANDLE SWITCH. LEVER .....	46
ELECTRICAL 1 .....	47
ELECTRICAL 2 .....	48

## INDEX

NUMERICAL INDEX .....	49
-----------------------	----

# CONTENIDO

## MOTOR

CULATA DE CILINDRO .....	1
CIGUENAL. PISTON .....	2
VALVULA .....	3
ARBOL DE LEV. CADENA .....	4
BOMBA DE ACEITE .....	5
ADMISION .....	6
CARBURADOR .....	7
DESCARGA .....	8
CARTER .....	9
CUBIERTA DE CARTER 1 .....	10
ARRANQUE .....	11
EMBRAG. DEL ARRANQUE .....	12
EMBRAGUE .....	13
TRANSMISION .....	14
LEVA DE CAMBIO. HORQ .....	15
EJE DE CAMBIO. PEDAL .....	16

## SHASIS

CUADRO .....	17
GUARDABARRO .....	18
CUBIERTA LATERAL .....	19
BRAZO TRASERO. SUSPENSION .....	22
DIRECCION .....	23
HORQUILLA DELANTERA .....	25
DEPOSITO DE COMBUSTIBLE .....	27
ASIENTO .....	28
RUEDA DELANTERA .....	29
CALIBRE FRENO DELANTERA .....	30
RUEDA TRASERA .....	31

MANUBRIO. CABLE .....	33
CILINDRO MAESTRO DELANTERO .....	35
SOPORTE. APOYAPIE .....	36
PATA PROTEGIDA .....	38
GENERADOR .....	40
MOTOR DE ARRANQUE .....	41
LUZ DE DESTELLADOR .....	42
MEDIDOR .....	43
FARO DELANTERO .....	44
LUZ DE COLA .....	45
INTERRUPTOR DE MANIJA. PALANCA .....	46
EQUIPO ELECTRICO 1 .....	47
EQUIPO ELECTRICO 2 .....	48

## INDICE

INDICE NUMERICO .....	49
-----------------------	----

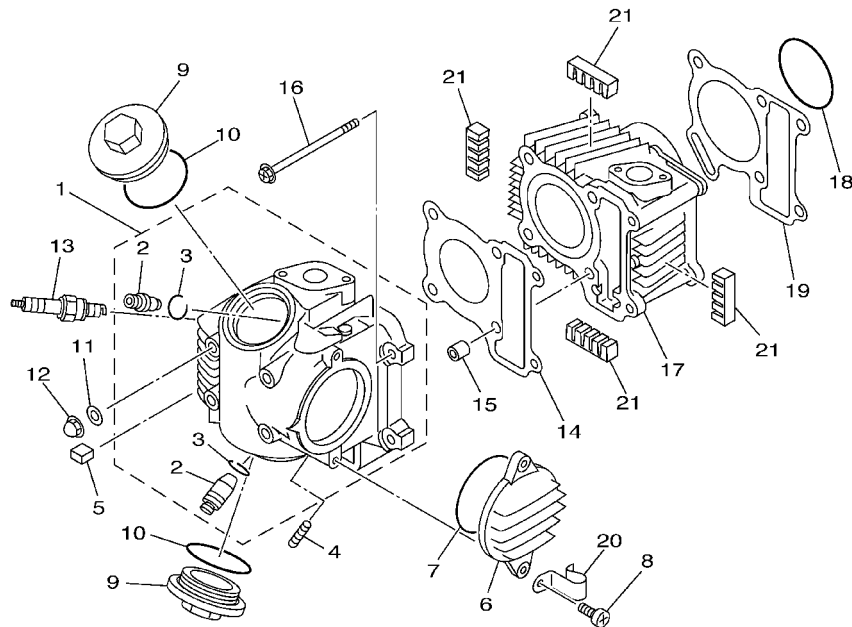

5AM3200-9010

FIG. 1 CYLINDER HEAD

CULATA DE CILINDRO

REF. NO.	PART NO. CODIGO NO.	DESCRIPTION DESCRIPTION	5AM3	5AM4	REMARKS OBSERVACION
1	4ST-E1102-00	CYLINDER HEAD ASSY CULATA DE CILINDRO COMPLETA	1	1	
2	4ST-11134-11	.GUIDE, EXHAUST VALVE .GUIA VALV.DE ESC.	2	2	
3	93440-10153	.CIRCLIP .SEGURO	2	2	
4	22F-14651-00	BOLT PERNO	2	2	
5	4ST-E1161-00	ABSORBER 1 AMORTIGUADOR 1	8	8	
6	4ST-E1185-00	COVER, CYLINDER HEAD SIDE 1 CUBIERTA CULATA CIL.LAT.1	1	1	
7	93210-638G6	O-RING JUNTA TORICA	1	1	
8	98507-06016	SCREW TORNILLO DE CABEZA CON PLANA	2	2	
9	4ST-E1186-00	COVER, CYLINDER HEAD SIDE 2 CUBIERTA CULATA CIL.LAT.2	2	2	
10	93210-448G4	O-RING JUNTA TORICA	2	2	
11	90201-08609	WASHER, PLATE ARANDELA PLANA	4	4	
12	90176-08026	NUT, CROWN TUERCA CORONA	4	4	
13	94700-00828	PLUG SPARK (NGK C7HSA) BUJIA (NGK C7HSA)	1	1	UR
	94700-00829	PLUG SPARK (ND U22FS-U) BUJIA (ND U22FS-U)	1	1	UR
14	4ST-E1181-00	GASKET, CYLINDER HEAD 1 JUNTA DE CULATA 1	1	1	
15	99530-10114	PIN, DOWEL PASADOR, DE CLAVIJA	2	2	
16	95027-06090	BOLT, FLANGE PERNO, DE BRIDA	2	2	
17	4ST-E1310-00	CYLINDER CILINDRO	1	1	
18	93210-568G8	O-RING JUNTA TORICA	1	1	
19	4ST-E1351-01	GASKET, CYLINDER JUNTA, DE CILINDRO	1	1	
20	90465-08230	CLAMP BRIDA	1	1	
21	4ST-E1162-00	ABSORBER 2 AMORTIGUADOR 2	4	4	

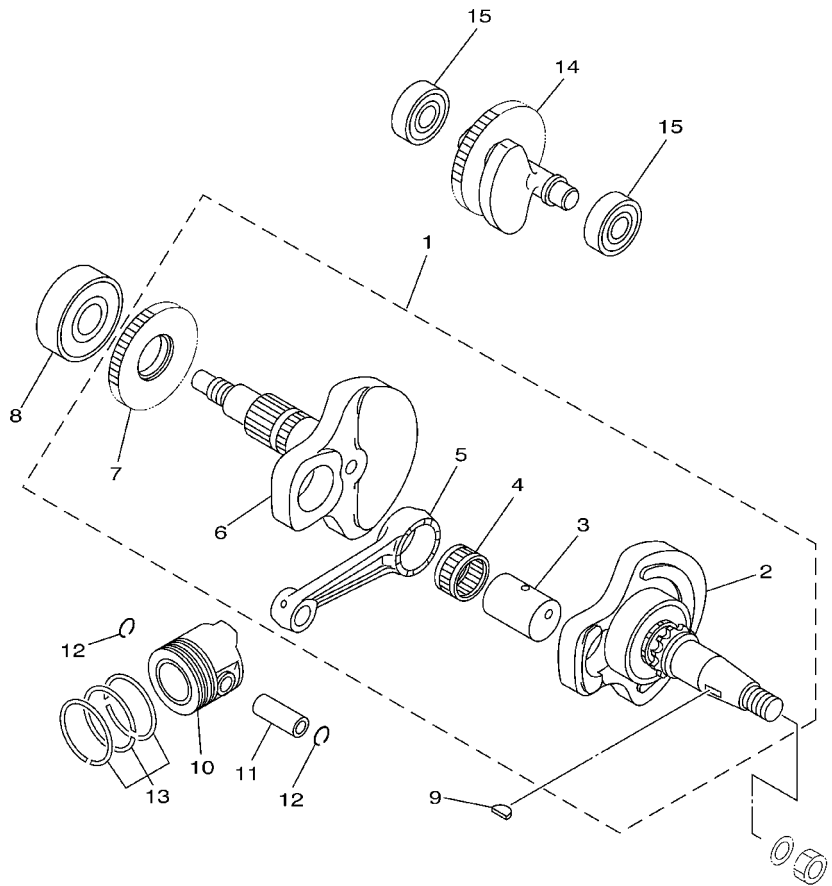

4ST1460-6020

FIG. 2 CRANKSHAFT. PISTON CIGUENAL. PISTON

REF. NO.	PART NO. CODIGO NO.	DESCRIPTION DESCRIPTION	5AM3	5AM4	REMARKS OBSERVACION
1	4ST-E1400-03	CRANKSHAFT ASSY CIGUENAL COMPLETO	1	1	
2	4ST-E1412-00	.CRANK 1 MANIVELA 1	1	1	
3	4GL-11681-00	.PIN, CRANK 1 PASADOR MANIVELA 1	1	1	
4	93310-326M9	.BEARING COJINETE DE RODILLOS	1	1	
5	4ST-11651-00	.ROD, CONNECTING BIELA	1	1	
6	4ST-E1422-00	.CRANK 2 MANIVELA 2	1	1	
7	4ST-11536-00	.GEAR, DRIVE ENGRANAJE TRACCION	1	1	
8	93306-20595	BEARING COJINETE	1	1	
9	90280-03017	KEY, WOODRUFF CUNA WOODRUFF	1	1	
10	4ST-E1631-00	PISTON (STD) PISTON (STD)	1	1	
	4ST-E1635-00	PISTON (0.25MM O/S) PISTON (0.25MM O/S)	1	1	AP
	4ST-E1636-00	PISTON (0.50MM O/S) PISTON (0.50MM O/S)	1	1	AP
	4ST-E1637-00	PISTON (0.75MM O/S) PISTON (0.75MM O/S)	1	1	AP
	4ST-E1638-00	PISTON (1.00MM O/S) PISTON (1.00MM O/S)	1	1	AP
11	22K-11633-01	PIN, PISTON PASADOR, PISTON	1	1	
12	93450-14088	CIRCLIP SEGURO	2	2	
13	50M-E1610-00	PISTON RING SET (STD) JUEGO DE AROS (NORMA)	1	1	
	50M-11604-00	PISTON RING SET (0.25MM O/S) JUEGO DE ANILLOS (0.25MM O/S)	1	1	AP
	50M-11610-20	PISTON RING SET (0.50MM O/S) JUEGO DE AROS (0.50MM O/S)	1	1	AP
	50M-11606-00	PISTON RING SET (0.75MM O/S) JUEGO DE ANILLOS (0.75MM O/S)	1	1	AP
	50M-11610-40	PISTON RING SET (1.00MM O/S) JUEGO DE AROS (1.00MM O/S)	1	1	AP
14	4ST-11500-03	BALANCER ASSY COMPENSADOR COMPLETA	1	1	
15	93306-20229	BEARING COJINETE	2	2	

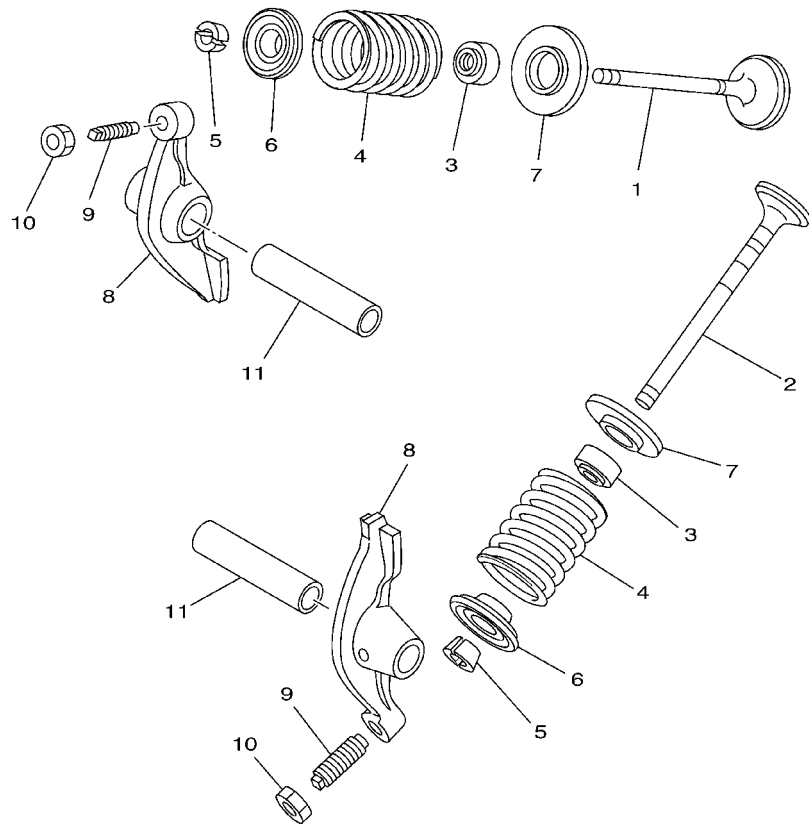

FIG. 3 VALVE

VALVULA

REF. NO.	PART NO. CODIGO NO.	DESCRIPTION DESCRIPTION	5AM3	5AM4	REMARKS OBSERVACION
1	4GL-12111-01	VALVE, INTAKE VALVULA DE ADMISION	1	1	
2	4GL-12121-00	VALVE, EXHAUST VALVULA DE ESCAPE	1	1	
3	4SV-12119-00	SEAL, VALVE STEM SELLO DE ACEITE VALVULA	2	2	
4	4GL-12114-00	SPRING, VALVE OUTER RESORTE VALVULA EXTERIOR	2	2	
5	1WG-12118-00	COTTER, VALVE SEGURO DE VALVULA	4	4	
6	3UH-12117-00	RETAINER, VALVE SPRING RETEN RESORTE DE VALVULA	2	2	
7	3GM-12126-00	SEAT, VALVE SPRING 2 ASIENTO RESORTE DE VALVULA2	2	2	
8	50M-12151-00	ARM, VALVE ROCKER BRAZO DE BALANCIN DE VALVULA	2	2	
9	22F-12159-00	SCREW, VALVE ADJUSTING TORNILLO DE AJUSTE DE VALVULA	2	2	
10	90170-05302	NUT TUERCA	2	2	
11	22F-12156-00	SHAFT, ROCKER 2 EJE DE BALANCIN 2	2	2	



4ST1460-6030

FIG. 4 CAMSHAFT. CHAIN

ARBOL DE LEV. CADENA

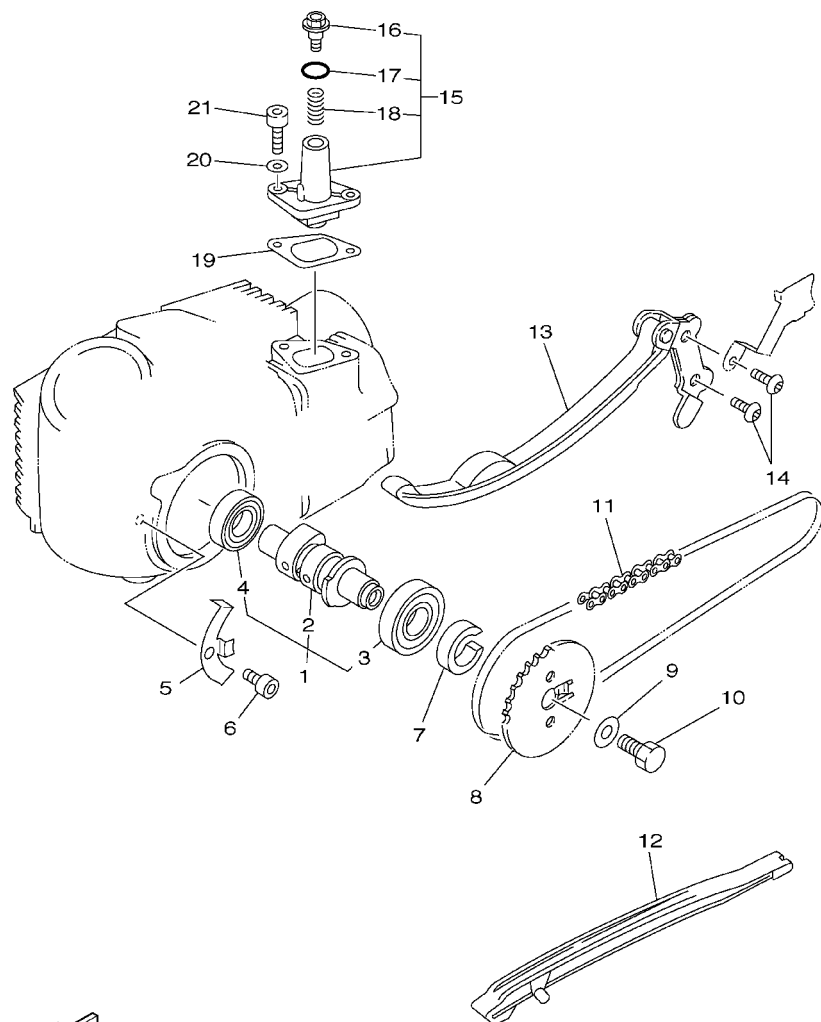

REF. NO.	PART NO. CODIGO NO.	DESCRIPTION DESCRIPTION	5AM3	5AM4	REMARKS OBSERVACION
1	4ST-E2170-01	CAMSHAFT ASSY 1 ARBOL DE LEVAS COMPLETO 1	1	1	
2	4ST-12171-01	.CAMSHAFT 1 .ARBOL DE LEVAS 1	1	1	
3	93306-00308	.BEARING (B6003) .COJINETE (B6003)	1	1	
4	93306-00210	.BEARING .COJINETE	1	1	
5	4ST-E111F-00	PLATE PLACA	1	1	
6	91317-06012	BOLT PERNO	1	1	
7	90387-167L5	COLLAR COLLAR	1	1	
8	4ST-E2176-00	SPROCKET, CAM CHAIN CATALINA DE CADENA	1	1	
9	90201-08326	WASHER, PLATE ARANDELA PLANA	1	1	
10	90101-08590	BOLT TORNILLO	1	1	
11	94568-63084	CHAIN CADENA	1	1	
12	4ST-12231-00	GUIDE, STOPPER 1 TOPE DE GUIA 1	1	1	
13	4ST-12241-00	GUIDE, STOPPER 2 TOPE DE GUIA 2	1	1	
14	91317-06016	BOLT PERNO	2	2	
15	4ST-12210-00	TENSIONER ASSY, CAM CHAIN TENSOR CADENA DE LEVA	1	1	
16	4ST-12228-00	BOLT .PERNO	1	1	
17	4ST-12223-00	.O-RING .ANILLO O	1	1	
18	4ST-12216-00	.SPRING .RESORTE	1	1	
19	4ST-E2213-00	GASKET, TENSIONER CASE EMPAQUE DE CAJA TENSOR	1	1	
20	90430-06014	GASKET JUNTA	2	2	
21	91317-06016	BOLT PERNO	2	2	



5AM3200-9040

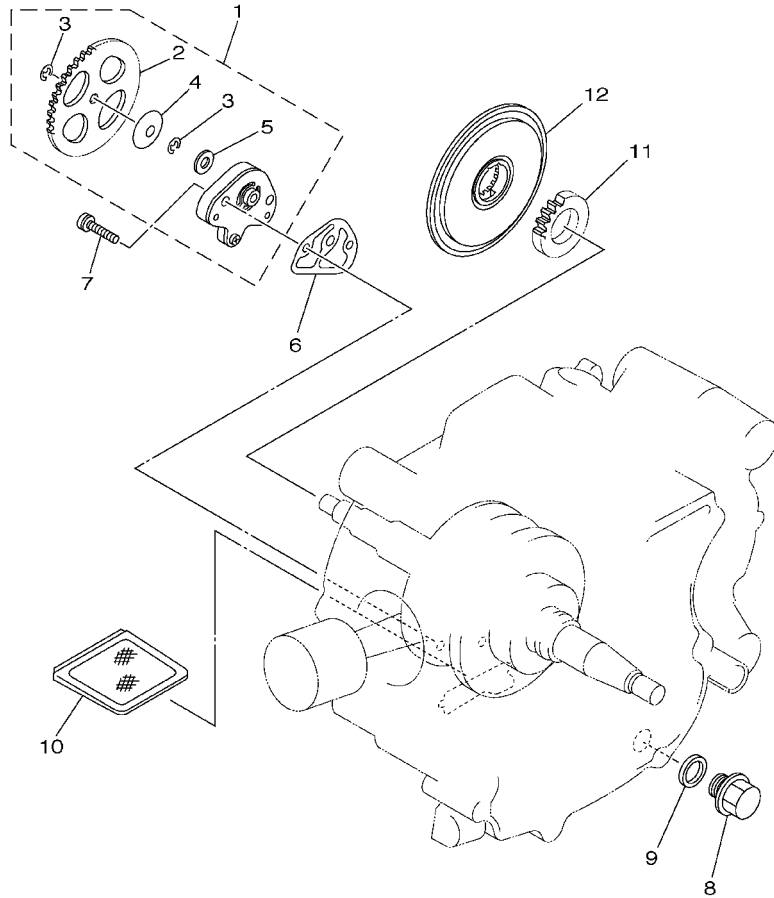

5AM3200-9050

FIG. 5 OIL PUMP

BOMBA DE ACEITE

REF. NO.	PART NO. CODIGO NO.	DESCRIPTION DESCRIPTION	5AM3	5AM4	REMARKS OBSERVACION
1	4GL-13300-00	OIL PUMP ASSY BOMBA DE ACEITE COMPLETA	1	1	
2	46J-13325-00	.GEAR, PUMP DRIVEN .ENGRANAJE IMPULSOR DE BOMBA	1	1	
3	99001-05600	.CIRCLIP .PRESILLA REDONDA	2	2	
4	90208-07052	.WASHER, CONICAL SPRING .ARANDELA DE RESORTE CONICO	1	1	
5	90201-07641	.WASHER, PLATE .ARANDELA PLANA	1	1	
6	4ST-E3329-00	GASKET, PUMP COVER EMPAQUE TAPA DE BOMBA	1	1	
7	90155-06007	SCREW, FLAT FILLISTER TORNILLO CABEZA PLANA RAN.	2	2	
8	90340-12059	PLUG, STRAIGHT SCREW TORNILLO, DE DRENAJE	1	1	
9	90430-12812	GASKET JUNTA	1	1	
10	4ST-E3411-00	STRAINER, OIL FILTRO DE ACEITE	1	1	
11	4ST-13324-00	GEAR, PUMP DRIVE ENGRANAJE TRACC. DE BOMBA	1	1	
12	4GL-13451-01	FILTER, ROTARY FILTRO	1	1	

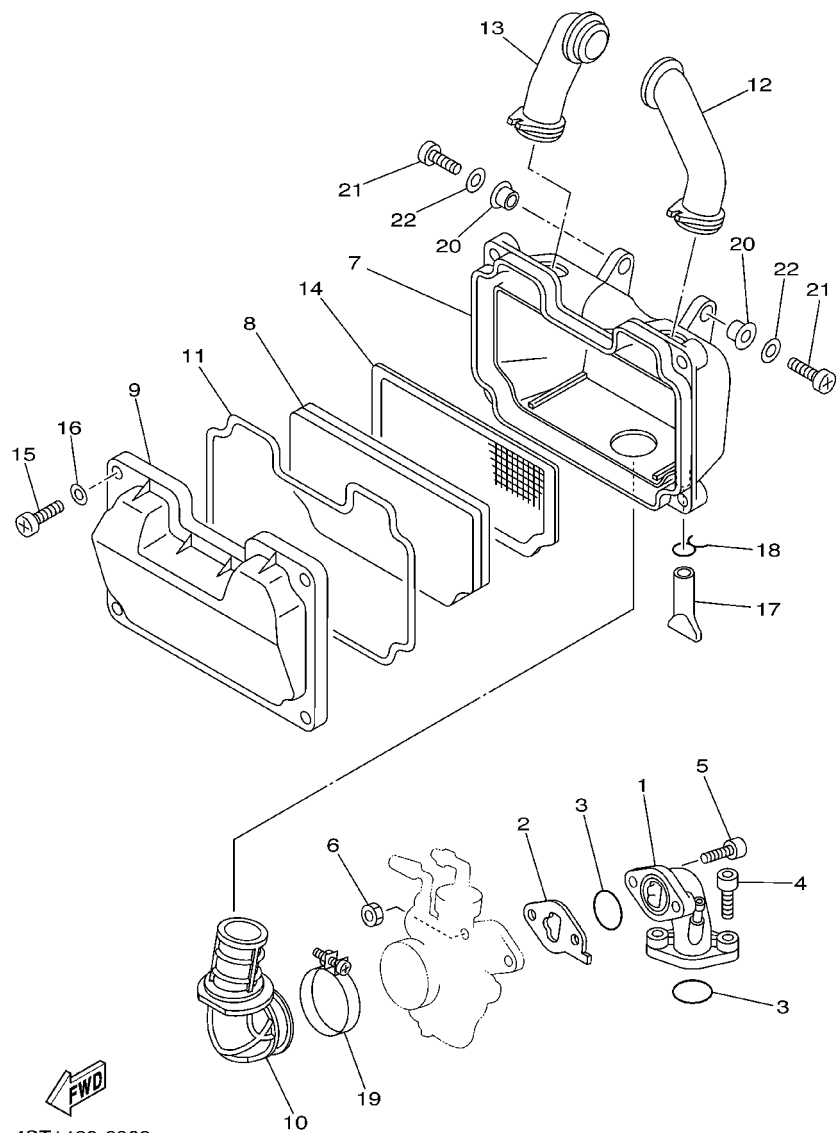

4ST1460-6060

FIG. 6 INTAKE

ADMISION

REF. NO.	PART NO. CODIGO NO.	DESCRIPTION DESCRIPTION	5AM3	5AM4	REMARKS OBSERVACION
1	4ST-13586-01	JOINT, CARBURETOR 1 TOBERA DE CARBURADOR 1	1	1	
2	4ST-13595-00	JOINT TOBERA	1	1	
3	93210-258G2	O-RING JUNTA TORICA	2	2	
4	91317-06025	BOLT PERNO	2	2	
5	91317-06025	BOLT PERNO	2	2	
6	95317-06700	NUT TUERCA	2	2	
7	4ST-E4411-00	CASE, AIR CLEANER 1 CAJA FILTRO DEL AIRE 1	1	1	
8	4ST-E4451-01	ELEMENT, AIR CLEANER ELEMENTO DEL FILTRO DEL AIRE	1	1	
9	4ST-E4412-00	CAP, CLEANER CASE 1 TAPA CAJA DEL FILTRO 1	1	1	
10	4ST-E4453-00	JOINT, AIR CLEANER 1 UNION DEL FILTRO DEL AIRE 1	1	1	
11	4ST-E4452-00	SEAL SELLO	1	1	
12	4ST-E4423-00	PIPE, SUCTION 1 TUBO DE SUCCION 1	1	1	
13	4ST-E4433-00	PIPE, SUCTION 2 TUBO DE SUCCION 2	1	1	
14	4ST-E4472-01	PLATE, ELEMENT PLACA DE ELEMENTO	1	1	
15	98507-05030	SCREW TORNILLO DE CABEZA CON PLANA	4	4	
16	92907-05600	WASHER, PLATE ARANDELA	4	4	
17	4ST-E443E-00	PIPE, DRAIN TUBO, DRENAJE	1	1	
18	90467-11106	CLIP PRESILLA	1	1	
19	90460-43053	CLAMP, HOSE BRIDA, DE UNION	1	1	
20	90387-068J7	COLLAR COLLAR	2	2	
21	98517-06020	SCREW, PAN HEAD TORNILLO DE CABEZA CON PLANA	2	2	
22	92907-06600	WASHER, PLATE ARANDELA	2	2	

FIG. 7 CARBURETOR

CARBURADOR

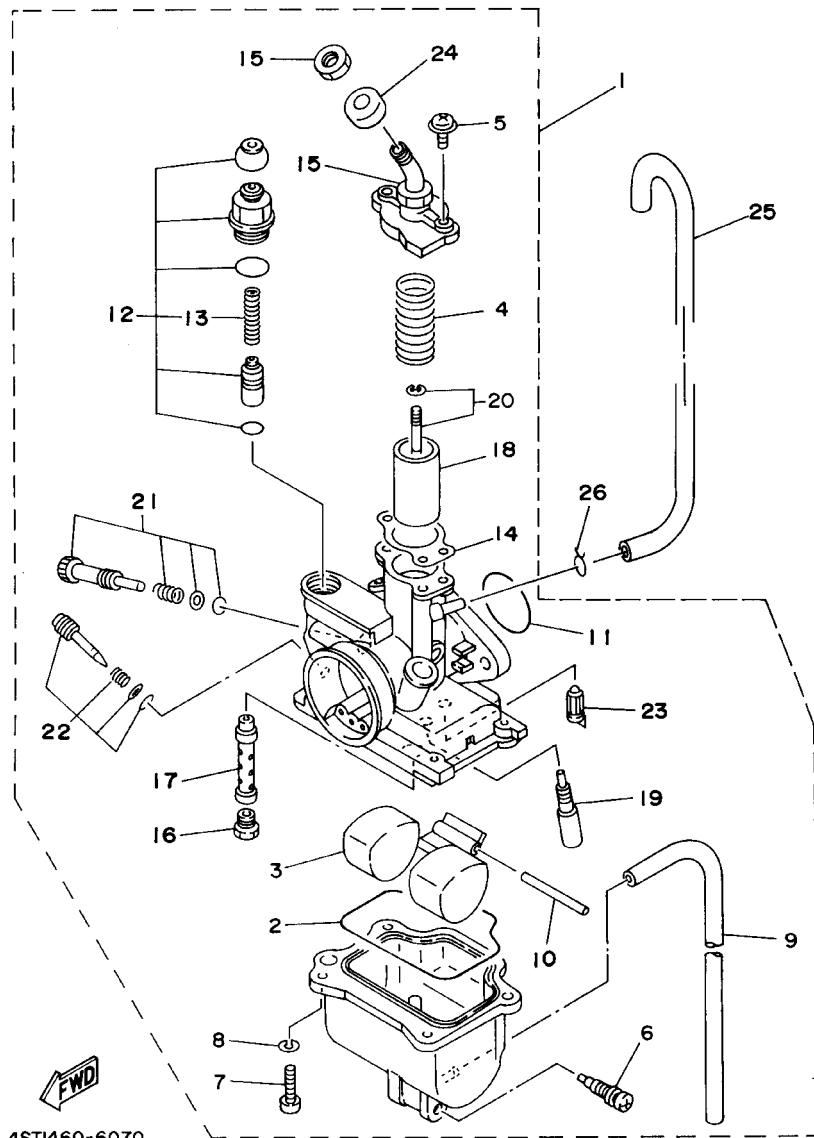

4STI460-6070

REF. NO.	PART NO. CODIGO NO.	DESCRIPTION DESCRIPTION	5AM3	5AM4	REMARKS OBSERVACION
1	4ST-14101-01	CARBURETOR ASSY 1 CARBURADOR COMPLETO 1	1	1	
2	4GL-14239-00	.SEAL .SELLO	1	1	
3	4GL-14185-00	.FLOAT .BOYA	1	1	
4	3XG-14133-00	.SPRING, THROTTLE STOP .RESORTE TOPE DE ACELERACION	1	1	
5	4GL-14565-00	.SCREW .TORNILLO	2	2	
6	12R-14191-00	.PLUG, DRAIN .TORNILLO, DE DRENAJE	1	1	
7	98507-04014	.SCREW .TORNILLO DE CABEZA CON PLANA	4	4	
8	92907-04100	.WASHER, SPRING .ARANDELA DE RESORTE	4	4	
9	4GL-14348-00	.PIPE 1 .MANGUERA 1	1	1	
10	353-14186-00	.PIN, FLOAT .PASADOR DE LA BOYA	1	1	
11	241-14147-00	.O-RING .ANILLO O	1	1	
12	4GL-1410A-00	.STARTER SET .JUEGO DE ARRANQUE	1	1	
13	127-14135-00	.SPRING, PLUNGER .RESORTE EMBOLO	1	1	
14	4NM-14198-00	.GASKET .EMPAQUE	1	1	
15	802-14161-00	.NUT, CABLE ADJUSTING .TUERCA AJUSTADOR DE CABLE	2	2	
16	18A-14143-18	.JET, MAIN (# 90) .SURTIDOR, PRINCIPAL (# 90)	1	1	
17	4GL-14141-15	.NOZZLE, MAIN .BOQUILLA PRINCIPAL	1	1	
18	4NM-14112-30	.VALVE, THROTTLE 1 .VALVULA DE ACELERACION 1	1	1	
19	3KD-14142-15	.JET, PILOT (# 15) .SURTIDOR DE RALENTI (# 15)	1	1	
20	4ST-1490J-00	.NEEDLE SET .CJTO, AGUJA	1	1	
21	4GL-14103-00	.THROTTLE SCREW SET .CJTO. TORNILLO DEL RALENTI	1	1	
22	5DW-14104-00	.AIR SCREW SET .CJTO. TORNILLO DE AIRE	1	1	
23	7LG-14150-11	.NEEDLE ASSY .AGUJA DEL CARB.	1	1	
24	132-14173-00	.COVER, PLUNGER CAP .CUBIERTA TAPA DE EMBOLO	1	1	
25	4ST-E4197-00	PIPE TUBO RESPIRADERO	1	1	
26	90467-08003	CLIP PRESILLA	1	1	

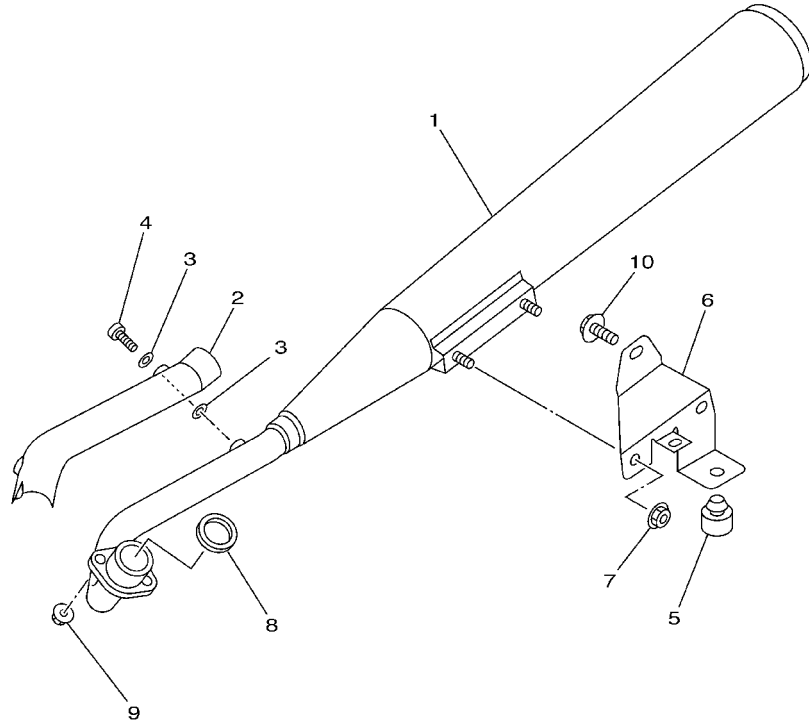

**FWD**  
4ST1460-6080

**FIG. 8 EXHAUST**

**DESCARGA**

REF. NO.	PART NO. CODIGO NO.	DESCRIPTION DESCRIPTION	5AM3	5AM4	REMARKS OBSERVACION
1	4ST-E4711-00-93	MUFFLER 1 SILENCIADOR 1	1	1	CHROME PLATED
2	4ST-E4628-00-93	PROTECTOR, EXHAUST PIPE PROTECTOR DE TUBO DE ESCAPE	1	1	CHROME PLATED
3	4BD-14766-00	WASHER, PROTECTOR ARANDELA DE PROTECTOR	4	4	
4	98980-06008	SCREW, BIND TORNILLO DE AJUSTE	2	2	
5	4ST-F7114-00	STOPPER, MAIN STAND TOPE DE PUNTAL PRINCIPAL	1	1	
6	4ST-E4781-00-WN	STAY, MUFFLER 2 SOPORTE DE ESCAPE 2	1	1	CIRCUIT SILVER
7	95707-08500	NUT, FLANGE TUERCA DE BRIDA	2	2	
8	4ST-E4613-00	GASKET, EXHAUST PIPE JUNTA, TUBO DE ESCAPE	1	1	
9	95707-06500	NUT, FLANGE TUERCA DE BRIDA	2	2	
10	95817-08016	BOLT, FLANGE TUERCA DE REBORDE	1	1	



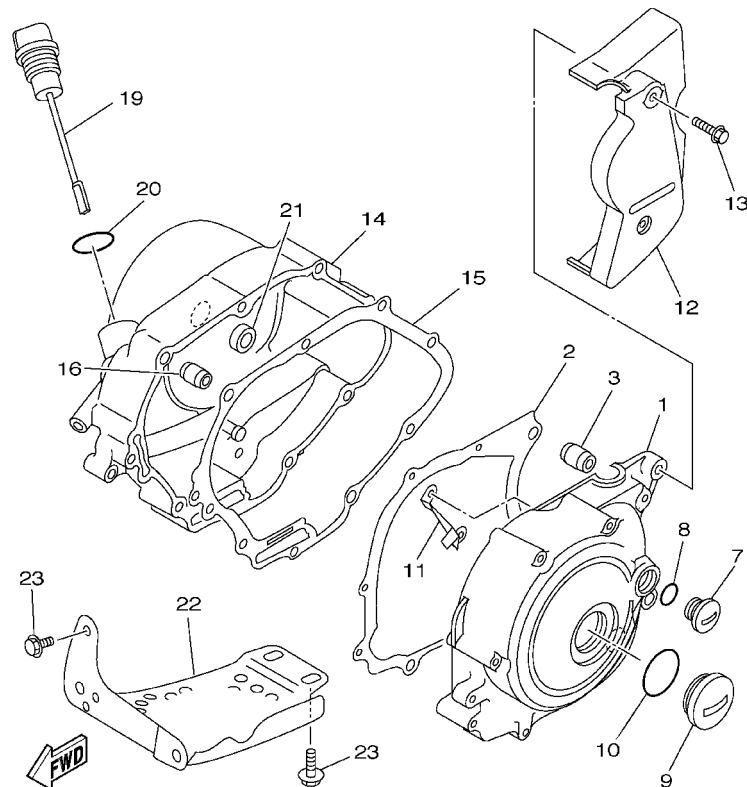
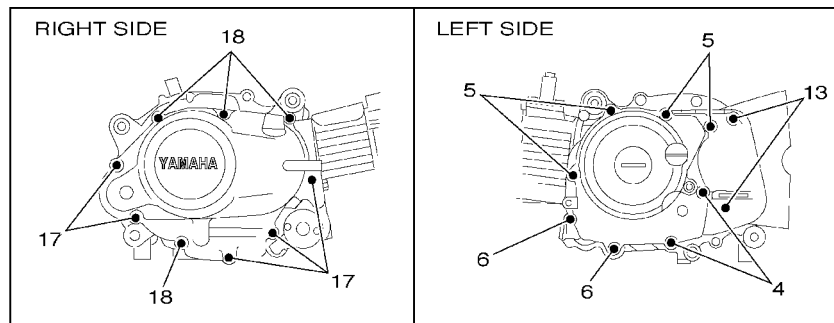

5AM3200-9100

FIG. 10 CRANKCASE COVER 1

CUBIERTA DE CARTER 1

REF. NO.	PART NO. CODIGO NO.	DESCRIPTION DESCRIPTION	5AM3	5AM4	REMARKS OBSERVACION
1	4ST-E5411-00-WN	COVER, CRANKCASE 1 CUBIERTA DE CARTER 1	1	1	CIRCUIT SILVER
2	4ST-E5451-00	GASKET, CRANKCASE COVER 1 EMPAQ DE CUBIERTA DE CARTER 1	1	1	
3	99530-10114	PIN, DOWEL PASADOR, DE CLAVIJA	2	2	
4	98507-06040	SCREW TORNILLO DE CABEZA CON PLANA	2	2	
5	98507-06050	SCREW TORNILLO DE CABEZA CON PLANA	4	4	
6	98507-06080	SCREW TORNILLO DE CABEZA CON PLANA	2	2	
7	90340-14810-WN	PLUG, STRAIGHT SCREW TORNILLO, DE DRENAJE	1	1	CIRCUIT SILVER
8	93210-148F8	O-RING JUNTA TORICA	1	1	
9	90340-32812-WN	PLUG, STRAIGHT SCREW TORNILLO, DE DRENAJE	1	1	CIRCUIT SILVER
10	93210-328G3	O-RING JUNTA TORICA	1	1	
11	4ST-E5113-00	PLATE PLACA	1	1	
12	4ST-E5418-00-WN	COVER, CHAIN CASE CUBIERTA CAJA DE CADENA	1	1	CIRCUIT SILVER
13	98517-06025	SCREW, PAN HEAD TORNILLO DE CABEZA CON PLANA	2	2	
14	4ST-E5421-00-WN	COVER, CRANKCASE 2 TAPA DE CARTER DERECHA 2	1	1	CIRCUIT SILVER
15	4ST-E5461-00	GASKET, CRANKCASE COVER 2 JUNTA TAPA CARTER DRCHO 2	1	1	
16	99530-10114	PIN, DOWEL PASADOR, DE CLAVIJA	2	2	
17	98507-06040	SCREW TORNILLO DE CABEZA CON PLANA	5	5	
18	98507-06050	SCREW TORNILLO DE CABEZA CON PLANA	4	4	
19	4ST-E5362-00	PLUG, OIL LEVEL TAPON DEL NIVEL DE ACEITE	1	1	
20	93210-198F9	O-RING JUNTA TORICA	1	1	
21	93101-10843	OIL SEAL RETEN DE ACEITE	2	2	
22	4ST-E5436-00	COVER, STARTING MOTOR CUBIERTA DE MOTOR DE ARRANQUE	1	1	
23	95827-08016	BOLT, FLANGE TUERCA DE REBORDE	2	2	



4UL1440-7111

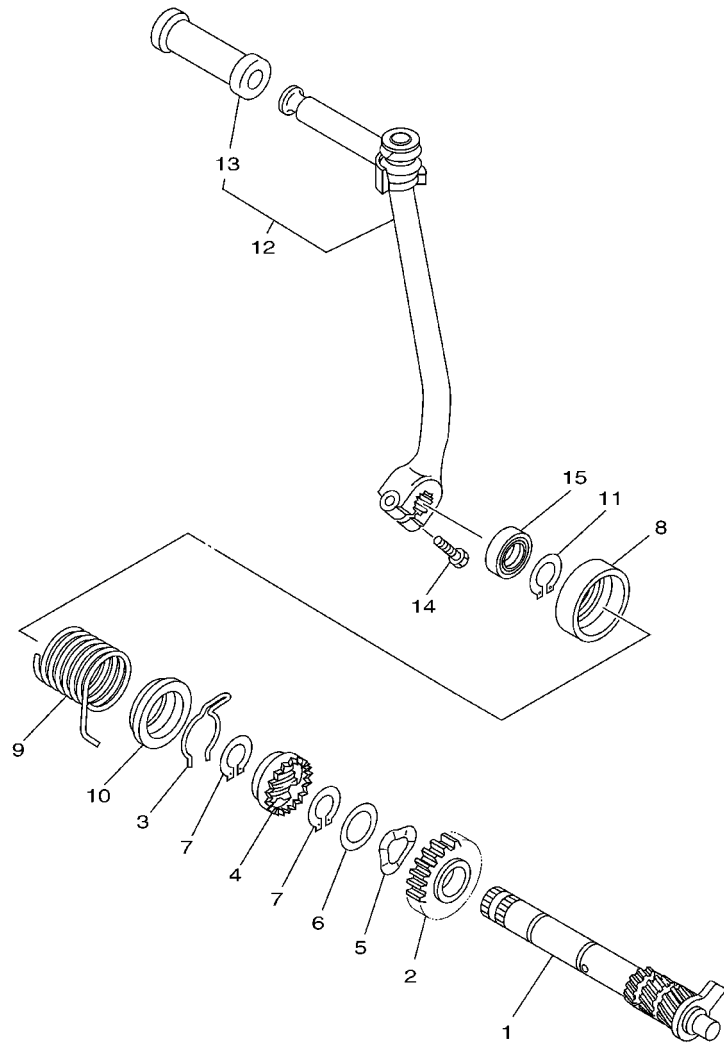
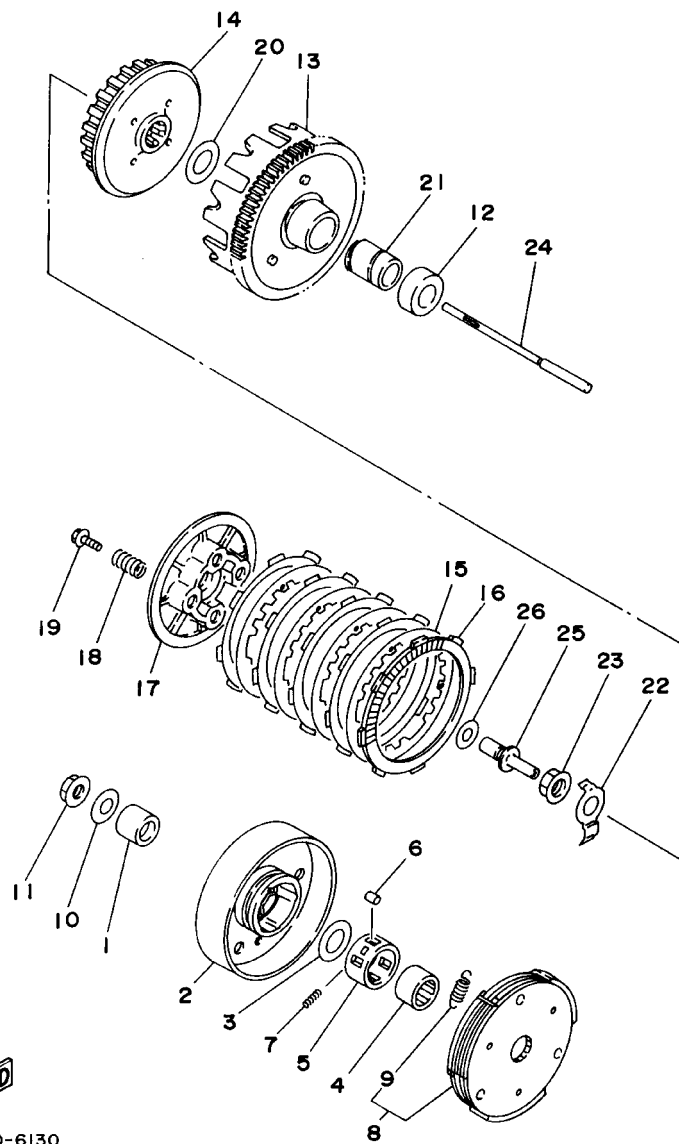

FIG. 11 STARTER

ARRANQUE

REF. NO.	PART NO. CODIGO NO.	DESCRIPTION DESCRIPTION	5AM3	5AM4	REMARKS OBSERVACION
1	4ST-15660-00	KICK AXLE ASSY EJE DEL PEDAL DE ARRAN.COMPLET	1	1	
2	4ST-15641-00	GEAR, KICK (18T) ENGRANAJE PEDAL ARRANQUE(18T)	1	1	
3	90468-23194	CLIP PRESILLA	1	1	
4	296-15671-00	WHEEL, RATCHET RUEDA DE TRINQUETE	1	1	
5	90206-19027	WASHER, WAVE ARANDELA ONDULADA	1	1	
6	296-15644-00	SHIM CUNA	1	1	
7	99009-19400	CIRCLIP PRESILLA REDONDA	2	2	
8	4ST-E5676-00-92	COVER, SPRING CUBIERTA DE RESORTE	1	1	YELLOW CHROME
9	90508-263A8	SPRING, TORSION RESORTE DE TORSION	1	1	
10	4ST-E5664-00-92	GUIDE, SPRING GUIA DE RESORTE	1	1	YELLOW CHROME
11	99009-15400	CIRCLIP PRESILLA REDONDA	1	1	
12	4ST-E5620-00	KICK CRANK ASSY MANIVELA DE PEDAL COMPLETA	1	1	
13	1EG-E5618-00	.COVER, KICK LEVER .GOMA PROTECTORA, PEDAL	1	1	
14	97017-06025	BOLT PERNO	1	1	
15	93102-15890	OIL SEAL RETEN DE ACEITE	1	1	





4ST1460-6130

FIG. 13 CLUTCH

EMBRAGUE

REF. NO.	PART NO. CODIGO NO.	DESCRIPTION DESCRIPTION	5AM3	5AM4	REMARKS OBSERVACION
1	90560-16385	SPACER SEPARADOR	1	1	
2	4ST-16611-00	CLUTCH HOUSING COMP. CAJA DE EMBRAGUE COMPLETO	1	1	
3	90201-167P7	WASHER, PLATE ARANDELA PLANA	1	1	
4	4GL-16512-00	BOSS, CLUTCH HOUSING COPA DE CAJA DE EMBRAGUE	1	1	
5	4ST-16586-00	CAGE MEDITOR	1	1	
6	93606-10227	PIN, DOWEL PASADOR DE CLAVIJA	3	3	
7	90501-047H5	SPRING, COMPRESSION RESORTE DE COMPRESION	2	2	
8	4ST-16620-00	CLUTCH CARRIER ASSY PORTADOR DE EMBRAGUE COMPLETO	1	1	
9	4ST-16626-00	.SPRING, CLUTCH WEIGHT 1 .RESORTE CONTRAPESO EMBRAGUE 1	3	3	
10	90201-122H1	WASHER, PLATE ARANDELA PLANA	1	1	
11	90179-12659	NUT TUERCA	1	1	
12	90560-17384	SPACER SEPARADOR	1	1	
13	4ST-16150-00	PRIMARY DRIVEN GEAR COMP. CAMPANA DE EMBRAGUE	1	1	
14	2JG-16371-00	BOSS, CLUTCH CUBO, DE EMBRAGUE	1	1	
15	2JG-16324-00	PLATE, CLUTCH 1 PLACA DE EMBRAGUE 1	4	4	
16	3YR-16321-00	PLATE, FRICTION PLACA DE FRICCION	5	5	
17	2JG-16351-01	PLATE, PRESSURE 1 PLATO DE PRESION 1	1	1	
18	90501-217J8	SPRING, COMPRESSION RESORTE DE COMPRESION	4	4	
19	90119-05001	BOLT, WITH WASHER TORNILLO CON ARANDELA	4	4	
20	90201-174L9	WASHER, PLATE ARANDELA PLANA	1	1	
21	90560-17328	SPACER SEPARADOR	1	1	
22	90215-14321	WASHER, LOCK ARANDELA DE CIERRE	1	1	
23	90179-14469	NUT TUERCA	1	1	
24	4ST-16357-00	ROD, PUSH 2 VARILLA DE EMPUJE 2	1	1	
25	2JG-16356-00	ROD, PUSH 1 VARILLA DE EMPUJE 1	1	1	
26	90201-10774	WASHER, PLATE ARANDELA PLANA	1	1	

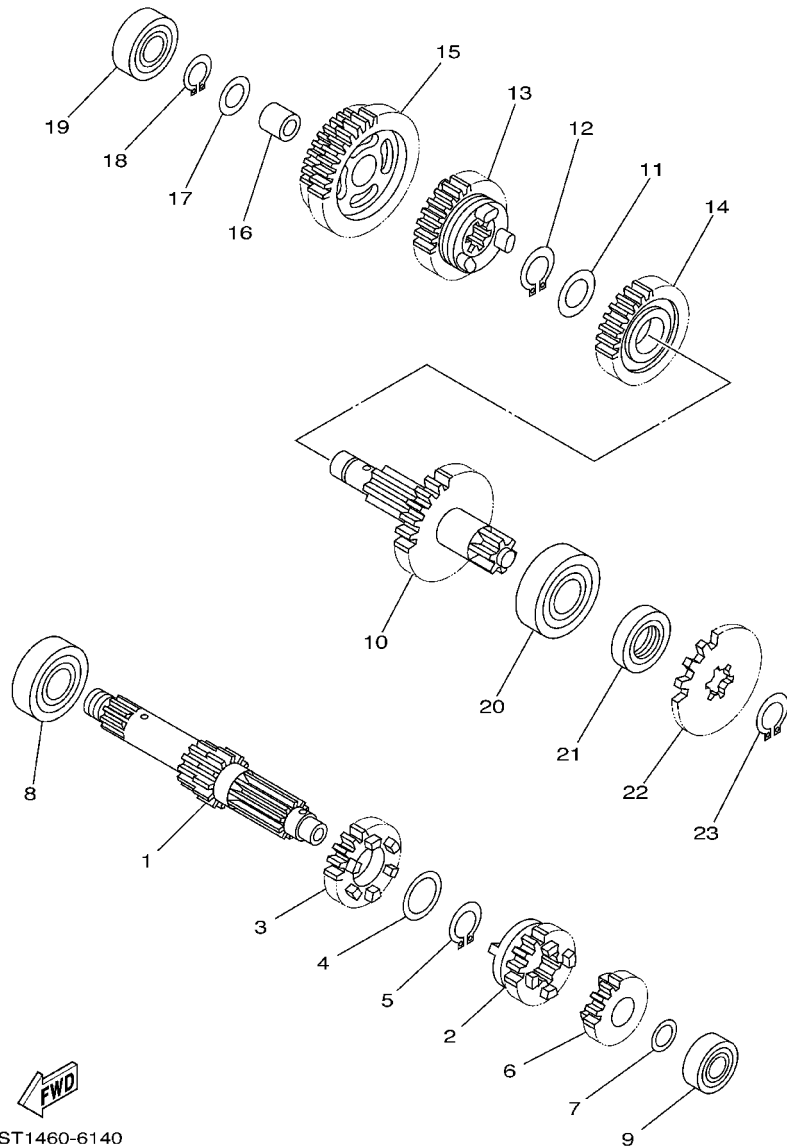

4ST1460-6140

FIG. 14 TRANSMISSION

TRANSMISSION

REF. NO.	PART NO. CODIGO NO.	DESCRIPTION DESCRIPTION	5AM3	5AM4	REMARKS OBSERVACION
1	4ST-17411-00	AXLE, MAIN EJE PRIMARIO	1	1	
2	4ST-17131-00	GEAR, 3RD PINION (21T) ENGRANAJE PINON DE 3RA (21T)	1	1	
3	4ST-17141-00	GEAR, 4TH PINION (21T) ENGRANAJE PINON DE 4TA (21T)	1	1	
4	90201-20266	WASHER, PLATE (T=1.0) ARANDELA, PLACA (T=1.0)	1	1	
5	93410-20038	CIRCLIP SEGURO	1	1	
6	4ST-17121-00	GEAR, 2ND PINION (17T) ENGRANAJE DE PINON DE 2DA (17T)	1	1	
7	90201-12166	WASHER, PLATE ARANDELA PLANA	1	1	
8	93306-203X3	BEARING COJINETE	1	1	
9	93306-001Y1	BEARING COJINETE	1	1	
10	4ST-17402-01	DRIVE AXLE ASSY EJE DE TRACCION COMPLETO	1	1	
11	90201-20266	WASHER, PLATE (T=1.0) ARANDELA, PLACA (T=1.0)	1	1	
12	93410-20038	CIRCLIP SEGURO	1	1	
13	4ST-17241-00	GEAR, 4TH WHEEL (23T) ENGRANAJE DE RUEDA 4TA (23T)	1	1	
14	4ST-17231-00	GEAR, 3RD WHEEL (29T) ENGRANAJE RUEDA DE 3RA (29T)	1	1	
15	4ST-17211-00	GEAR, 1ST WHEEL (30/38T) ENGRANAJE RUEDA DE 1 RA (30/38T)	1	1	
16	90387-1503D	COLLAR COLLAR	1	1	
17	90201-15700	WASHER, PLATE ARANDELA PLANA	1	1	
18	93440-15012	CIRCLIP SEGURO	1	1	
19	93306-202X8	BEARING COJINETE	1	1	
20	93306-204Y7	BEARING COJINETE	1	1	
21	93102-20892	OIL SEAL RETEN DE ACEITE	1	1	
22	93822-15069	SPROCKET, DRIVE (15T) RUEDA DENTADA (15T)	1	1	
23	93410-20038	CIRCLIP SEGURO	1	1	

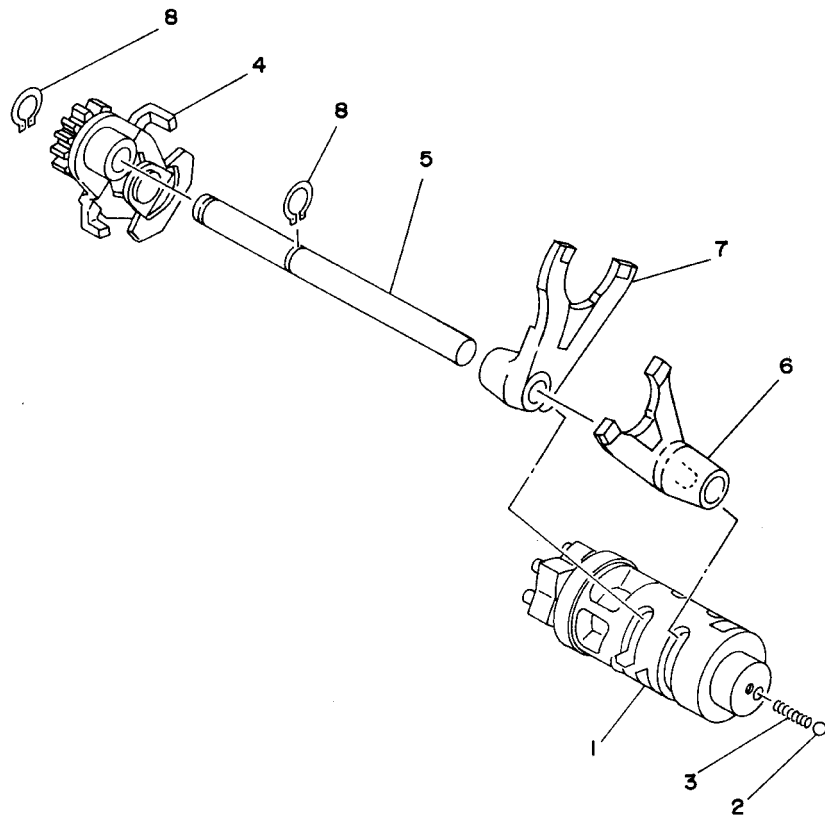

**FWD**  
4STI460-6150

**FIG. 15 SHIFT CAM. FORK**

**LEVA DE CAMBIO. HORQ**

REF. NO.	PART NO. CODIGO NO.	DESCRIPTION DESCRIPTION	5AM3	5AM4	REMARKS OBSERVACION
1	4ST-18540-01	SHIFT CAM ASSY LEVADEL CAMBIO COMPLETA	1	1	
2	4BA-18542-00	POINT, NEUTRAL PUNTO MVERTO	1	1	
3	90501-06022	SPRING, COMPRESSION RESORTE DE COMPRESION	1	1	
4	4GL-18120-01	SHIFT LEVER ASSY PALANCA DE SELECTOR COMPLETO	1	1	
5	4ST-18531-00	BAR, SHIFT FORK GUIDE 1 BARRA GUIA HORQ. CAMBIO.1	1	1	
6	4ST-18511-00	FORK, SHIFT 1 HORQUILLA DEL CAMBIO 1	1	1	
7	4ST-18512-00	FORK, SHIFT 2 HORQUILLA DEL CAMBIO 2	1	1	
8	99009-10400	CIRCLIP PRESILLA REDONDA	2	2	
-----					
-----					
-----					
-----					
-----					
-----					
-----					
-----					
-----					
-----					

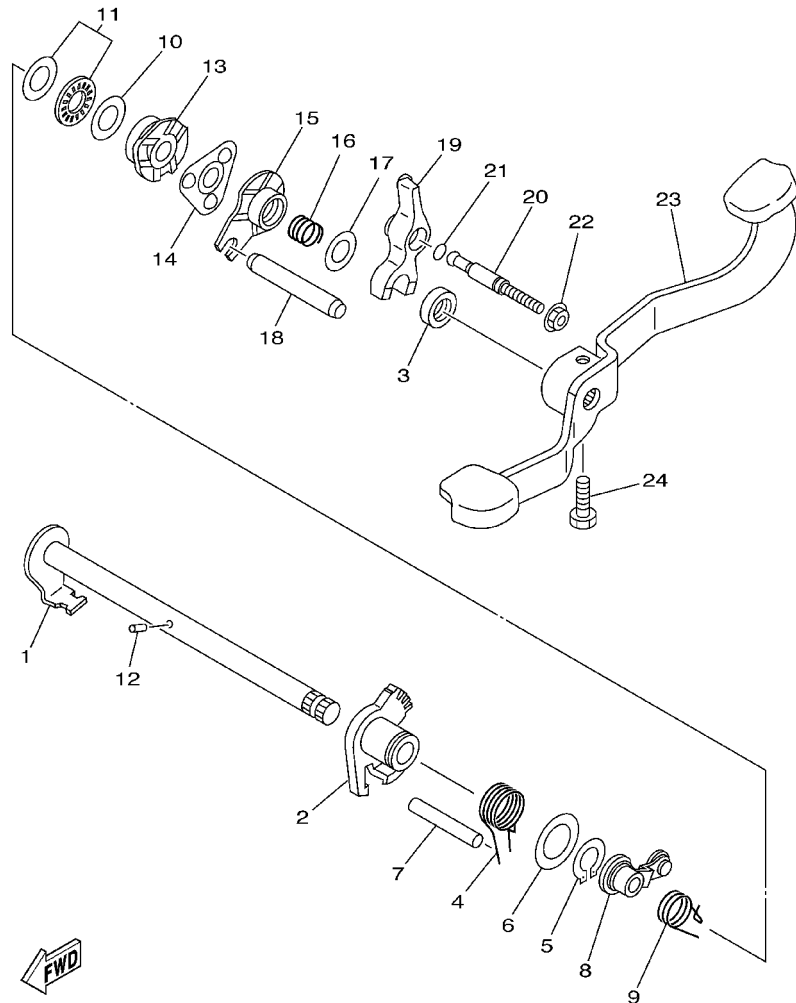

5AM3200-9160

FIG. 16 SHIFT SHAFT

EJE DE CAMBIO. PEDAL

REF. NO.	PART NO. CODIGO NO.	DESCRIPTION DESCRIPTION	5AM3	5AM4	REMARKS OBSERVACION
1	4ST-18101-01	SHIFT SHAFT ASSY EJE SELECTOR COMPLETO	1	1	
2	4GL-18152-00	LEVER, SHIFT 4 PALANCA DE CAMBIO 4	1	1	
3	93102-12891	OIL SEAL RETEN DE ACEITE	1	1	
4	90508-295A0	SPRING, TORSION RESORTE DE TORSION	1	1	
5	99009-20400	CIRCLIP PRESILLA REDONDA	1	1	
6	90201-20276	WASHER, PLATE (T=1.0) ARANDELA, PLACA (T=1.0)	1	1	
7	93608-50149	PIN, DOWEL PASADOR DE CLAVIJA	1	1	
8	4GL-18140-00	STOPPER LEVER ASSY PALANCA DE TOPE COMPLETA	1	1	
9	90508-265A1	SPRING, TORSION RESORTE DE TORSION	1	1	
10	90201-126L0	WASHER, PLATE ARANDELA PLANA	1	1	
11	93340-21209	BEARING COJINETES CON RODAMIENTOS	1	1	
12	93604-10011	PIN, DOWEL PASADOR DE CLAVIJA	1	1	
13	4GL-18179-00	GUIDE GUIA	1	1	
14	4GL-18181-00	HOLDER, PAWL SOSTEN DE SUJETADOR	1	1	
15	4GL-18172-00	GUIDE, SHIFT GUIA DE CAMBIO	1	1	
16	90501-125E9	SPRING, COMPRESSION RESORTE DE COMPRESION	1	1	
17	90201-126A7	WASHER, PLATE ARANDELA PLANA	1	1	
18	55K-18531-00	BAR, SHIFT FORK GUIDE 1 BARRA GUIA HORQ. CAMBIO 1	1	1	
19	4GL-1817A-00	ARM, SHIFT 3 BRAZO, DE CAMBIO 3	1	1	
20	4GL-18186-00	SCREW, ADJUSTING TORNILLO DE AJUSTE	1	1	
21	93210-068F7	O-RING JUNTA TORICA	1	1	
22	95707-06500	NUT, FLANGE TUERCA DE BRIDA	1	1	
23	4ST-E8111-00-93	PEDAL, SHIFT PEDAL DEL CAMBIO	1	1	CHROME PLATED
24	97017-08020	BOLT PERNO	1	1	

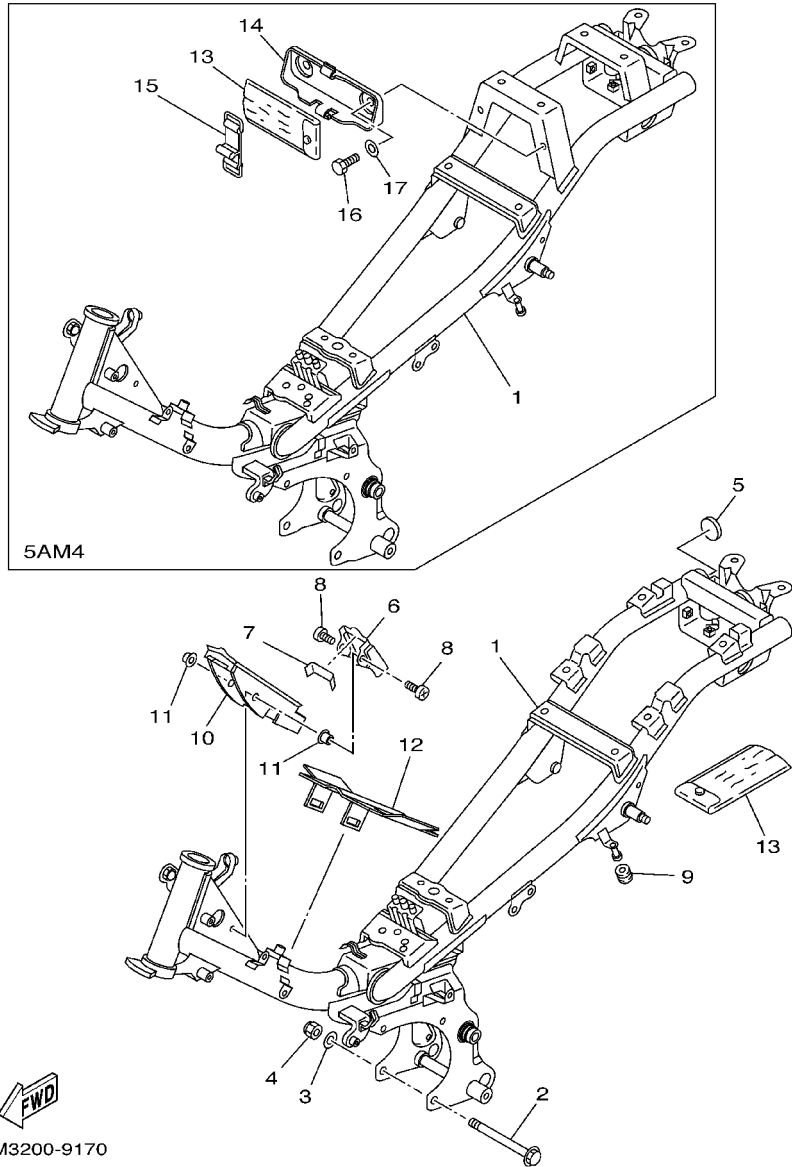

FIG. 17 FRAME

CUADRO

REF. NO.	PART NO. CODIGO NO.	DESCRIPTION DESCRIPTION	5AM3	5AM4	REMARKS OBSERVACION
1	4ST-F1110-00-33	FRAME COMP. ARMAZON COMPLETO	1		YAMAHA BLACK
	5AM-F1110-00-33	FRAME COMP. ARMAZON COMPLETO		1	YAMAHA BLACK
2	90105-08024	BOLT, FLANGE TORNILLO	3	3	
3	90201-086P8	WASHER, PLATE ARANDELA PLANA	3	3	
4	95607-08200	NUT, SELF-LOCKING TUERCA DE AUTO-CIERRE	3	3	
5	4ST-F139R-00	COVER 2 CUBIERTA 2	2	2	
6	4ST-F117F-00	COVER CUBIERTA	1	1	
7	4ST-F139X-00	DAMPER AMORTIGUADOR	1	1	
8	90149-06184	SCREW, BINDING TORNILLO DE LIGAR	2	2	
9	90480-10334	GROMMET TAPON	2	2	
10	4ST-F117G-00	PROTECTOR PROTECTOR	1	1	
11	90387-06681	COLLAR COLLAR	2	2	
12	4ST-F117N-00	COVER 3 CUBIERTA 3	1	1	
13	4ST-F8100-00	TOOL KIT JUEGO DE HERRAMIENTAS	1	1	
14	29N-21653-00	BOX CAJA		1	
15	5H9-21376-00	BAND, TOOL BANDA DE HERRAMIENTA		1	
16	97007-06016	BOLT PERNO		2	
17	90201-06380	WASHER, PLATE ARANDELA PLANA		2	

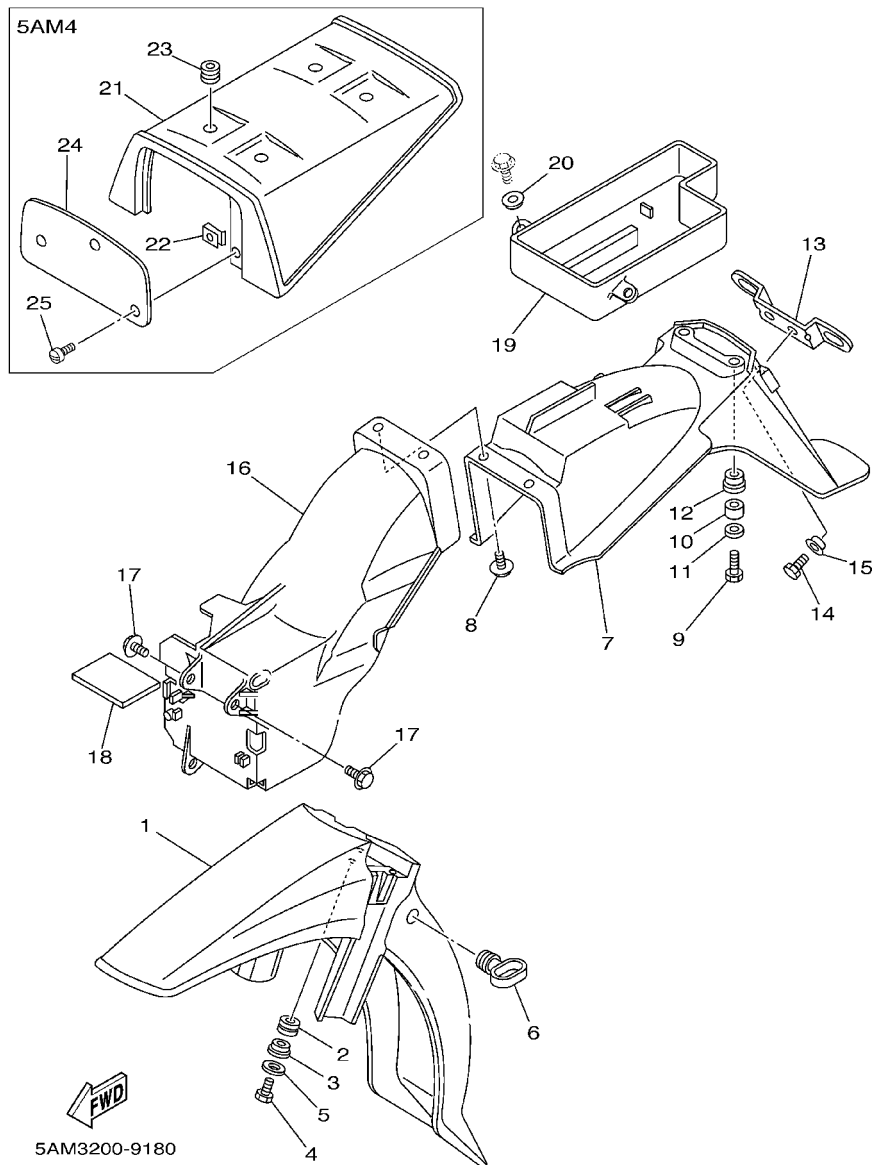

FIG. 18 FENDER

GUARDABARRO

REF. NO.	PART NO. CODIGO NO.	DESCRIPTION DESCRIPTION	5AM3	5AM4	REMARKS OBSERVACION
1	3XA-F1511-00-33	FENDER, FRONT GUARDABARRO DELANTERO	1	1	UR YB
	3XA-F1511-00-MW	FENDER, FRONT GUARDABARRO DELANTERO	1	1	UR BIB
	3XA-F1511-00-21	FENDER, FRONT GUARDABARRO DELANTERO	1	1	UR VRC1
2	90480-12314	GROMMET TAPON	3	3	
3	90387-068J7	COLLAR COLLAR	3	3	
4	97017-06020	BOLT PERNO	3	3	
5	92907-06600	WASHER, PLATE ARANDELA	3	3	
6	4ST-F1518-00	HOLDER, CABLE SOPORTE DE CABLE	1	1	
7	3XA-F1611-00	FENDER, REAR GUARDABARRO TRASERO	1	1	
8	90119-06044	BOLT, WITH WASHER TORNILLO CON ARANDELA	2	2	
9	97017-06020	BOLT PERNO	2	2	
10	90387-060G7	COLLAR COLLAR	2	2	
11	90201-06557	WASHER, PLATE ARANDELA PLANA	2	2	
12	90480-13398	GROMMET TAPON	2	2	
13	3AY-F1685-00-33	BRACKET, LICENSE SOPORTE DE LICENCIA	1	1	YAMAHA BLACK
14	97017-06020	BOLT PERNO	2	2	
15	90387-06681	COLLAR COLLAR	2	2	
16	4ST-F1629-00	GUARD, MUD GUARDABARRO INFERIOR	1	1	
17	90119-06044	BOLT, WITH WASHER TORNILLO CON ARANDELA	3	3	
18	4ST-F1638-00	DAMPER 1 AMORTIGUADOR 1	1	1	
19	4ST-F160E-00	BOX CAJA	1		
20	90387-06681	COLLAR COLLAR	2		
21	5AM-F4846-00	COVER 2 CUBIERTA 2		1	
22	90183-06059	NUT, SPRING TUERCA DE RESORTE		1	
23	90480-22800	GROMMET TAPON		4	
24	5AM-F4796-00	COVER CUBIERTA		1	
25	90146-06011	SCREW, OVAL FILLISTER TORNILLO CABEZA OVAL RANURADA		1	

FIG. 19 SIDE COVER

CUBIERTA LATERAL

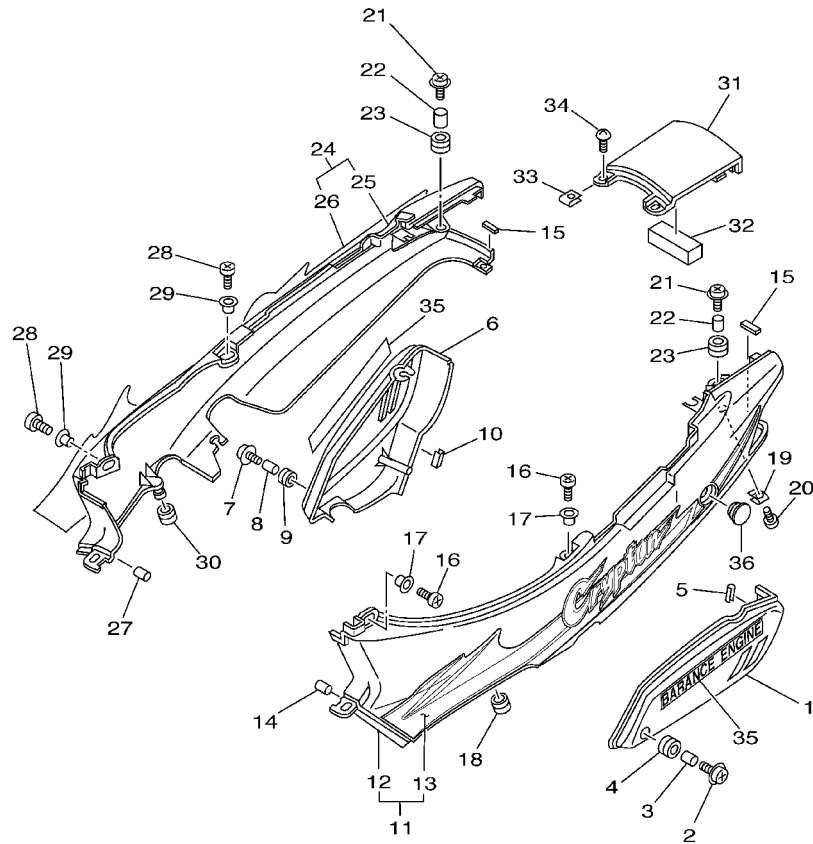

5AM3200-9190

REF. NO.	PART NO. CODIGO NO.	DESCRIPTION DESCRIPTION	5AM3	5AM4	REMARKS OBSERVACION
1	3XA-F1711-00-33	COVER, SIDE 1 JUEGO DE GRAFICOS 1	1	1	UR YB
	3XA-F1711-00-MW	COVER, SIDE 1 JUEGO DE GRAFICOS 1	1	1	UR BIB
	3XA-F1711-00-21	COVER, SIDE 1 JUEGO DE GRAFICOS 1	1	1	UR VRC1
2	90159-06067	SCREW, WITH WASHER TORNILLO CON VALONA	1	1	
3	90387-060G7	COLLAR COLLAR	1	1	
4	90480-13398	GROMMET TAPON	1	1	
5	2JG-2171L-00	MOLE, SIDE COVER 1 MUELLE, CUBIERTA LATERAL 1	1	1	
6	3XA-F1721-00-33	COVER, SIDE 2 JUEGO DE GRAFICOS 2	1	1	UR YB
	3XA-F1721-00-MW	COVER, SIDE 2 JUEGO DE GRAFICOS 2	1	1	UR BIB
	3XA-F1721-00-21	COVER, SIDE 2 JUEGO DE GRAFICOS 2	1	1	UR VRC1
7	90159-06067	SCREW, WITH WASHER TORNILLO CON VALONA	1	1	
8	90387-060G7	COLLAR COLLAR	1	1	
9	90480-13398	GROMMET TAPON	1	1	
10	2JG-2171M-10	MOLE, SIDE COVER 2 MUELLE, CUBIERTA LATERAL 2	1	1	
11	5AM-F1730-00-33	SIDE COVER ASSY 3 CUBIERTA LATERAL COMPLETA 3	1		UR YB GREEN GRP
	5AM-F1730-10-33	SIDE COVER ASSY 3 CUBIERTA LATERAL COMPLETA 3	1	1	UR YB WHITE GRP
	5AM-F1730-20-MW	SIDE COVER ASSY 3 CUBIERTA LATERAL COMPLETA 3	1	1	UR BIB
	5AM-F1730-30-21	SIDE COVER ASSY 3 CUBIERTA LATERAL COMPLETA 3	1	1	UR VRC1
12	3XA-F1731-00-33	.COVER, SIDE 3 .TAPA LATERAL 3	1	1	UR YB
	3XA-F1731-00-MW	.COVER, SIDE 3 .TAPA LATERAL 3	1	1	UR BIB
	3XA-F1731-00-21	.COVER, SIDE 3 .TAPA LATERAL 3	1	1	UR VRC1
13	5AM-F173E-00	.GRAPHIC 1 .GRAFICO 1	1		UR FOR YB GREEN GRP
	5AM-F173E-10	.GRAPHIC 1 .GRAFICO 1	1	1	UR FOR YB WHITE GRP
	5AM-F173E-20	.GRAPHIC 1 .GRAFICO 1	1	1	UR FOR BIB
	5AM-F173E-30	.GRAPHIC 1 .GRAFICO 1	1	1	UR FOR VRC1
14	3XA-F622F-00	DAMPÉR, LOCATING 1 AMORTIGUADOR, DE UBICACION 1	1	1	
15	3XA-F174X-01	DAMPER AMORTIGUADOR	2	2	

FIG. 19 SIDE COVER

CUBIERTA LATERAL

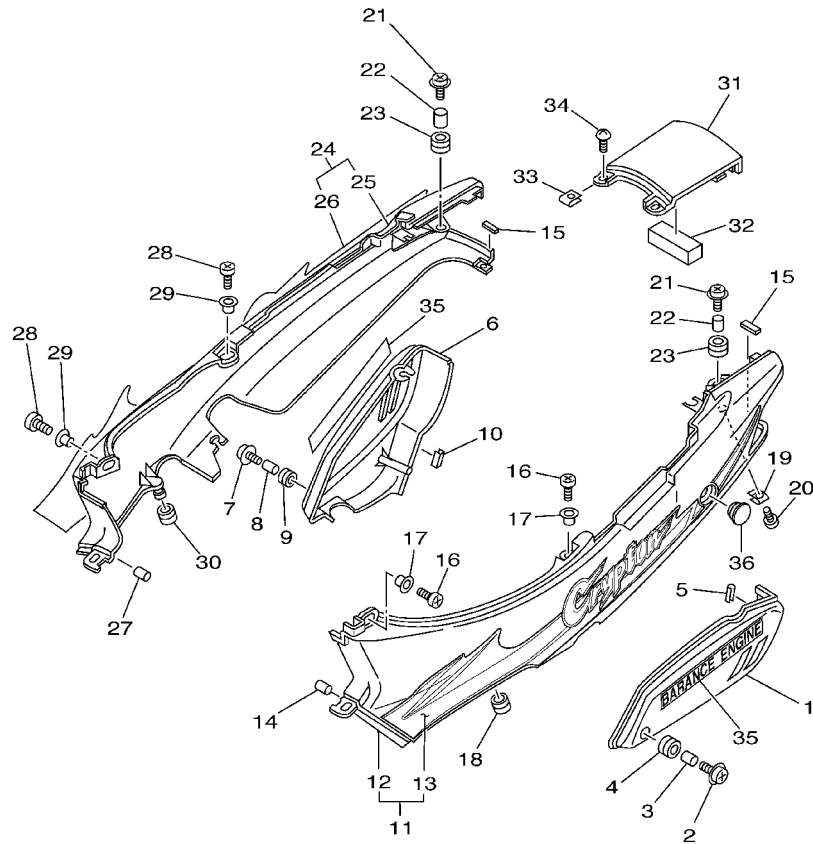

FWD  
5AM3200-9190

REF. NO.	PART NO. CODIGO NO.	DESCRIPTION DESCRIPTION	5AM3	5AM4	REMARKS OBSERVACION
16	98507-06016	SCREW TORNILLO DE CABEZA CON PLANA	2	2	
17	90387-06681	COLLAR COLLAR	2	2	
18	90480-10334	GROMMET TAPON	1	1	
19	90183-05042	NUT, SPRING TUERCA DE RESORTE	1	1	
20	97707-50012	SCREW, TAPPING TORNILLO ROSCA HEMBRA	1	1	
21	90159-06085	SCREW, WITH WASHER TORNILLO CON VALONA	2	2	
22	90387-060G7	COLLAR COLLAR	2	2	
23	90480-13398	GROMMET TAPON	2	2	
24	5AM-F1740-00-33	SIDE COVER ASSY 4 CUBIERTA LAT. COMPLETA 4	1		UR YB GREEN GRP
	5AM-F1740-10-33	SIDE COVER ASSY 4 CUBIERTA LAT. COMPLETA 4	1	1	UR YB WHITE GRP
	5AM-F1740-20-MW	SIDE COVER ASSY 4 CUBIERTA LAT. COMPLETA 4	1	1	UR BIB
	5AM-F1740-30-21	SIDE COVER ASSY 4 CUBIERTA LAT. COMPLETA 4	1	1	UR VRC1
25	3XA-F1741-00-33	.COVER, SIDE 4 .CUBIERTA LATERAL 4	1	1	UR YB
	3XA-F1741-00-MW	.COVER, SIDE 4 .CUBIERTA LATERAL 4	1	1	UR BIB
	3XA-F1741-00-21	.COVER, SIDE 4 .CUBIERTA LATERAL 4	1	1	UR VRC1
26	5AM-F173F-00	.GRAPHIC 2 .GRAFICO 2	1		UR FOR YB GREEN GRP
	5AM-F173F-10	.GRAPHIC 2 .GRAFICO 2	1	1	UR FOR YB WHITE GRP
	5AM-F173F-20	.GRAPHIC 2 .GRAFICO 2	1	1	UR FOR BIB
	5AM-F173F-30	.GRAPHIC 2 .GRAFICO 2	1	1	UR FOR VRC1
27	3XA-F622F-00	DAMPER, LOCATING 1 AMORTIGUADOR, DE UBICACION 1	1	1	
28	98507-06016	SCREW TORNILLO DE CABEZA CON PLANA	2	2	
29	90387-06681	COLLAR COLLAR	2	2	
30	90480-10334	GROMMET TAPON	1	1	
31	3XA-F171E-00-33	COVER, SIDE 5 CUBIERTA LATERAL 5	1	1	UR YB
	3XA-F171E-00-MW	COVER, SIDE 5 CUBIERTA LATERAL 5	1	1	UR BIB
	3XA-F171E-00-21	COVER, SIDE 5 CUBIERTA LATERAL 5	1	1	UR VRC1
32	3XA-F174Y-00	DAMPER AMORTIGUADOR	1	1	



FIG. 20 REAR ARM. SUSPENSION

BRAZO TRASERO. SUSPENSION

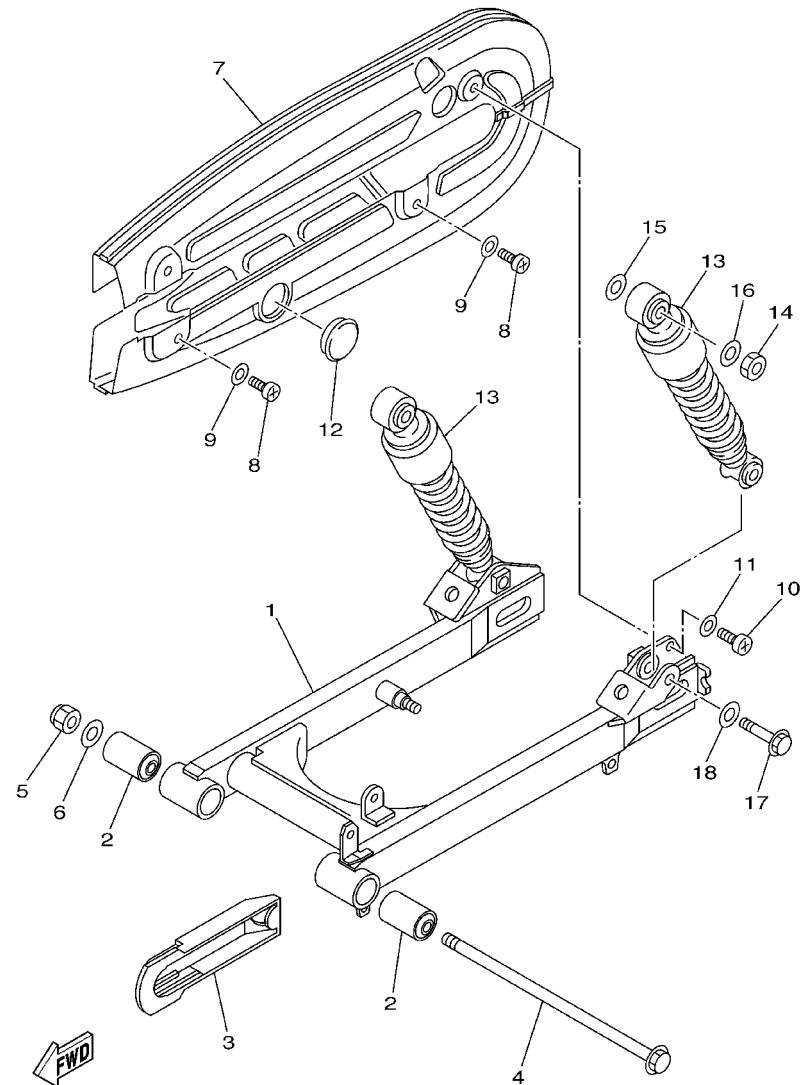

5AM3200-9200

REF. NO.	PART NO. CODIGO NO.	DESCRIPTION DESCRIPTION	5AM3	5AM4	REMARKS OBSERVACION
1	4ST-F2110-00-WN	REAR ARM COMP. BRAZO TRASERO COMPLETO	1	1	CIRCUIT SILVER
2	307-22123-00	BUSH 1 BUJE 1	2	2	
3	4ST-F2151-00	SEAL, GUARD SELLO DE GUARDA	1	1	
4	3AY-F2141-01	SHAFT, PIVOT EJE DEL BARRULANTE	1	1	
5	90185-12046	NUT, SELF-LOCKING TUERCA AUTOBLOCANTE	1	1	
6	92907-12600	WASHER ARANDELA	1	1	
7	4ST-F2310-00-33	CHAIN CASE ASSY CAJA DE CADENA COMPLETA	1		YAMAMA BLACK
	4ST-F2310-10-WN	CHAIN CASE ASSY CAJA DE CADENA COMPLETA	1	1	CIRCUIT SILVER
8	98507-05010	SCREW TORNILLO DE CABEZA CON PLANA	3	3	
9	92907-05600	WASHER, PLATE ARANDELA	3	3	
10	98504-06010	SCREW, PAN HEAD TORNILLO DE CABEZA CON PLANA	1	1	
11	92990-06600	WASHER, PLATE ARANDELA PLANA	1	1	
12	4ST-F2315-00	CAP TAPA	1	1	
13	4ST-F2210-00	SHOCK ABSORBER ASSY, REAR AMORTIGUADOR TRASERO COMPLETO	2	2	
14	95307-10600	NUT TUERCA	2	2	
15	90201-126A7	WASHER, PLATE ARANDELA PLANA	2	2	
16	90201-106F2	WASHER, PLATE ARANDELA PLANA	2	2	
17	90105-10778	BOLT, FLANGE TORNILLO	2	2	
18	92907-10600	WASHER, PLATE ARANDELA	2	2	

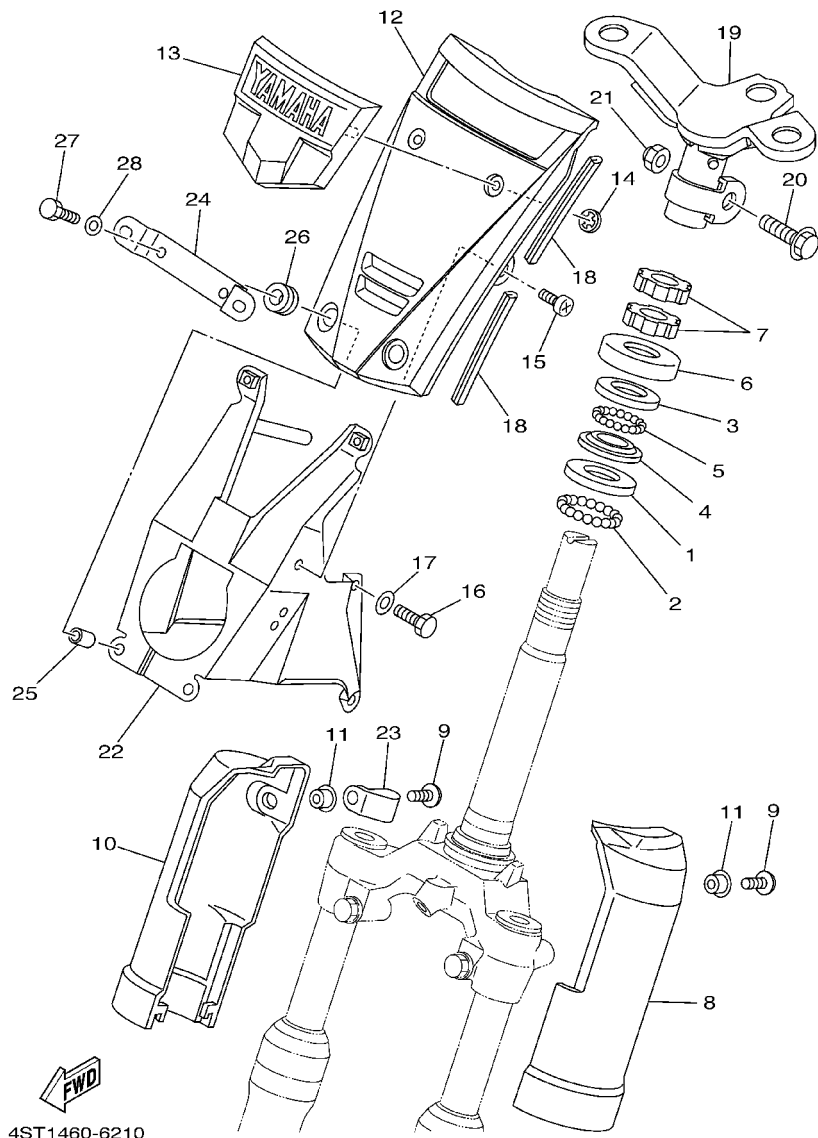

4ST1460-6210

FIG. 21 STEERING

DIRECCION

REF. NO.	PART NO. CODIGO NO.	DESCRIPTION DESCRIPTION	5AM3	5AM4	REMARKS OBSERVACION
1	156-23412-00	RACE, BALL 2 PISTA DE BOLAS 2	1	1	
2	93501-04011	BALL ESFERA	19	19	
3	22F-23412-01	RACE, BALL 2 PISTA DE BOLAS 2	1	1	
4	22F-23411-01	RACE, BALL 1 PISTA DE BOLAS 1	1	1	
5	93503-16003	BALL ESFERA	22	22	
6	3AY-F3416-00-91	COVER, BALL RACE 2 CUBIERTA DE BASE DE BOLA 2	1	1	WHITE CHROME
7	90179-25033	NUT TUERCA	2	2	
8	3XA-F3122-00-33	COVER, OUTER 1 CUBIERTA EXTERIOR 1	1	1	UR YB
	3XA-F3122-00-MW	COVER, OUTER 1 CUBIERTA EXTERIOR 1	1	1	UR BIB
	3XA-F3122-00-21	COVER, OUTER 1 CUBIERTA EXTERIOR 1	1	1	UR VRC1
9	98507-06016	SCREW TORNILLO DE CABEZA CON PLANA	2	2	
10	3XA-F3132-00-33	COVER, OUTER 2 CUBIERTA EXTERIOR 2	1	1	UR YB
	3XA-F3132-00-MW	COVER, OUTER 2 CUBIERTA EXTERIOR 2	1	1	UR BIB
	3XA-F3132-00-21	COVER, OUTER 2 CUBIERTA EXTERIOR 2	1	1	UR VRC1
11	90387-06681	COLLAR COLLAR	2	2	
12	4ST-F3391-00-33	PANEL, FRONT PANEL DELANTERO	1	1	UR YB
	4ST-F3391-00-MW	PANEL, FRONT PANEL DELANTERO	1	1	UR BIB
	4ST-F3391-00-21	PANEL, FRONT PANEL DELANTERO	1	1	UR VRC1
13	4ST-23108-00	EMBLEM EMBLEMA	1	1	
14	90183-04005	NUT, SPRING TUERCA DE RESORTE	2	2	
15	98907-05010	SCREW, BIND TORNILLO DE LIGAR	2	2	
16	97027-06012	BOLT PERNO	4	4	
17	92907-06600	WASHER, PLATE ARANDELA	4	4	
18	56J-23398-00	MOLD, FRONT MOLDURA DELANTERA	4	4	
19	4ST-F3461-00-92	BRACKET, HANDLE SOPORTE DE MANUBRIO	1	1	YELLOW CHROME
20	90105-10036	BOLT, FLANGE TORNILLO	1	1	
21	90185-10154	NUT, SELF-LOCKING TUERCA AUTOBLOCANTE	1	1	

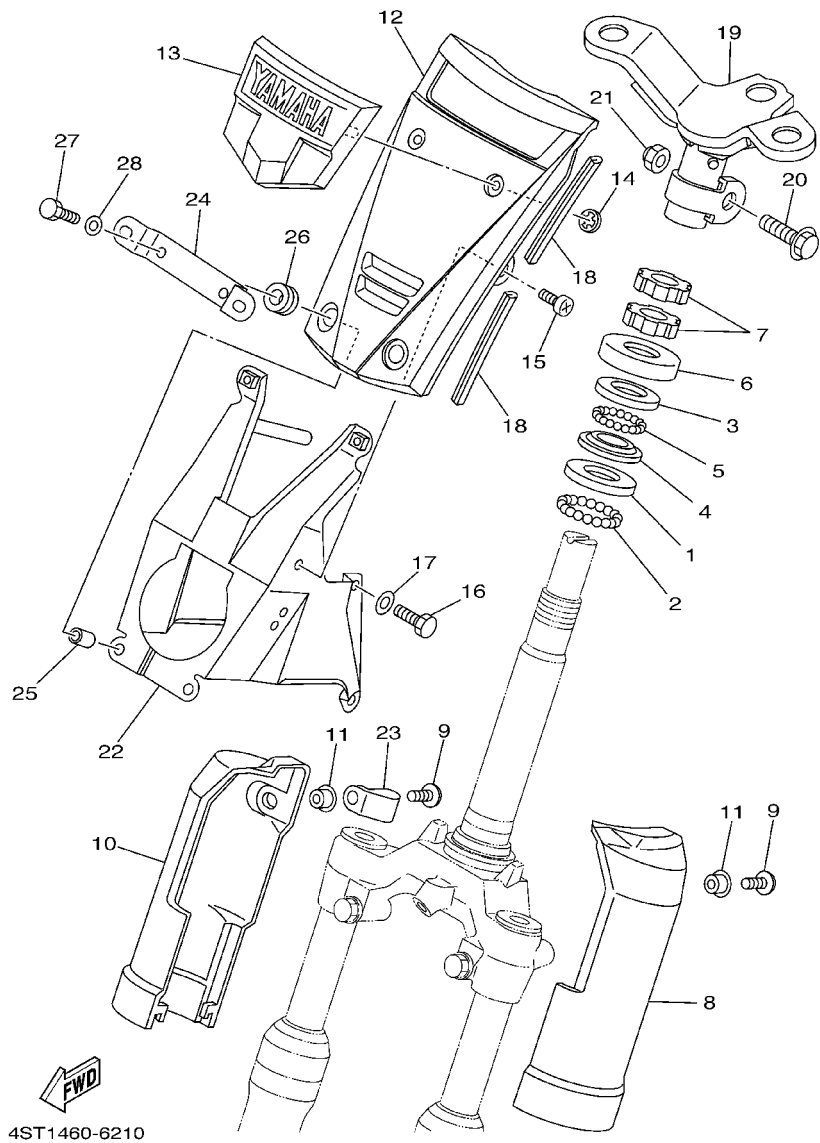

FIG. 21 STEERING

DIRECCION

REF. NO.	PART NO. CODIGO NO.	DESCRIPTION DESCRIPTION	5AM3	5AM4	REMARKS OBSERVACION
22	4ST-F331A-00-33	STAY APOYO	1	1	YAMAHA BLACK
23	4NS-F5886-00-90	HOLDER, BRAKE HOSE SOPORTE DE MANGUERA FRENO	1	1	BLACK CHROME
24	3AY-H454E-00-91	BRACKET, NUMBER PLATE SOPORTE PLACA DE LICENCIA	1	1	WHITE CHROME
25	3XA-F3113-00	COLLAR COLLAR	2	2	
26	90480-15397	GROMMET TAPON	2	2	
27	97017-06040	BOLT PERNO	2	2	
28	92907-06600	WASHER, PLATE ARANDELA	2	2	

FIG. 22 FRONT FORK

HORQUILLA DELANTERA

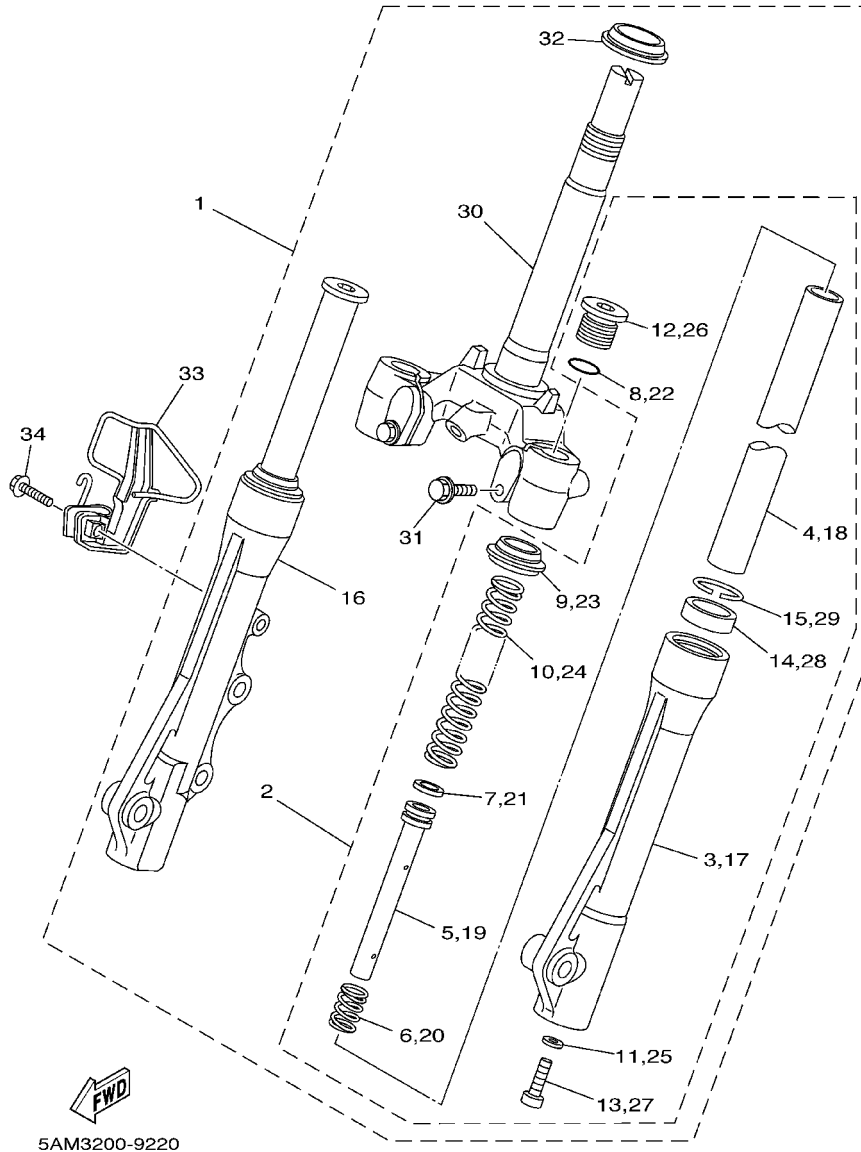

5AM3200-9220

REF. NO.	PART NO. CODIGO NO.	DESCRIPTION DESCRIPTION	5AM3	5AM4	REMARKS OBSERVACION
1	5AM-F3100-00	FRONT FORK ASSY HORQUILLA DELANTERA COMPLETA	1		UR YAMAHA BLACK
	5AM-F3100-10	FRONT FORK ASSY HORQUILLA DELANTERA COMPLETA	1	1	UR CIRCUIT SILVER
2	5AM-F3102-00	.FRONT FORK ASSY (L.H) .HORQUILLA DELANTERA COMPL.(MI)	1		UR YAMAHA BLACK
	5AM-F3102-10	.FRONT FORK ASSY (L.H) .HORQUILLA DELANTERA COMPL.(MI)	1	1	UR CIRCUIT SILVER
3	4NS-F3126-00-33	..TUBE, OUTER (LEFT) ..TUBO EXTERIOR (MI)	1		UR YAMAHA BLACK
	4NS-F3126-10-WN	..TUBE, OUTER (LEFT) ..TUBO EXTERIOR (MI)	1	1	UR CIRCUIT SILVER
4	2JG-F3110-00	..INNER TUBE COMP.1 ..TUBO INTERIOR COMPLETO 1	1	1	
5	3SB-F3170-00	..CYLINDER COMP., FRONT FORK ..CILINDRO COMPL DE HORQ DELA	1	1	
6	2JG-F3152-00	..SPRING, SUB ..RESORTE DE SUBENSAMBLE	1	1	
7	2JG-F3157-00	..RING, PISTON ..ANILLO DEL PISTON	1	1	
8	2JG-F3147-00	..O-RING ..ARO	1	1	
9	2JG-F3144-00	..SEAL, DUST ..GUARDAPOLVO	1	1	
10	4ST-F3141-00	..SPRING, FRONT FORK ..RESORTE HORQUILLA DELANT.	1	1	
11	509-F3158-L0	..GASKET ..EMPAQUE	1	1	
12	2JG-F3111-00	..BOLT, CAP ..TAPON	1	1	
13	278-F3181-50	..BOLT, HEXAGON SOCKET HEAD ..TORNILLO CABEZAHEXAGONAL	1	1	
14	2JG-F3145-00	..OIL SEAL ..RETEN DE ACEITE	1	1	
15	1T8-F3156-00	..CLIP, OIL SEAL ..PRESILLA DEL RETEN DE ACEITE	1	1	
16	5AM-F3103-00	.FRONT FORK ASSY (R.H) .HORQUILLA DELANTERA COMPL.(MD)	1		UR YAMAHA BLACK
	5AM-F3103-10	.FRONT FORK ASSY (R.H) .HORQUILLA DELANTERA COMPL.(MD)	1	1	UR CIRCUIT SILVER
17	4US-F3136-00	..TUBE, OUTER (RIGHT) ..TUBO EXTERIOR (DER.)	1		UR YAMAHA BLACK
	4US-F3136-10-WN	..TUBE, OUTER (RIGHT) ..TUBO EXTERIOR (DER.)	1	1	UR CIRCUIT SILVER
18	2JG-F3110-00	..INNER TUBE COMP.1 ..TUBO INTERIOR COMPLETO 1	1	1	
19	3SB-F3170-00	..CYLINDER COMP., FRONT FORK ..CILINDRO COMPL DE HORQ DELA	1	1	
20	2JG-F3152-00	..SPRING, SUB ..RESORTE DE SUBENSAMBLE	1	1	
21	2JG-F3157-00	..RING, PISTON ..ANILLO DEL PISTON	1	1	
22	2JG-F3147-00	..O-RING ..ARO	1	1	

FIG. 22 FRONT FORK

HORQUILLA DELANTERA

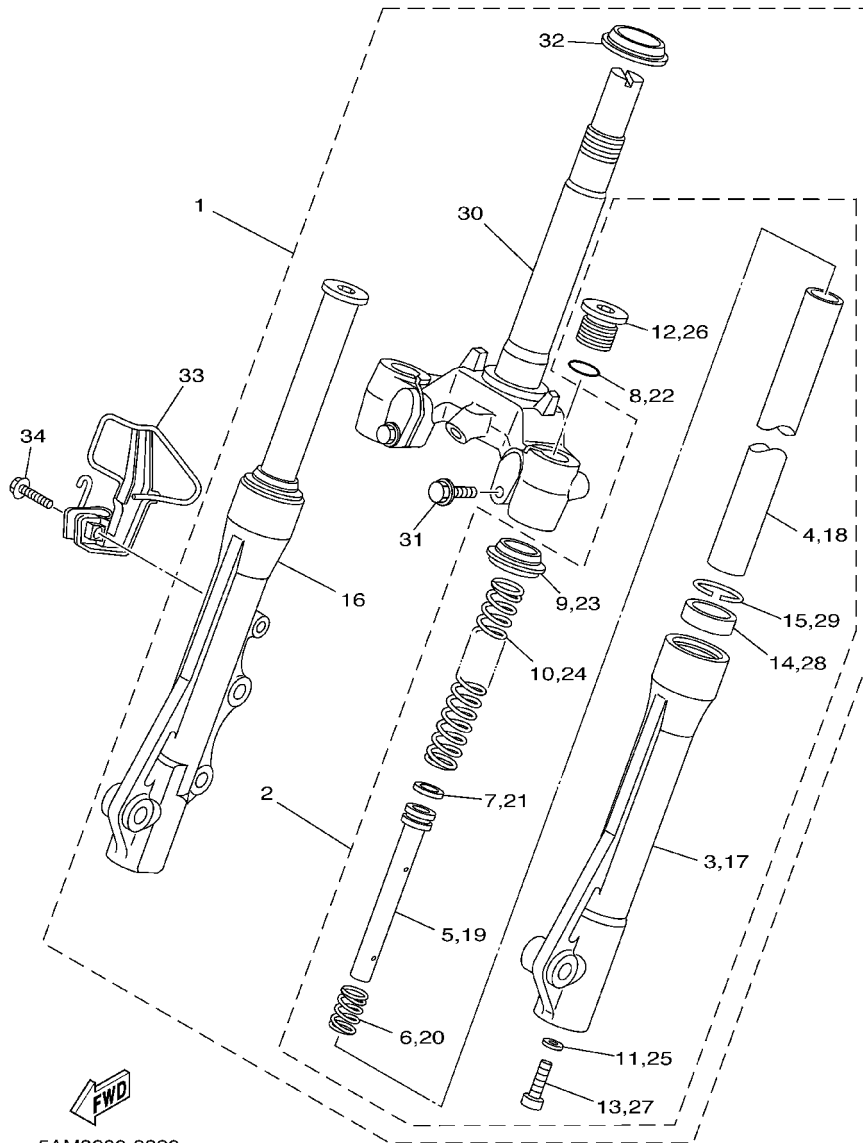

5AM3200-9220

REF. NO.	PART NO. CODIGO NO.	DESCRIPTION DESCRIPTION	5AM3	5AM4	REMARKS OBSERVACION
23	2JG-F3144-00	..SEAL, DUST ..GUARDAPOLVO	1	1	
24	4ST-F3141-00	..SPRING, FRONT FORK ..RESORTE HORQUILLA DELANT.	1	1	
25	509-F3158-L0	..GASKET ..EMPAQUE	1	1	
26	2JG-F3111-00	..BOLT, CAP ..TAPON	1	1	
27	278-F3181-50	..BOLT, HEXAGON SOCKET HEAD ..TORNILLO CABEZAHEXAGONAL	1	1	
28	2JG-F3145-00	..OIL SEAL ..RETEN DE ACEITE	1	1	
29	1T8-F3156-00	..CLIP, OIL SEAL ..PRESILLA DEL RETEN DE ACEITE	1	1	
30	3YR-F3340-00	..UNDER BRACKET COMP. ..PLATINA INFERIOR COMPLETA	1	1	
31	3YR-F3346-00	..BOLT 1 ..PERNO 1	2	2	
32	156-23411-00	..RACE, BALL 1 ..PISTA DE BOLAS 1	1	1	
33	4NS-F331E-01	..GUIDE, CABLE ..GUIA DE CABLE	1	1	
34	95027-06025	..BOLT, FLANGE ..PERNO, DE BRIDA	1	1	

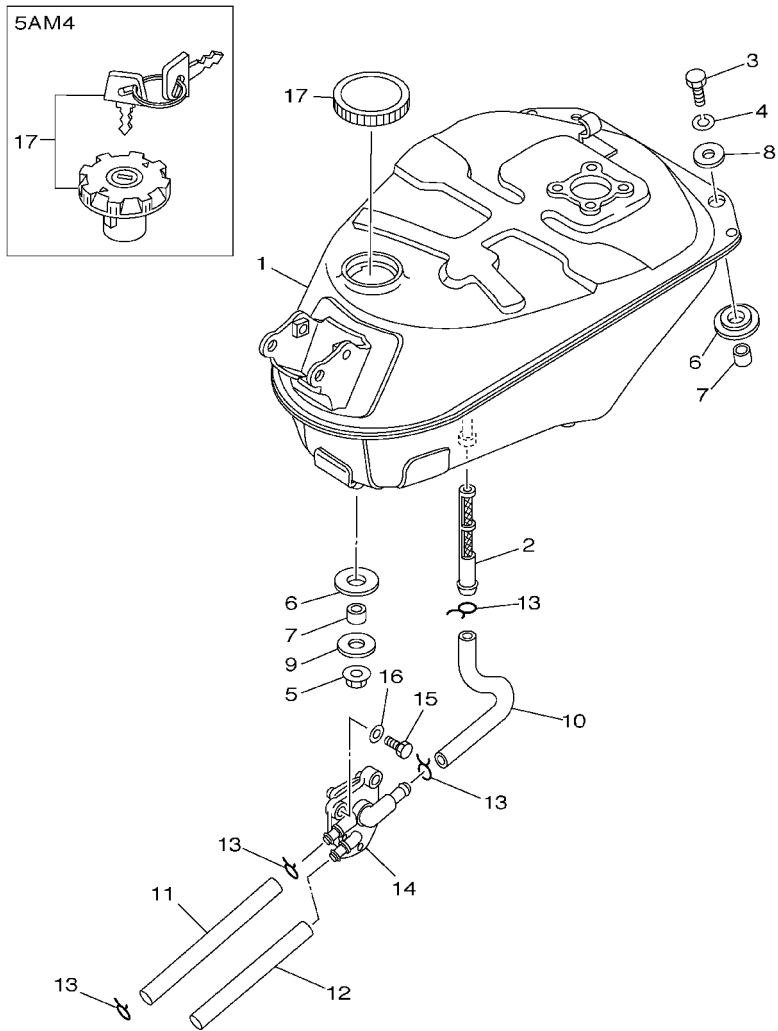

5AM3200-9230

FIG. 23 FUEL TANK

DEPOSITO DE COMBUSTIBLE

REF. NO.	PART NO. CODIGO NO.	DESCRIPTION DESCRIPTION	5AM3	5AM4	REMARKS OBSERVACION
1	4ST-F4110-00-33	FUEL TANK COMP. DEPOSITO DE COMBUSTIBLE COMP.	1	1	YAMAHA BLACK
2	2JG-24514-00	NET, FILTER 1 RED DE FILTRO 1	1	1	
3	97017-06020	BOLT PERNO	2	2	
4	92907-06100	WASHER, SPRING ARANDELA	2	2	
5	95707-08500	NUT, FLANGE TUERCA DE BRIDA	1	1	
6	90480-18476	GROMMET TAPON	3	3	
7	90387-0801M	COLLAR COLLAR	3	3	
8	90201-064K6	WASHER, PLATE ARANDELA PLANA	2	2	
9	90201-085E6	WASHER, PLATE ARANDELA PLANA	1	1	
10	3XA-F4311-00	PIPE, FUEL 1 TUBO DE COMBUSTIBLE 1	1	1	
11	4ST-F4312-00	PIPE 2 TUBO 2	1	1	
12	4ST-F4313-00	PIPE 3 TUBO 3	1	1	
13	90467-10008	CLIP PRESILLA	4	4	
14	2JG-24500-01	FUEL COCK ASSY 1 GRIFO DE COMBUSTIBLE 1	1	1	
15	97027-06012	BOLT PERNO	2	2	
16	92907-06600	WASHER, PLATE ARANDELA	2	2	
17	23T-F4610-V0	CAP ASSY TAPA COMPLETA	1		
	5AM-F461A-00	CAP ASSY (WITH KEY) CONJUNTO DEL TACOMETRO		1	

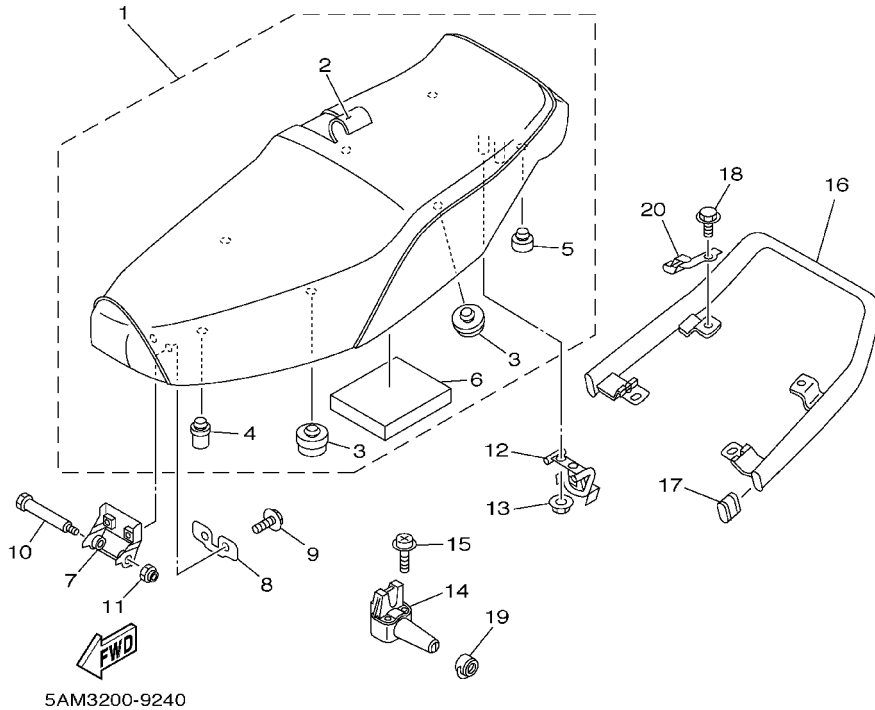
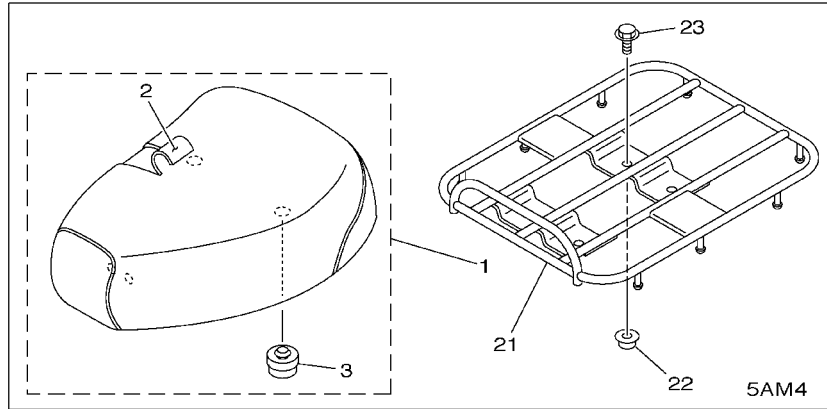

FIG. 24 SEAT

ASIENTO

REF. NO.	PART NO. CODIGO NO.	DESCRIPTION DESCRIPTION	5AM3	5AM4	REMARKS OBSERVACION
1	4ST-F4730-00	DOUBLE SEAT ASSY	1		
	5AM-F4730-00	SILLIN DOBLE COMPLETO		1	
2	4ST-F470F-00	.SEAT COVER COMP.	1		
	5AM-F470F-00	FUNDADE SILLIN		1	
3	23T-F4741-01	.PAD, SEAT	4		
	23T-F4741-01	.COJIN DE ASIENTO		2	
4	3AY-F4763-00	.PAD, SEAT 2	1		
		.COJIN DE ASIENTO 2			
5	3RS-F4724-00	.DAMPER, SEAT	2		
		.AMORTIGUADOR DE ASIENTO			
6	3XA-F472E-00	.SEAL	1		
		.SELLO			
7	3XA-F4726-00	HINGE, SEAT	1	1	
		HINGE SEAT			
8	3XA-F4744-00	PLATE, SEAT FITTING	1	1	
		PLACA ACCESORIA DE ASIENTO			
9	90119-06044	BOLT, WITH WASHER	2	2	
		TORNILLO CON ARANDELA			
10	90109-065E0	BOLT	1	1	
		PERNO			
11	95607-06100	NUT, U	1	1	
		TUERCA AUTOBLOCANTE			
12	3XA-F4728-00	BRACKET, SEAT	1		
		SOPORTE DE ASIENTO			
13	95707-06500	NUT, FLANGE	2		
		TUERCA DE BRIDA			
14	3AY-F4780-V0	SEAT LOCK ASSY	1		
		TORNILLO CONTROL DE AIRE			
15	90159-06064	SCREW, WITH WASHER	2		
		TORNILLO CON VALONA			
16	3XA-F4773-00-33	HANDLE, SEAT	1		LOW GLOSS BLACK
		MANIJA DE ASIENTO			
17	3AY-F4742-00	GROMMET	2		
		ANILLO PROTECTOR			
18	95827-06012	BOLT, FLANGE	4		
		TUERCA DE REBORDE			
19	3AY-F4796-00	COVER	1		
		CUBIERTA			
20	3XA-F1398-00	HANGER, HELMET	1		
		COLGADOR DE CASCO			
21	5AM-F4810-00-93	CARRIER ASSY		1	
		PORTADOR COMPLETO			
22	5AM-F1784-00	COLLAR		4	
		COLLAR			
23	95827-08025	BOLT, FLANGE		4	
		TUERCA DE REBORDE			

FIG. 25 FRONT WHEEL

RUEDA DELANTERA

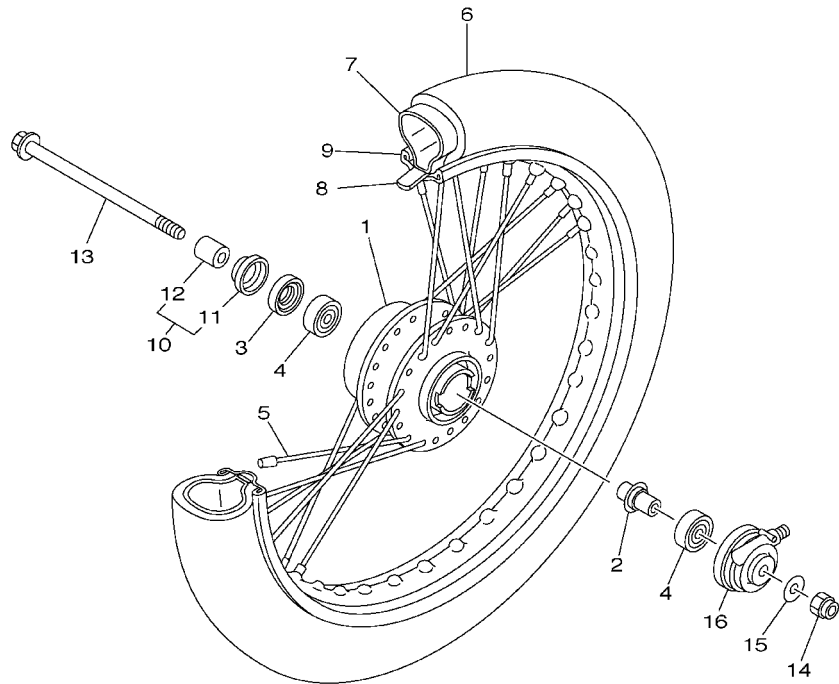

REF. NO.	PART NO. CODIGO NO.	DESCRIPTION DESCRIPTION	5AM3	5AM4	REMARKS OBSERVACION
1	4NS-F5111-00-33	HUB, FRONT MASA DELANTERA	1		UR YAMAHA BLACK
	4NS-F5111-10-WN	HUB, FRONT MASA DELANTERA	1	1	UR CIRCUIT SILVER
2	4ST-F5116-00	FLANGE, SPACER 2 BRIDA DE ESPACIADOR 2	1	1	
3	93106-20816	OIL SEAL RETEN DE ACEITE	1	1	
4	93306-300Y6	BEARING COJINETE	2	2	
5	4NS-F5104-00	SPOKE SET, FRONT JUEGO DE RAYOS DELANTERO	1	1	
6	94122-17008	TIRE (2.25-17 7F) NEUMATICO (2.25-17 7F)	1	1	INOUE
7	94222-17269	TUBE (2.25/2.50-17 TR4) TUBO (2.25/2.50-17 TR4)	1	1	INOUE
8	94332-17112	BAND,RIM (25-17) BANDA DE ARO (25-17)	1	1	INOUE
9	94414-17888-93	RIM (1.40-17) ARO (1.40-17)	1	1	CHROME PLATED
10	4ST-F5183-00	COLLAR, WHEEL COLLAR DE RUEDA	1	1	
11	4ST-F5118-00	.COVER, HUB DUST .CUBIERTA DE MASA PARA POLVO	1	1	
12	90387-10277	.COLLAR .COLLAR	1	1	
13	3AY-F5181-01-91	AXLE, WHEEL EJE DE LA RUEDA	1	1	WHITE CHROME
14	90185-10091	NUT, SELF-LOCKING TUERCA AUTOBLOCANTE	1	1	
15	90201-101J1	WASHER, PLATE ARANDELA PLANA	1	1	
16	3PP-25190-01	GEAR UNIT ASSY UNIDAD DE ENGRANAJE COMPLETA	1	1	



5AM3200-9250

FIG. 26 FRONT BRAKE CALIPER

CALIBRE FRENO DELANTERA

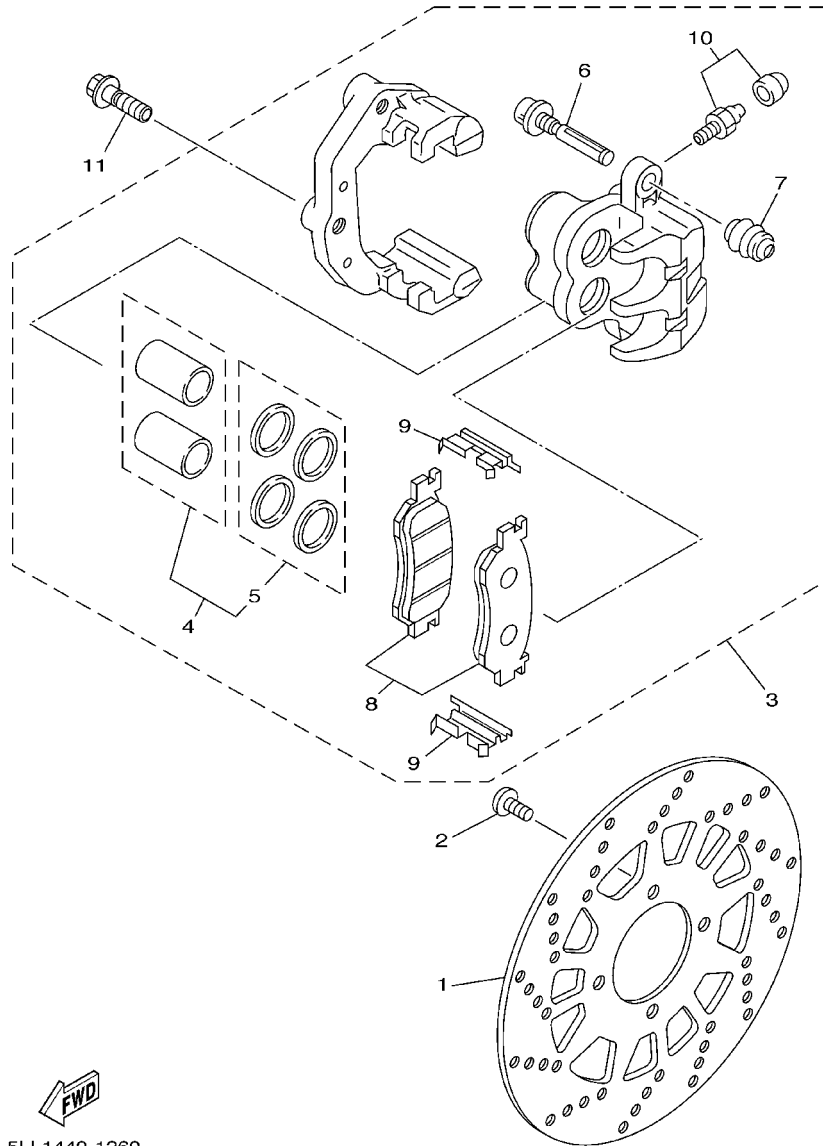

5LL1440-1260

REF. NO.	PART NO. CODIGO NO.	DESCRIPTION DESCRIPTION	5AM3	5AM4	REMARKS OBSERVACION
1	4NS-F582U-00	DISC, BRAKE (RIGHT) DISCO DE FRENO (DERECO)	1	1	
2	90109-081F0	BOLT PERNO	4	4	
3	4US-F580U-00	CALIPER ASSY (RIGHT) CALIBRE COMPLETO (DERECO)	1	1	
4	4TT-W0057-00	.PISTON ASSY, CALIPER .PISTON COMPLETO PINZA	1	1	
5	4ES-W0047-10	..CALIPER SEAL KIT ..JUEGO DE RETENES DE PINZA	1	1	
6	4TT-25914-00	.PIN, SLIDE .PASADOR	2	2	
7	4TT-25937-00	.BOOT 2 .FUNDA 2	2	2	
8	4US-W0045-00	.BRAKE PAD KIT .JUEGO DE COJIN DE FRENO	1	1	
9	4TT-25919-00	.SUPPORT, PAD .SOPORTE DE PASTILLAS	2	2	
10	51L-W0048-00	.BLEED SCREW KIT .CJTO TORNILLO DE PURGA	1	1	
11	90105-10638	BOLT, WASHER BASED TORNILLO CON ARANDELA	2	2	

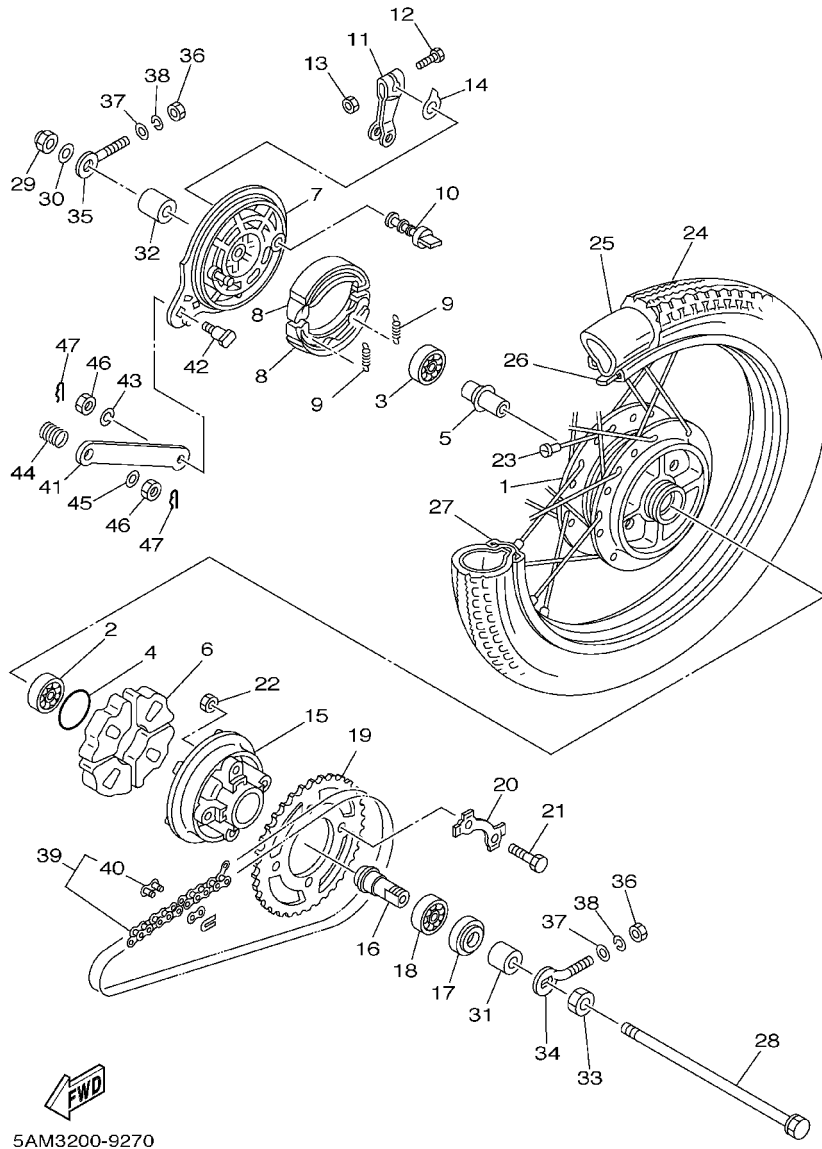

5AM3200-9270

FIG. 27 REAR WHEEL

RUEDA TRASERA

REF. NO.	PART NO. CODIGO NO.	DESCRIPTION DESCRIPTION	5AM3	5AM4	REMARKS OBSERVACION
1	23T-F5311-00-33	HUB, REAR MASA TRASERA	1		UR YAMAHA BLACK
	23T-F5311-10-WN	HUB, REAR MASA TRASERA	1	1	UR CIRCUIT SILVER
2	93306-301Y9	BEARING COJINETE	1	1	
3	93306-301Y8	BEARING COJINETE	1	1	
4	93210-41041	O-RING JUNTA TORICA	1	1	
5	4ST-F5316-00	FLANGE, SPACER 2 BRIDA DE ESPACIADOR 2	1	1	
6	23T-F5364-00	DAMPER AMORTIGUADOR	4	4	
7	23T-F5321-01-33	PLATE, BRAKE SHOE PLACA DE ZAPATA DE FRENO	1		UR YAMAHA BLACK
	23T-F5321-11-WN	PLATE, BRAKE SHOE PLACA DE ZAPATA DE FRENO	1	1	UR CIRCUIT SILVER
8	23T-F5330-00	BRAKE SHOE COMP. ZAPATA DE FRENO COMPLETA	2	2	
9	90506-18288	SPRING, TENSION RESORTE DE TENSION	2	2	
10	4GL-25351-00	CAMSHAFT ARBOL DE LEVAS	1	1	
11	3AY-F5355-00-91	LEVER, CAMSHAFT PALANCA DE ARBOL DE LEVAS	1	1	WHITE CHROME
12	90101-06278	BOLT TORNILLO	1	1	
13	95307-06600	NUT TUERCA	1	1	
14	4ST-F533A-00	PLATE, INDICATOR PLACA INDICADOR	1	1	
15	37J-F5366-01	CLUTCH, HUB EMBRAGUE DE MASA	1	1	
16	167-25387-00	AXLE, SPROCKET EJE DE CORONA	1	1	
17	93106-30817	OIL SEAL RETEN DE ACEITE	1	1	
18	93306-004Y8	BEARING COJINETE	1	1	UR
	93306-004X6	BEARING COJINETE	1	1	UR
19	4ST-F5437-00	SPROCKET, DRIVEN (37T) CORONA (37T)	1	1	
20	4ST-F5412-00	WASHER ARANDELA	2	2	
21	90101-08672	BOLT TORNILLO	4	4	
22	90179-08168	NUT TUERCA	4	4	
23	23T-F5304-01	SPOKE SET, REAR JUEGO DE RAYOS TRASEROS	1	1	
24	94125-17012	TIRE (2.50-17 4P.R.) NEUMATICO (2.50-17 4P.R.)	1	1	INOUE

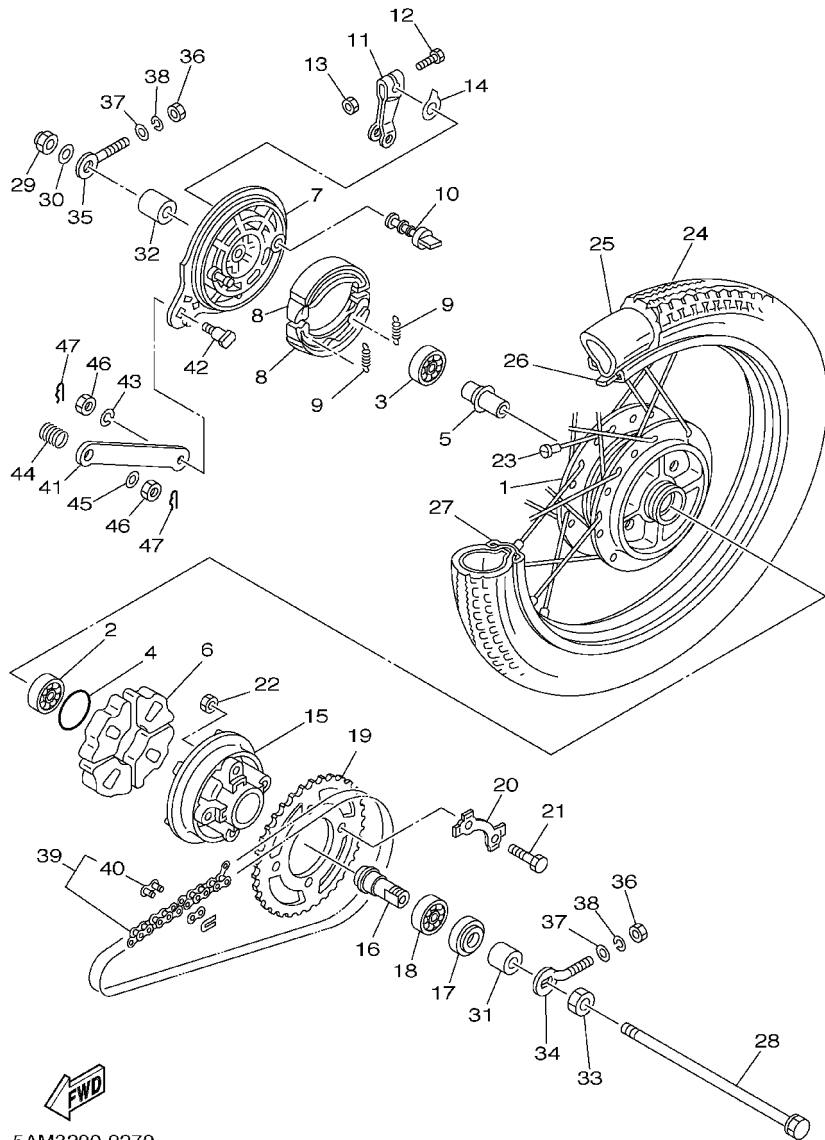

5AM3200-9270

FIG. 27 REAR WHEEL

RUEDA TRASERA

REF. NO.	PART NO. CODIGO NO.	DESCRIPTION DESCRIPTION	5AM3	5AM4	REMARKS OBSERVACION
25	94222-17269	TUBE (2.25/2.50-17 TR4) TUBO (2.25/2.50-17 TR4)	1	1	INOUE
26	94325-17004	BAND, RIM (2.50-17) BANDA DE ARO (2.50-17)	1	1	INOUE
27	94414-17849-93	RIM (1.40-17) ARO (1.40-17)	1	1	CHROME PLATED
28	3AY-F5381-01-91	AXLE, WHEEL EJE DE RUEDA	1	1	WHITE CHROME
29	90185-12046	NUT, SELF-LOCKING TUERCA AUTOBLOCANTE	1	1	
30	90201-12688	WASHER, PLATE ARANDELA PLANA	1	1	
31	90387-121U1-91	COLLAR COLLAR	1	1	WHITE CHROME
32	90387-181U2-91	COLLAR COLLAR	1	1	WHITE CHROME
33	90170-18165	NUT TUERCA	1	1	
34	2R2-F5388-00-91	PULLER, CHAIN 1 TIRADOR DE CADENA 1	1	1	WHITE CHROME
35	2R2-F5389-00-91	PULLER, CHAIN 2 TIRADOR DE CADENA 2	1	1	WHITE CHROME
36	95307-06600	NUT TUERCA	2	2	
37	90201-061A5	WASHER, PLATE ARANDELA PLANA	2	2	
38	92907-06100	WASHER, SPRING ARANDELA	2	2	
39	94568-39098	CHAIN (D.I.D 428 98L) CADENA (D.I.D 428 98L)	1	1	
40	94668-37001	.JOINT, CHAIN (D.I.D 428) .CONECTOR DE CADENA (D.I.D 428)	1	1	
41	3AY-F5371-00-91	BAR, TENSION BARRA TENSORA	1	1	WHITE CHROME
42	90109-08183	BOLT PERNO	1	1	
43	92907-08100	WASHER, SPRING ARANDELA	1	1	
44	90501-205E8-91	SPRING, COMPRESSION RESORTE DE COMPRESION	1	1	WHITE CHROME
45	90201-087F0	WASHER, PLATE ARANDELA PLANA	1	1	
46	95307-08700	NUT TUERCA	2	2	
47	90468-12007	CLIP PRESILLA	2	2	

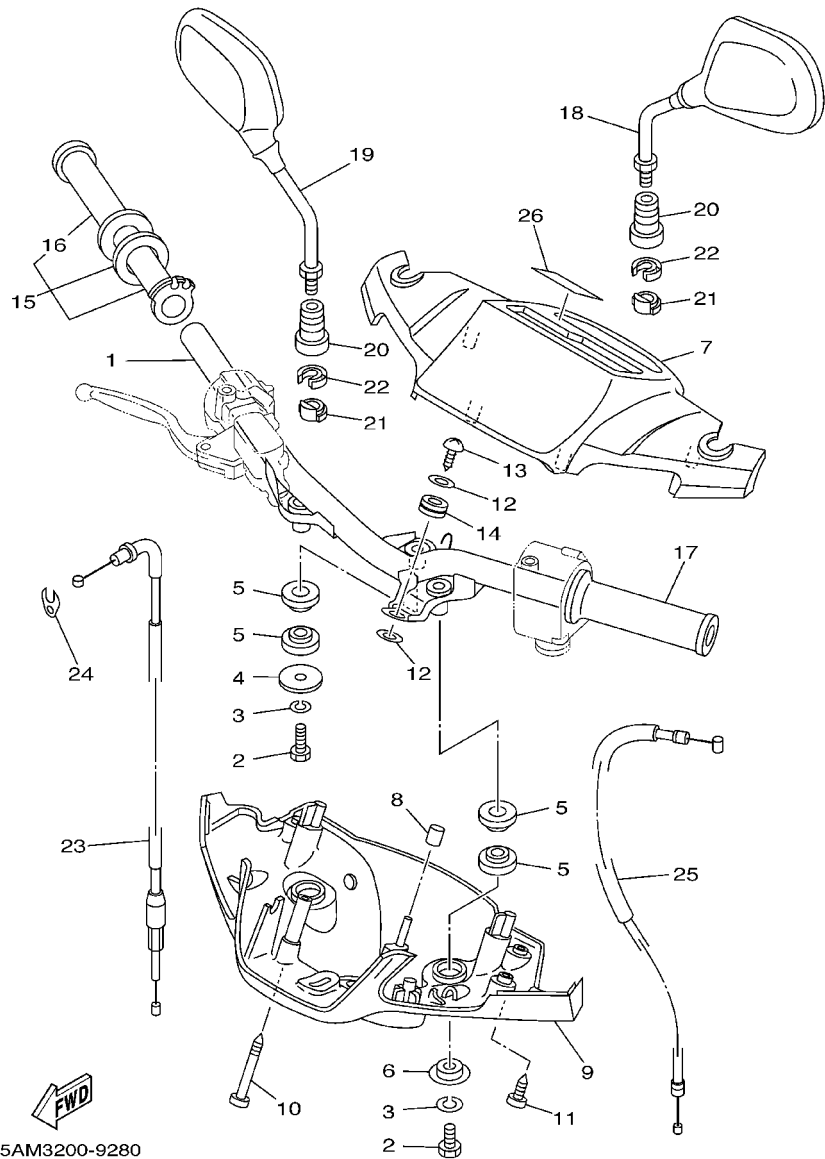

5AM3200-9280

FIG. 28 STEERING HANDLE. CABLE MANUBRIO. CABLE

REF. NO.	PART NO. CODIGO NO.	DESCRIPTION DESCRIPTION	5AM3	5AM4	REMARKS OBSERVACION
1	3XA-F6210-00-91	HANDLE MANUBRIO	1	1	WHITE CHROME
2	97007-08016	BOLT PERNO	3	3	
3	92907-08100	WASHER, SPRING ARANDELA	3	3	
4	90201-08612	WASHER, PLATE ARANDELA PLANA	1	1	
5	3AY-F6113-00	DAMPER AMORTIGUADOR	6	6	
6	4ST-F6129-00	WASHER ARANDELA	2	2	
7	4NS-F6213-00-33	COVER, UPPER CUBIERTA SUPERIOR	1	1	UR YB
	4NS-F6213-00-MW	COVER, UPPER CUBIERTA SUPERIOR	1	1	UR BIB
	4NS-F6213-00-21	COVER, UPPER CUBIERTA SUPERIOR	1	1	UR VRC1
8	3XA-F622F-00	DAMPER, LOCATING 1 AMORTIGUADOR, DE UBICACION 1	1	1	
9	3XA-F6215-00-33	COVER, LOWER CUBIERTA INFERIOR	1	1	UR YB
	3XA-F6215-00-MW	COVER, LOWER CUBIERTA INFERIOR	1	1	UR BIB
	3XA-F6215-00-21	COVER, LOWER CUBIERTA INFERIOR	1	1	UR VRC1
10	90167-04033	SCREW, TAPPING TORNILLO DE ROSCA HEMBRA	2	2	
11	97707-50016	SCREW, TAPPING TORNILLO ROSCA HEMBRA	3	3	
12	92907-10200	WASHER, PLAIN ARANDELA	2	2	
13	97707-50014	SCREW, TAPPING TORNILLO ROSCA HEMBRA	1	1	
14	90480-01321	GROMMET TAPON	1	1	
15	4ST-F6240-00	GRIP ASSY EMPUNADURA COMPLETA	1	1	
16	3XA-F6242-00	.GRIP (RIGHT) EMPUNADURA (MD)	1	1	
17	3XA-F6241-00	GRIP EMPUNADURA	1	1	
18	3XA-F6280-01	REAR VIEW MIRROR ASSY (LEFT) ESPEJO COMPLETO (IZQUIERDO)	1	1	
19	3XA-F6290-01	REAR VIEW MIRROR ASSY (RIGHT) ESPEJO COMPLETO (DERECHO)	1	1	
20	3FS-F629T-00	BOOT 1 FUNDA 1	2	2	
21	3XA-F6326-00	GROMMET TAPON PROTECTOR	2	2	
22	3XA-F6129-00	WASHER ARANDELA	2	2	
23	4ST-F6311-00	CABLE, THROTTLE 1 CABLE DE ACELERADOR 1	1	1	

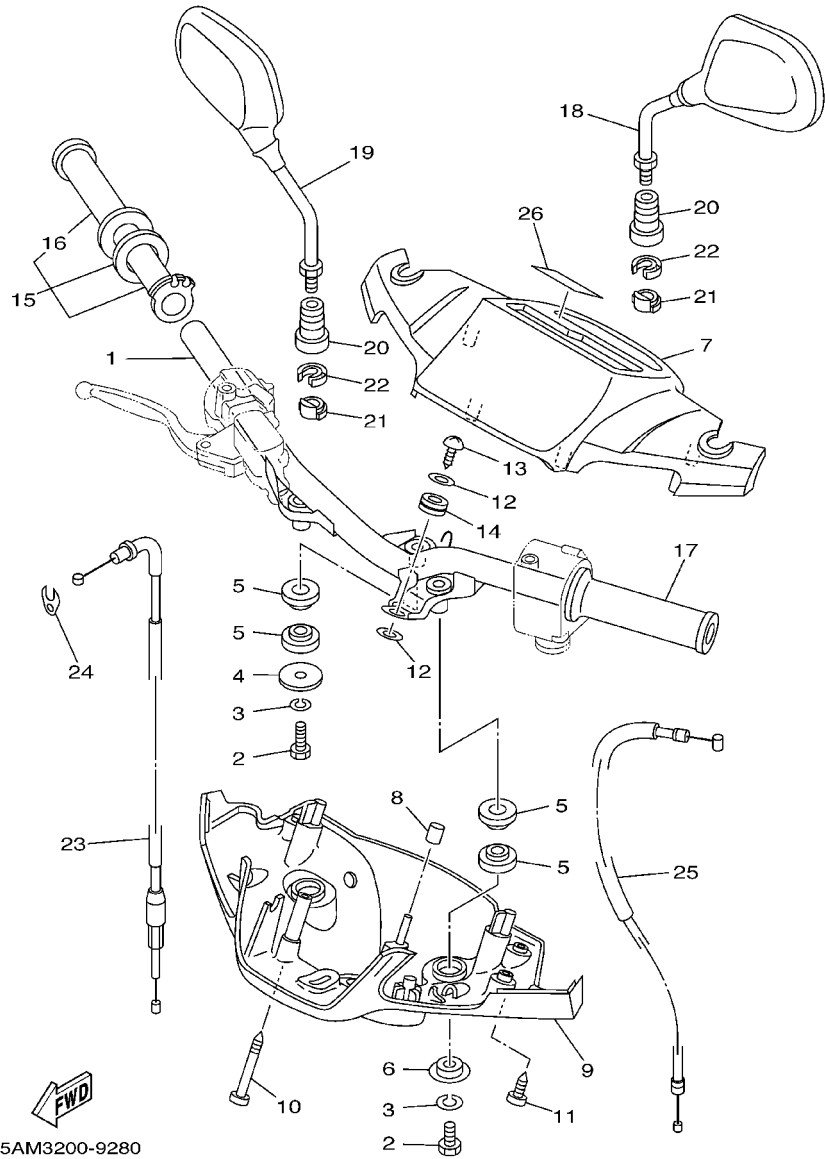

**FIG. 28 STEERING HANDLE. CABLE MANUBRIO. CABLE**

REF. NO.	PART NO. CODIGO NO.	DESCRIPTION DESCRIPTION	5AM3	5AM4	REMARKS OBSERVACION
24	4ST-F6393-00	HOLDER SOPORTE	1	1	
25	4ST-F6331-00	CABLE, STARTER 1 CABLE DE ARRANQUE 1	1	1	
26	4US-F6219-00	EMBLEM EMBLEMA	1	1	

**FIG. 29 FRONT MASTER CYLINDER CILINDRO MAESTRO DELANTERO**

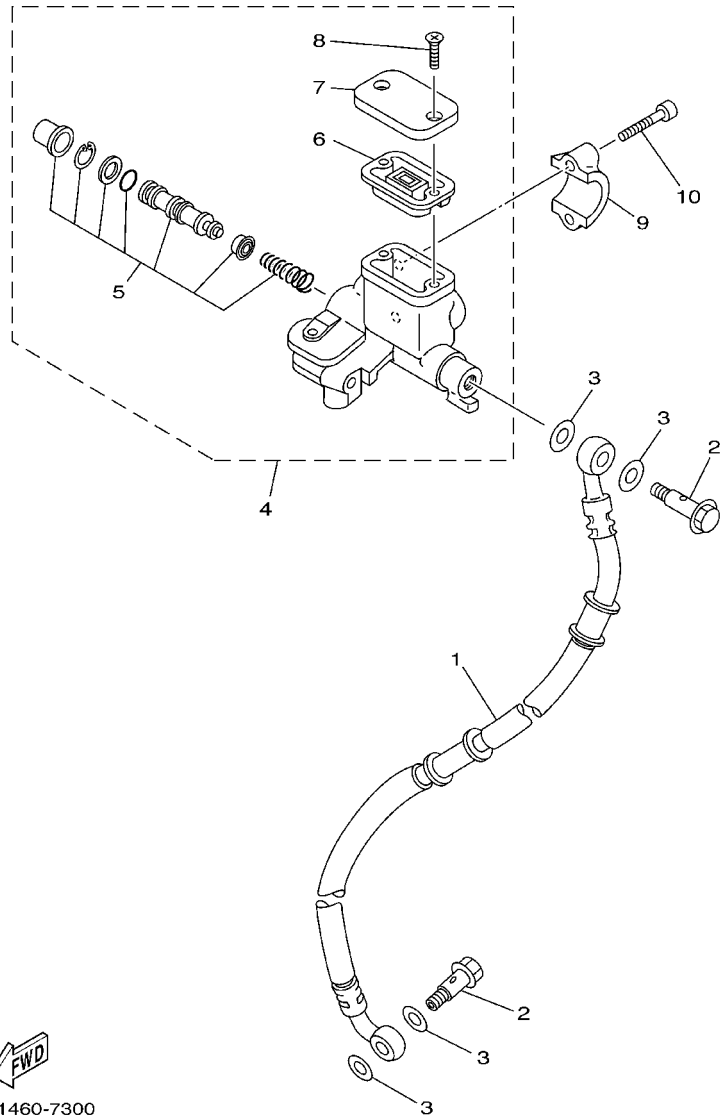

**FWD**  
4US1460-7300

REF. NO.	PART NO. CODIGO NO.	DESCRIPTION DESCRIPTION	5AM3	5AM4	REMARKS OBSERVACION
1	4US-F5872-00	HOSE, BRAKE 1 MANGUERA DE FRENO 1	1	1	
2	90401-10159	BOLT, UNION PERNO DE UNION	2	2	
3	90201-10118	WASHER, PLATE ARANDELA PLANA	4	4	
4	3YK-25870-02	MASTER CYLINDER SUB ASSY CILINDRO MAESTRO COMPLETO	1	1	
5	3RW-W0041-02	.CYLINDER KIT, MASTER JUEGO DE CILINDRO MAESTRO	1	1	
6	3YR-25854-00	.DIAPHRAGM, RESERVOIR DIAFRAGMA TANQUE RESERVA	1	1	
7	3YR-25852-00	.CAP, RESERVOIR TAPA DE TANQUE DE RESERVA	1	1	
8	98706-04012	.SCREW, FLAT HEAD TORNILLO CON CABEZA PLANA	2	2	
9	3YK-25867-00	BRACKET, MASTER CYLINDER SOPORTE DE CILINDRO MAESTRO	1	1	
10	91317-06025	BOLT PERNO	2	2	

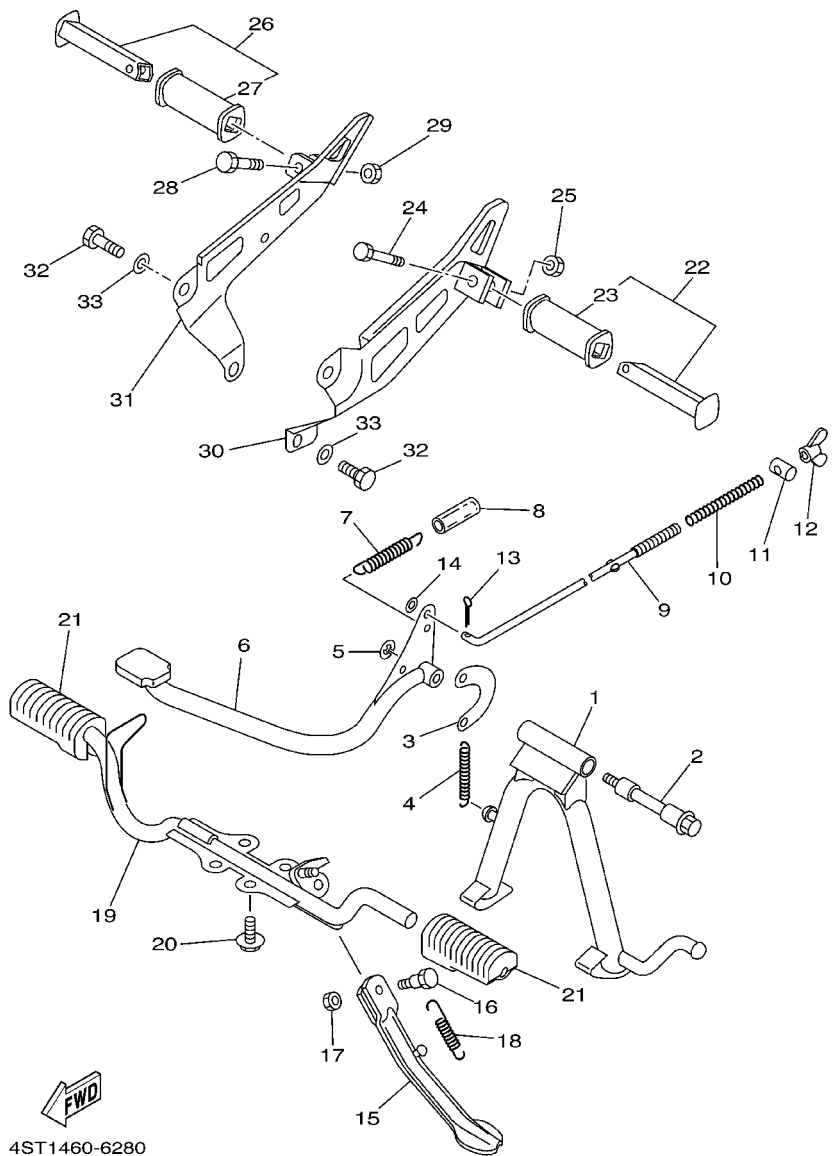

4ST1460-6280

FIG. 30 STAND. FOOTREST

SOPORTE. APOYAPIE

REF. NO.	PART NO. CODIGO NO.	DESCRIPTION DESCRIPTION	5AM3	5AM4	REMARKS OBSERVACION
1	4ST-F7111-00-33	STAND, MAIN PUNTAL PRINCIPAL	1	1	YAMAHA BLACK
2	3XA-F7112-01-91	SHAFT, MAIN STAND EJE DE PUNTAL PRINCIPAL	1	1	WHITE CHROME
3	3AY-F7115-00-91	LINK, MAIN STAND CONEXION DE PUNTAL PRINCIPAL	1	1	WHITE CHROME
4	90506-29054	SPRING, TENSION RESORTE DE TENSION	1	1	
5	93430-12008	CIRCLIP SEGURO	1	1	
6	4ST-F7211-00-93	PEDAL, BRAKE PEDAL DE FRENO	1	1	CHROME PLATE
7	90506-20041	SPRING, TENSION RESORTE DE TENSION	1	1	
8	3XA-F7235-00	COVER, DUST CUBIERTA DE POLVO	1	1	
9	4ST-F7231-00-91	ROD, BRAKE VARILLA DE FRENO	1	1	WHITE CHROME
10	90501-10245-91	SPRING, COMPRESSION RESORTE DE COMPRESION	1	1	WHITE CHROME
11	90249-12008	PIN PASADOR	1	1	
12	90175-06013	NUT, WING TUERCA MARIPOSA	1	1	
13	91401-20015	PIN, COTTER CHAVETA	1	1	
14	92907-06600	WASHER, PLATE ARANDELA	1	1	
15	4ST-F7311-00-33	STAND, SIDE PUNTAL LATERAL	1	1	YAMAHA BLACK
16	90109-08034	BOLT PERNO	1	1	
17	95317-08700	NUT TUERCA	1	1	
18	90506-25047	SPRING, TENSION RESORTE DE TENSION	1	1	
19	4ST-F7411-00-33	FOOTREST 1 APOYAPIE 1	1	1	YAMAHA BLACK
20	95817-08016	BOLT, FLANGE TUERCA DE REBORDE	4	4	
21	2ET-F7413-00	COVER, FOOTREST CUBIERTA DE APOYAPIE	2	2	
22	3XA-F7430-00	REAR FOOTREST ASSY 1 APOYAPIE POSTERIOR COMPLETO 1	1	1	
23	3XA-F7433-00	.COVER, REAR FOOTREST .CUBIERTA APOYAPIE TRASERO	1	1	
24	90109-066F1	BOLT PERNO	1	1	
25	95617-06100	NUT, U TUERCA AUTOBLOCANTE	1	1	
26	3XA-F7440-00	REAR FOOTREST ASSY 2 APOYAPIE POSTERIOR COMPLETO 2	1	1	
27	3XA-F7433-00	.COVER, REAR FOOTREST .CUBIERTA APOYAPIE TRASERO	1	1	

FIG. 30 STAND. FOOTREST

SOPORTE. APOYAPIE

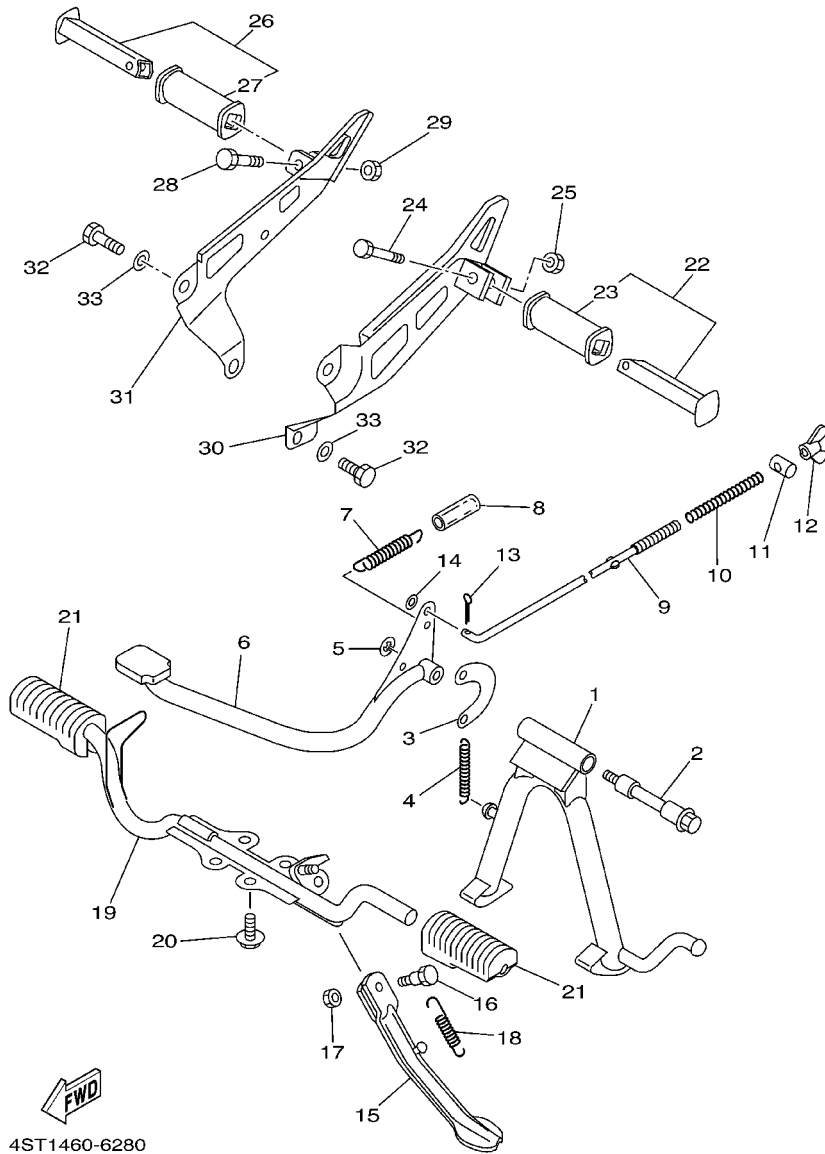

4ST1460-6280

REF. NO.	PART NO. CODIGO NO.	DESCRIPTION DESCRIPTION	5AM3	5AM4	REMARKS OBSERVACION
28	90109-066F1	BOLT PERNO	1	1	
29	95617-06100	NUT, U TUERCAAUTOBLOCANTE	1	1	
30	3XA-F7452-00-WN	BRACKET, FOOTREST 1 SOPORTE, DE APOYAPIE 1	1	1	CIRCUIT SILVER
31	3XA-F7462-00-WN	BRACKET, FOOTREST 2 SOPORTE, DE APOYAPIE 2	1	1	CIRCUIT SILVER
32	97017-10020	BOLT PERNO	2	2	
33	92907-10600	WASHER, PLATE ARANDELA	2	2	
-----					
-----					
-----					
-----					
-----					
-----					

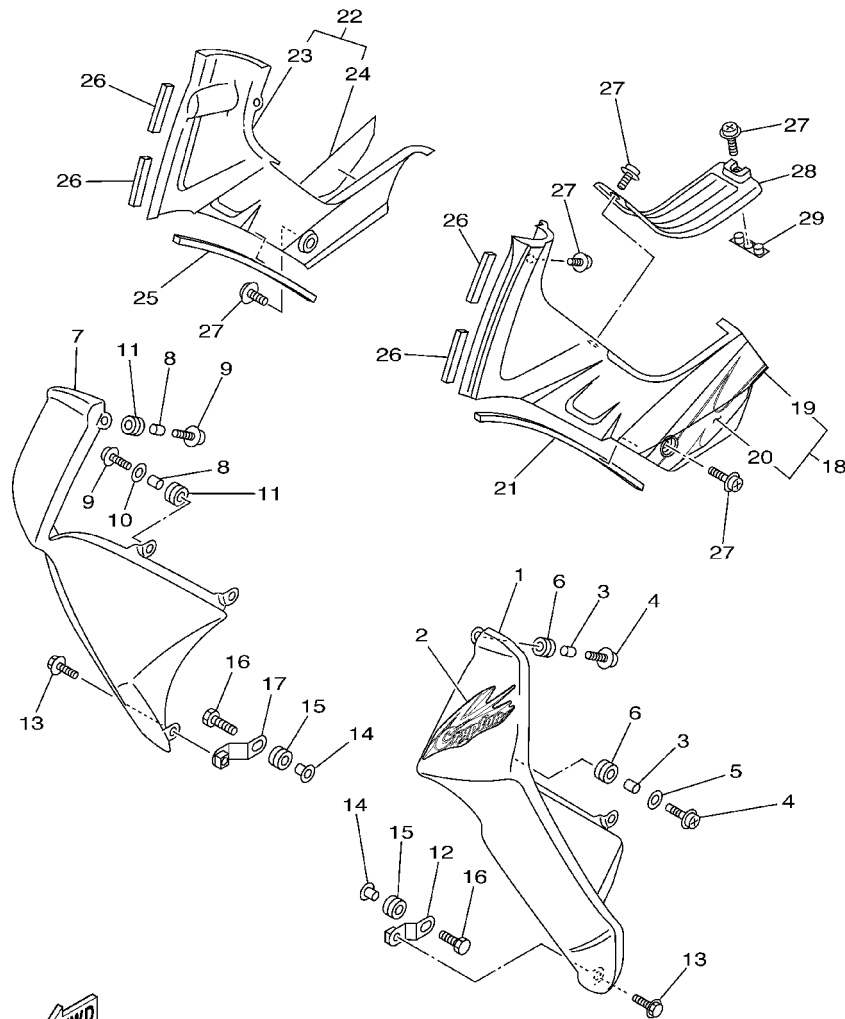

5AM3200-9310

FIG. 31 LEG SHIELD

PATA PROTEGIDA

REF. NO.	PART NO. CODIGO NO.	DESCRIPTION DESCRIPTION	5AM3	5AM4	REMARKS OBSERVACION
1	4ST-F8311-00	LEG SHIELD 1 PROTECCION DE PATA 1	1	1	UR YB
	4ST-F8311-10	LEG SHIELD 1 PROTECCION DE PATA 1	1	1	UR BIB
	4ST-F8311-20	LEG SHIELD 1 PROTECCION DE PATA 1	1	1	UR WHITE FOR VRC1
2	5AM-F8368-00	EMBLEM EMBLEMA	1	1	UR FOR YB GREEN GRP
	5AM-F8368-10	EMBLEM EMBLEMA	1	1	UR FOR YB WHITE GRP
	5AM-F8368-20	EMBLEM EMBLEMA	1	1	UR FOR BIB
	5AM-F8368-30	EMBLEM EMBLEMA	1	1	UR FOR VRC1
3	90387-060G7	COLLAR COLLAR	2	2	
4	90159-06085	SCREW, WITH WASHER TORNILLO CON VALONA	2	2	
5	90201-06557	WASHER, PLATE ARANDELA PLANA	1	1	
6	90480-13398	GROMMET TAPON	2	2	
7	4ST-F8312-00	LEG SHIELD 2 PROTECCION DE PATA 2	1	1	UR YB
	4ST-F8312-10	LEG SHIELD 2 PROTECCION DE PATA 2	1	1	UR BIB
	4ST-F8312-20	LEG SHIELD 2 PROTECCION DE PATA 2	1	1	UR WHITE FOR VRC1
8	90387-060G7	COLLAR COLLAR	2	2	
9	90159-06085	SCREW, WITH WASHER TORNILLO CON VALONA	2	2	
10	90201-06557	WASHER, PLATE ARANDELA PLANA	1	1	
11	90480-13398	GROMMET TAPON	2	2	
12	4ST-F8321-00	STAY 1 SOPORTE 1	1	1	
13	95807-06014	BOLT, FLANGE TUERCA DE REBORDE	2	2	
14	90560-06201	SPACER SEPARADOR	2	2	
15	90480-13398	GROMMET TAPON	2	2	
16	97007-06020	BOLT PERNO	2	2	
17	4ST-F8322-00	STAY 2 SOPORTE 2	1	1	
18	5AM-F8380-00-33	WINDSCREEN ASSY VISERA COMPLETO	1		UR YB GREEN GRP
	5AM-F8380-10-33	WINDSCREEN ASSY VISERA COMPLETO	1	1	UR YB WHITE GRP
	5AM-F8380-20-MW	WINDSCREEN ASSY VISERA COMPLETO	1	1	UR BIB

FIG. 31 LEG SHIELD

PATA PROTEGIDA

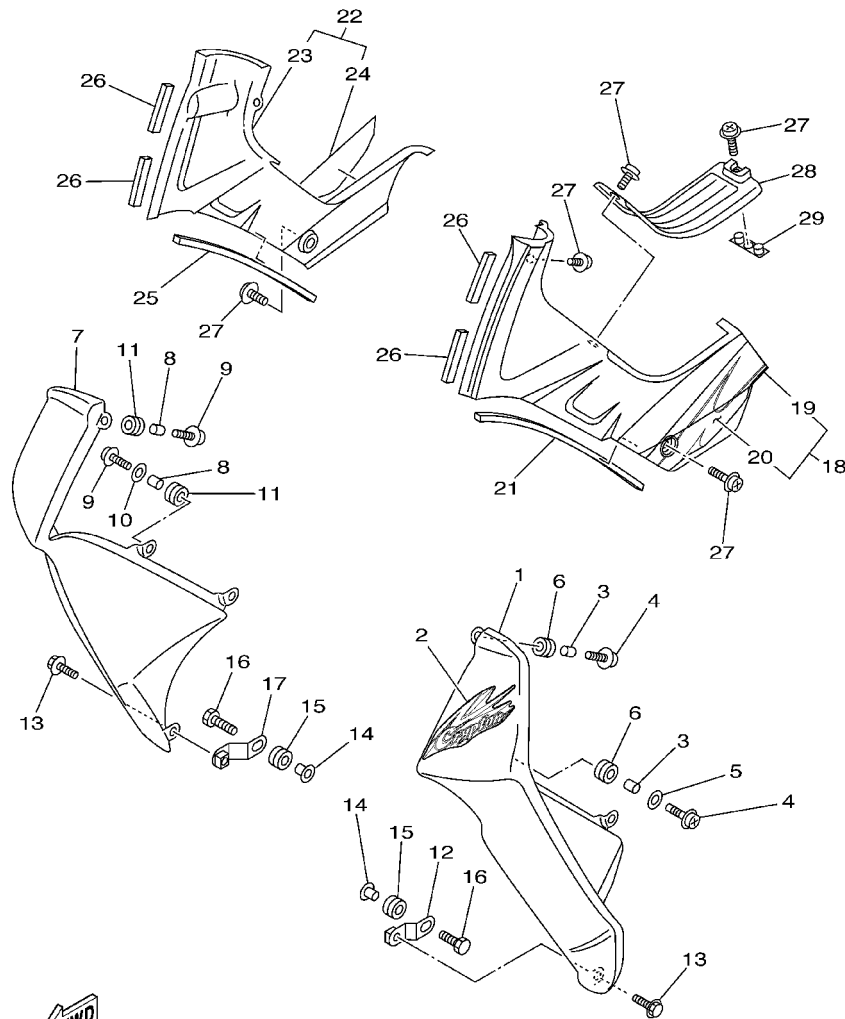

5AM3200-9310

REF. NO.	PART NO. CODIGO NO.	DESCRIPTION DESCRIPTION	5AM3	5AM4	REMARKS OBSERVACION
18	5AM-F8380-30-21	WINDSCREEN ASSY VISERA COMPLETO	1	1	UR VRC1
19	4ST-F8385-00-33	.COVER, LOWER .CUBIERTA INFERIOR	1	1	UR YB
	4ST-F8385-00-MW	.COVER, LOWER .CUBIERTA INFERIOR	1	1	UR BIB
	4ST-F8385-00-21	.COVER, LOWER .CUBIERTA INFERIOR	1	1	UR VRC1
20	5AM-F8391-00	.GRAPHIC 1 .CALCOMANIA DE BOVEDA 1	1		UR FOR YB GREEN GRP
	5AM-F8391-10	.GRAPHIC 1 .CALCOMANIA DE BOVEDA 1	1	1	UR FOR YB WHITE GRP
	5AM-F8391-20	.GRAPHIC 1 .CALCOMANIA DE BOVEDA 1	1	1	UR FOR BIB
	5AM-F8391-30	.GRAPHIC 1 .CALCOMANIA DE BOVEDA 1	1	1	UR FOR VRC1
21	4ST-F8435-00	DAMPER 4 AMORTIGUADOR 4	1	1	
22	5AM-F8390-00-33	WINDSCREEN ASSY VISERA COMPLETO	1		UR YB GREEN GRP
	5AM-F8390-10-33	WINDSCREEN ASSY VISERA COMPLETO	1	1	UR YB WHITE GRP
	5AM-F8390-20-MW	WINDSCREEN ASSY VISERA COMPLETO	1	1	UR BIB
	5AM-F8390-30-21	WINDSCREEN ASSY VISERA COMPLETO	1	1	UR VRC1
23	4ST-F8395-00-33	.COVER, UNDER .CUBIERTA INFERIOR	1	1	UR YB
	4ST-F8395-00-MW	.COVER, UNDER .CUBIERTA INFERIOR	1	1	UR BIB
	4ST-F8395-00-21	.COVER, UNDER .CUBIERTA INFERIOR	1	1	UR VRC1
24	5AM-F8392-00	.GRAPHIC 2 .CALCOMANIA DE BOVEDA 2	1	1	UR FOR YB GREEN GRP
	5AM-F8392-10	.GRAPHIC 2 .CALCOMANIA DE BOVEDA 2	1	1	UR FOR YB WHITE GRP
	5AM-F8392-20	.GRAPHIC 2 .CALCOMANIA DE BOVEDA 2	1	1	UR FOR BIB
	5AM-F8392-30	.GRAPHIC 2 .CALCOMANIA DE BOVEDA 2	1	1	UR FOR VRC1
25	4ST-F8435-00	DAMPER 4 AMORTIGUADOR 4	1	1	
26	56J-23398-00	MOLD, FRONT MOLDURA DELANTERA	4	4	
27	90159-06181	SCREW, WITH WASHER TORNILLO CON VALONA	5	5	
28	4ST-F834V-00	PROTECTOR 1 PROTECTOR 1	1	1	
29	3XA-F836T-00	DAMPER, LOCATING 1 AMORTIGUADOR DE MONTAJE 1	1	1	



FIG. 33 STARTING MOTOR

MOTOR DE ARRANQUE

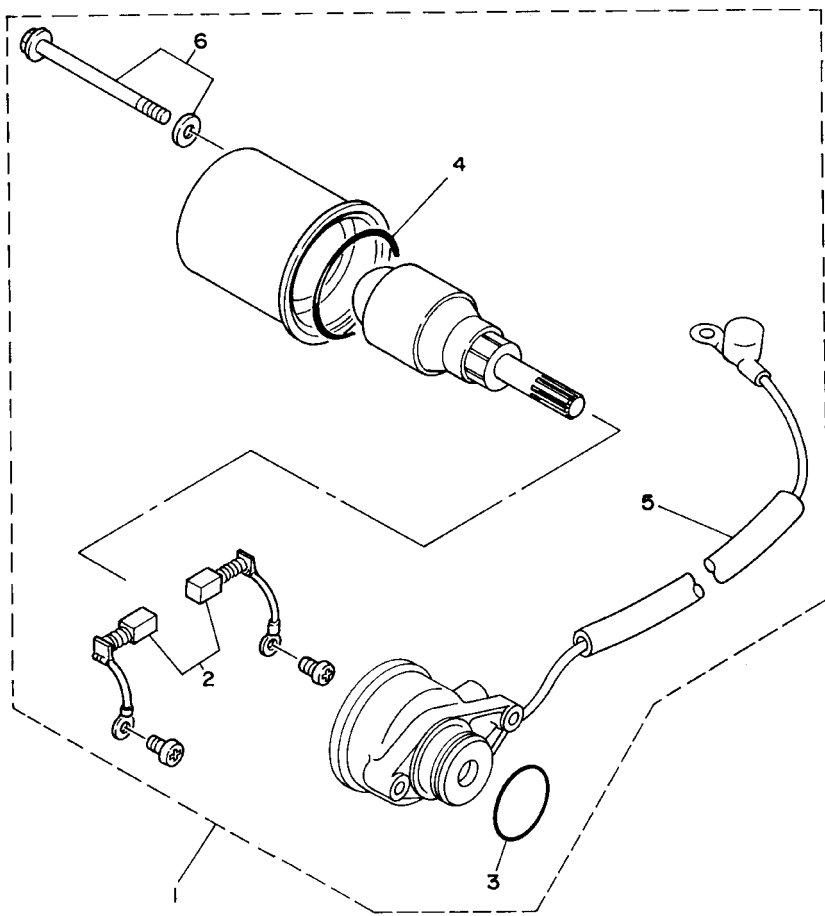

REF. NO.	PART NO. CODIGO NO.	DESCRIPTION DESCRIPTION	5AM3	5AM4	REMARKS OBSERVACION
1	4ST-H1800-00	STARTING MOTOR ASSY MOTOR DE ARRANQUE COMPLETO	1	1	
2	4ST-81801-00	.BRUSH SET .JUEGO DE ESCOBILLA	1	1	
3	4ST-81826-00	.O-RING .ANILLO GOMA	1	1	
4	4ST-81861-00	.GASKET .EMPAQUETADURA	1	1	
5	4ST-H183G-00	.CORD COMP. .CABLE COMPL.	1	1	
6	4ST-81828-00	.BOLT 2 .ARANDELA DE EMPUJE 2	1	1	

  
4STI460-6310

FIG. 34 FLASHER LIGHT

LUZ DE DESTELLADOR

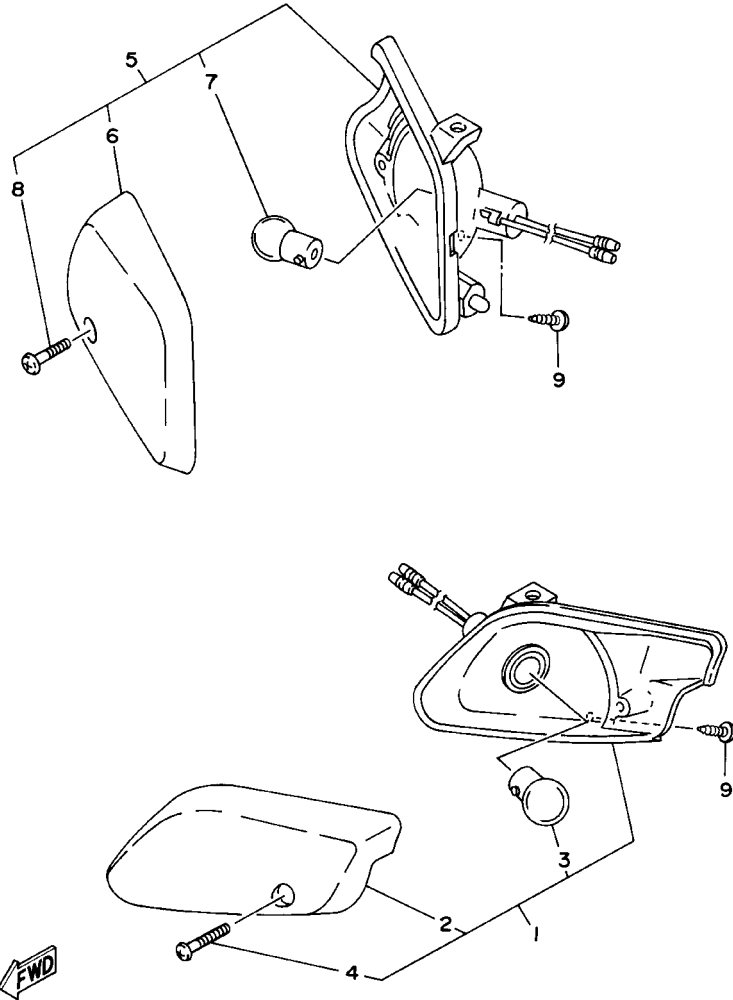

3YR1440-1320

REF. NO.	PART NO. CODIGO NO.	DESCRIPTION DESCRIPTION	5AM3	5AM4	REMARKS OBSERVACION
1	3XA-H3310-00	FRONT FLASHER LIGHT ASSY 1 DESTELLADOR DE LUZ DELANT. 1	1	1	
2	3XA-H3312-00	.LENS, FLASHER .LENTE DE DESTELLADOR	1	1	
3	3XA-H3311-00	.BULB, FLASHER (12V-10W) .BOMBILLA DE DESTELLADOR (12V-10W)	1	1	
4	97706-40016	.SCREW, TAPPING .TORNILLO, ROSCA CHAPA	1	1	
5	3XA-H3320-01	FRONT FLASHER LIGHT ASSY 2 DESTELLADOR DE LUZ DELANT. 2	1	1	
6	3XA-H3322-00	.LENS, FLASHER 2 .LENTE DE INTERMITENTE 2	1	1	
7	3XA-H3311-00	.BULB, FLASHER (12V-10W) .BOMBILLA DE DESTELLADOR (12V-10W)	1	1	
8	97706-40016	.SCREW, TAPPING .TORNILLO, ROSCA CHAPA	1	1	
9	97707-40014	SCREW, TAPPING TORNILLO ROSCA HEMBRA	2	2	

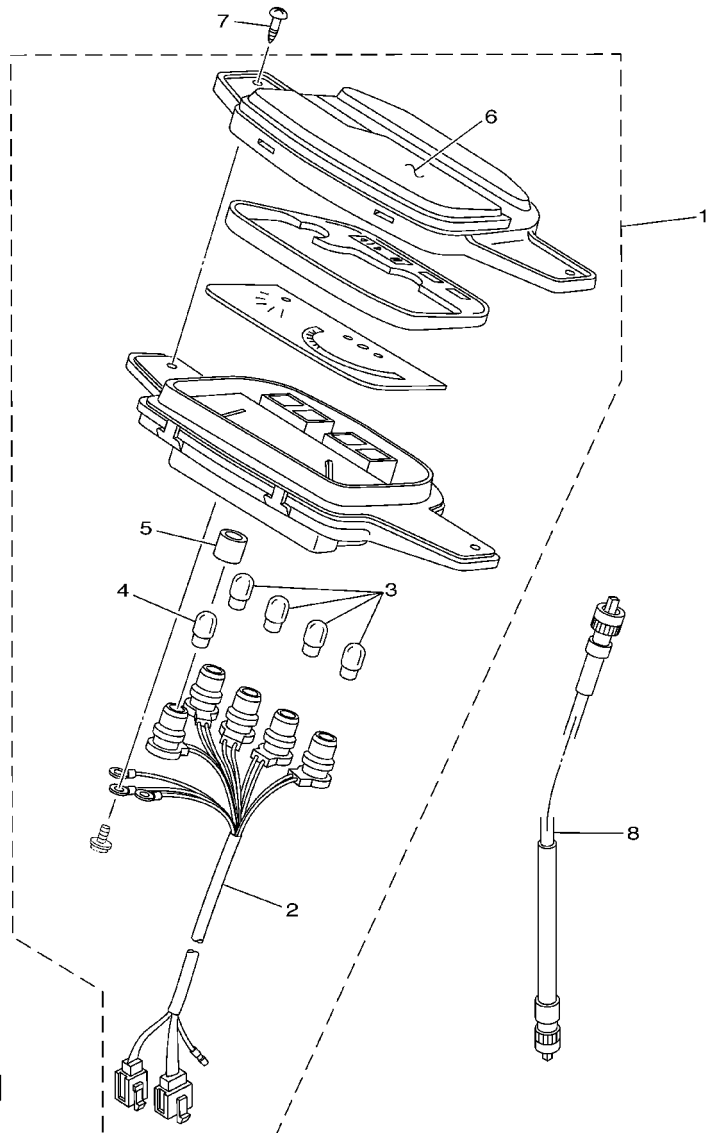

5AM3200-9350



FIG. 35 METER

MEDIDOR

REF. NO.	PART NO. CODIGO NO.	DESCRIPTION DESCRIPTION	5AM3	5AM4	REMARKS OBSERVACION
1	4ST-H3510-00	SPEEDOMETER ASSY VELOCIMETRO COMPL.	1	1	
2	4ST-H3509-00	.SOCKET CORD ASSY .ENCASTRE DE CABLE COMPLETO	1	1	
3	5R0-83517-V0	.BULB (12V-3.4W) .AMPOLLETA (12V-3.4W)	4	4	
4	3AY-83517-V0	.BULB (12V-1.7W) .AMPOLLETA (12V-1.7W)	1	1	
5	2XF-83781-V0	.TUBE .TUBO	1	1	
6	3XA-H353K-00	.GLASS PLATE .CUBIERTA DE MEDIDOR	1	1	
7	97707-50016	SCREW, TAPPING TORNILLO ROSCA HEMBRA	2	2	
8	4NS-H3550-00	SPEEDOMETER CABLE ASSY CABLE DE VELOCIMETRO COMPLETO	1	1	

FIG. 36 HEADLIGHT

FARO DELANTERO

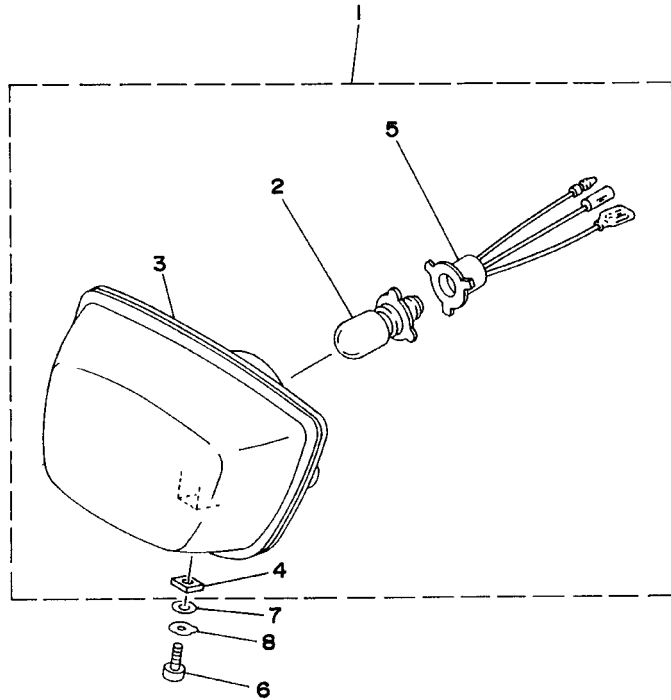

REF. NO.	PART NO. CODIGO NO.	DESCRIPTION DESCRIPTION	5AM3	5AM4	REMARKS OBSERVACION
1	3XA-H4310-00	HEADLIGHT UNIT ASSY UNIDAD DE FARO DELANTERO COMPL	1	1	
2	3AY-H4314-00	.BULB (12V-30/30W) .BOMBILLA DE FARO DELANTERO	1	1	
3	3XA-H4120-00	.LENS ASSY .LENTES COMPLETO	1	1	
4	3XA-H4317-00-92	.NUT .TUERCA	1	1	YELLOW CROME
5	3AY-H4140-V0	.SOCKET CORD ASSY .ENCASTRE DE CABLE COMPLETO	1	1	
6	97027-06012	BOLT PERNO	1	1	
7	90201-065F3	WASHER, PLATE ARANDELA PLANA	1	1	
8	90206-06090	WASHER, WAVE ARANDELA ONDULADA	1	1	



4ST1460-6340

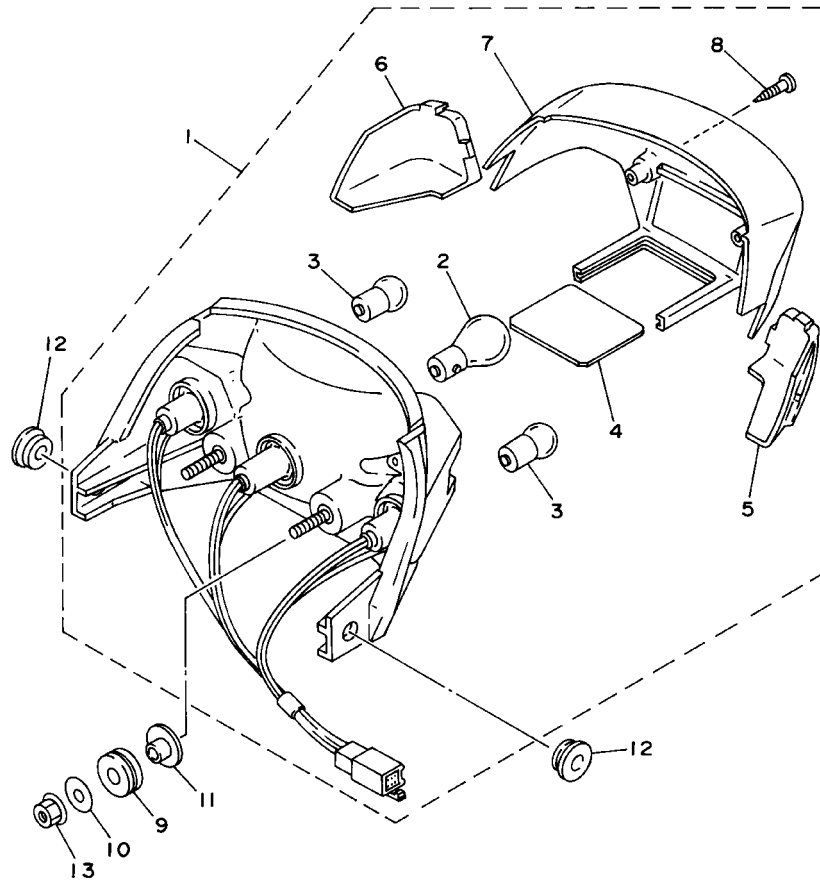

3YR1440-1350

FIG. 37 TAILLIGHT

LUZ DE COLA

REF. NO.	PART NO. CODIGO NO.	DESCRIPTION DESCRIPTION	5AM3	5AM4	REMARKS OBSERVACION
1	3XA-H4710-00	TAILLIGHT UNIT ASSY CONJT. FARO TRASERO	1	1	
2	3XA-H4714-00	.BULB (12V 21/5W) .BOMBILLA (12V 21/5W)	1	1	
3	3XA-83311-00	.BULB, FLASHER (12V-10W) .BOMBILLA DE DESTELLADOR (12V-10W)	2	2	
4	3XA-8472F-00	.LENS, LICENCE LIGHT .LENTE DE LUZ DE LICENCIA	1	1	
5	3XA-H3332-00	.LENS, FLASHER .LENTE DE DESTELLADOR	1	1	
6	3XA-H3342-00	.LENS, FLASHER 2 .LENTE DE DESTELLADOR 2	1	1	
7	3XA-H4721-00	.LENS, TAILLIGHT .LENTE DE FARO TRASERO	1	1	
8	97706-40625	.SCREW, TAPPING .TORNILLO, ROSCA CHAPA	2	2	
9	90480-18276	GROMMET TAPON	2	2	
10	90201-063J2	WASHER, PLATE ARANDELA PLANA	2	2	
11	90387-066M1	COLLAR COLLAR	2	2	
12	90480-13426	GROMMET TAPON	2	2	
13	95707-06500	NUT, FLANGE TUERCA DE BRIDA	2	2	

FIG. 38 HANDLE SWITCH. LEVER

INTERRUPTOR DE MANIJA. PALANCA

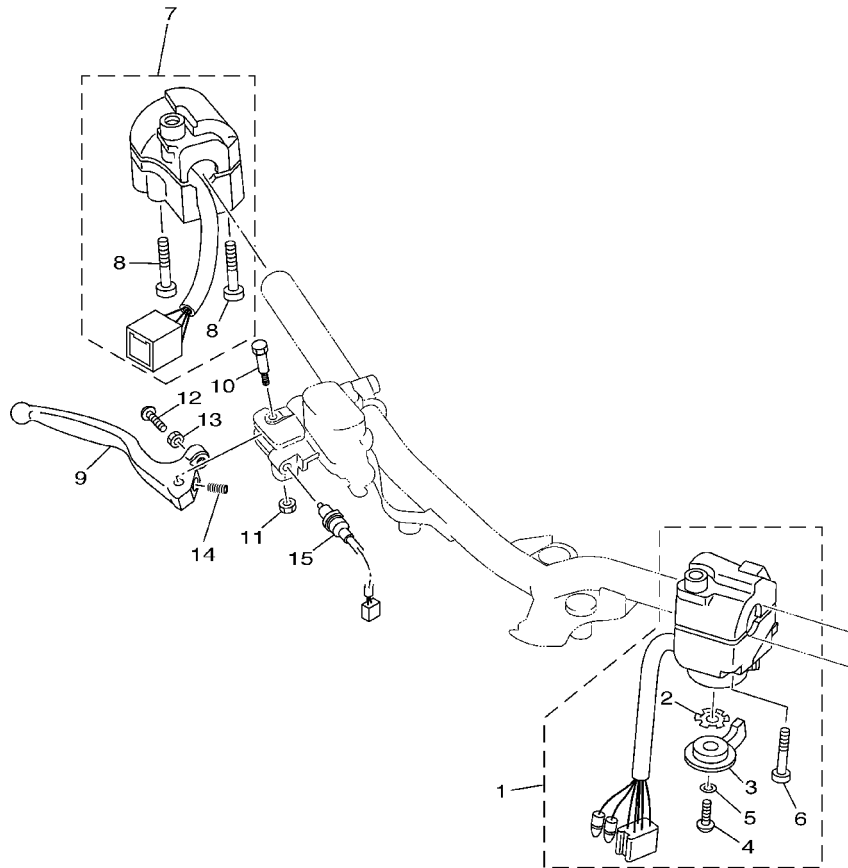

REF. NO.	PART NO. CODIGO NO.	DESCRIPTION DESCRIPTION	5AM3	5AM4	REMARKS OBSERVACION
1	4ST-H3973-00	SWITCH, HANDLE 3 INTERRUPTOR DE MANIJA 3	1	1	
2	90209-10131	.WASHER .ARANDELA DE SEPARACION	1	1	
3	4ST-83941-00	.LEVER, STARTER .PALANCA DE ARRANQUE	1	1	
4	98506-06008	.SCREW, PAN HEAD .TORNILLO, DE CABEZA CRUZADA	1	1	
5	92901-06200	.WASHER, PLAIN .ARANDELA PLANA	1	1	
6	98506-05035	.SCREW, PAN HEAD .TORNILLO, DE CABEZA CRUZADA	2	2	
7	3XA-H3975-00	SWITCH, HANDLE 2 INTERRUPTOR MANIJA 2	1	1	
8	98506-05040	.SCREW, PAN HEAD .TORNILLO, DE CABEZA CRUZADA	2	2	
9	4US-H3922-00	LEVER 2 PALANCA 2	1	1	
10	90109-06577	BOLT PERNO	1	1	
11	95607-06100	NUT, U TUERCA AUTOBLOCANTE	1	1	
12	90149-06131	SCREW TORNILLO DE REGLAJE	1	1	
13	95607-06100	NUT, U TUERCA AUTOBLOCANTE	1	1	
14	90501-10312	SPRING, COMPRESSION RESORTE DE COMPRESION	1	1	
15	4US-H3980-00	FRONT STOP SWITCH ASSY INTERRUP.PARADA DELANTERO	1	1	



5AM3200-9380

FIG. 39 ELECTRICAL 1

EQUIPO ELECTRICO 1

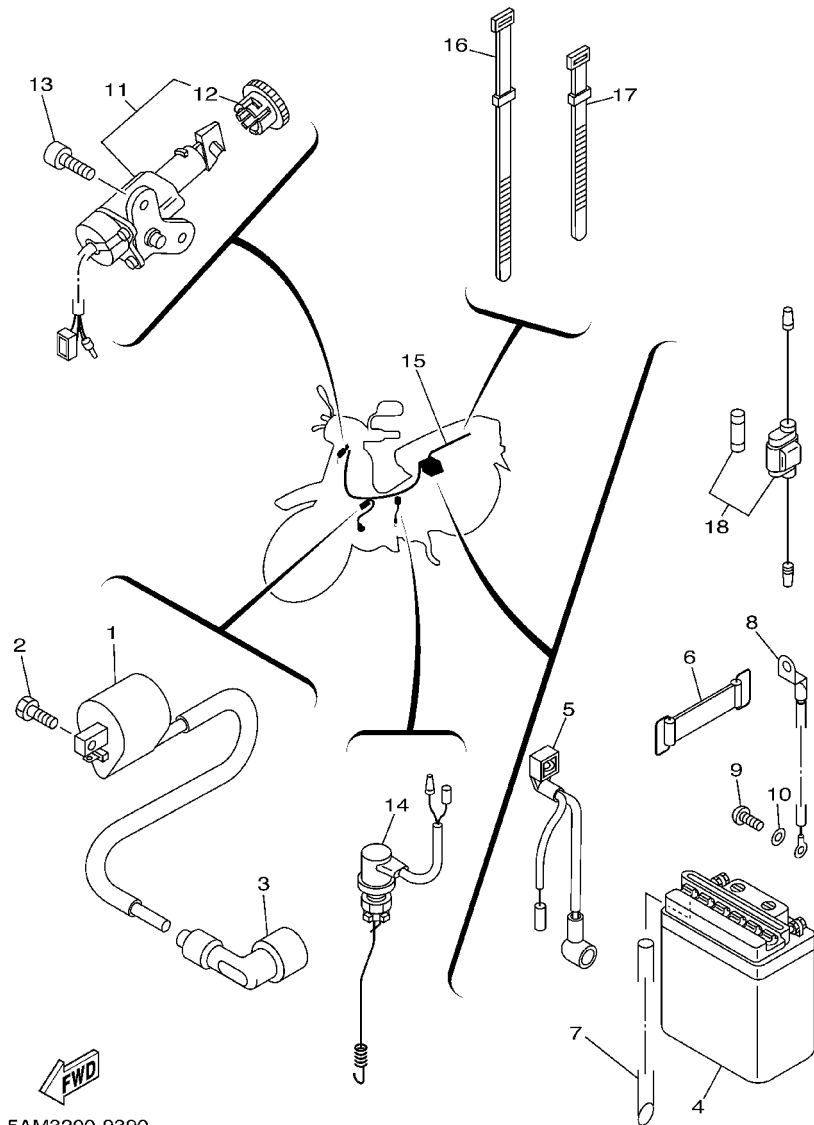

FWD  
5AM3200-9390

REF. NO.	PART NO. CODIGO NO.	DESCRIPTION DESCRIPTION	5AM3	5AM4	REMARKS OBSERVACION
1	4ST-H2310-00	IGNITION COIL ASSY BOBINA DE ENCENDIDO COMPLETA	1	1	
2	97017-06016	BOLT PERNO	2	2	
3	4BP-82370-00	PLUG CAP ASSY TAPON DE BUJIA COMPLT	1	1	
4	3AY-H2110-00	BATTERY ASSY (YB5L-B 12V-5AH) BATERIA COMPLETA (YB5L-B 12V-5AH)	1	1	UR YUASA
	3AY-H2110-10	BATTERY ASSY (GM5Z-3B) BATERIA COMPLETA (GM5Z-3B)	1	1	UR GS
5	3AY-H2115-00	WIRE, PLUS LEAD CABLE CONDUCTOR POSITIVO	1	1	
6	4ST-H2131-00	BAND, BATTERY TIRANTE DE BATERIA	1	1	
7	90445-08170	HOSE (L330) TUBO (L330)	1	1	
8	4ST-H2116-00	WIRE, MINUS LEAD CABLE CONDUCTOR NEGATIVO	1	1	
9	98507-05010	SCREW TORNILLO DE CABEZA CON PLANA	1	1	
10	92907-05600	WASHER, PLATE ARANDELA	1	1	
11	3AY-H2501-V0	MAIN SWITCH STEERING LOCK LLAVE DE IGNICION COMPLT	1	1	
12	2JH-82552-V0	.CAP, SWITCH .TAPA DE INTERRUPTOR	1	1	
13	91317-06012	BOLT PERNO	2	2	
14	4ST-H2530-00	STOP SWITCH ASSY INTERRUPTOR DE PARADA COMPLETO	1	1	
15	4ST-H2590-00	WIRE HARNESS ASSY CONJUNTO DE CABLES	1	1	
16	3AY-H3936-00	BAND, SWITCH CORD BANDA DE CABLE DE INTERRUPTOR	2	2	
17	3AY-H3936-10	BAND, SWITCH CORD BANDA DE CABLE DE INTERRUPTOR	3	3	
18	3KA-H2150-01	FUSE HOLDER ASSY PORTA-FUSIBLES COMPLETO	1	1	

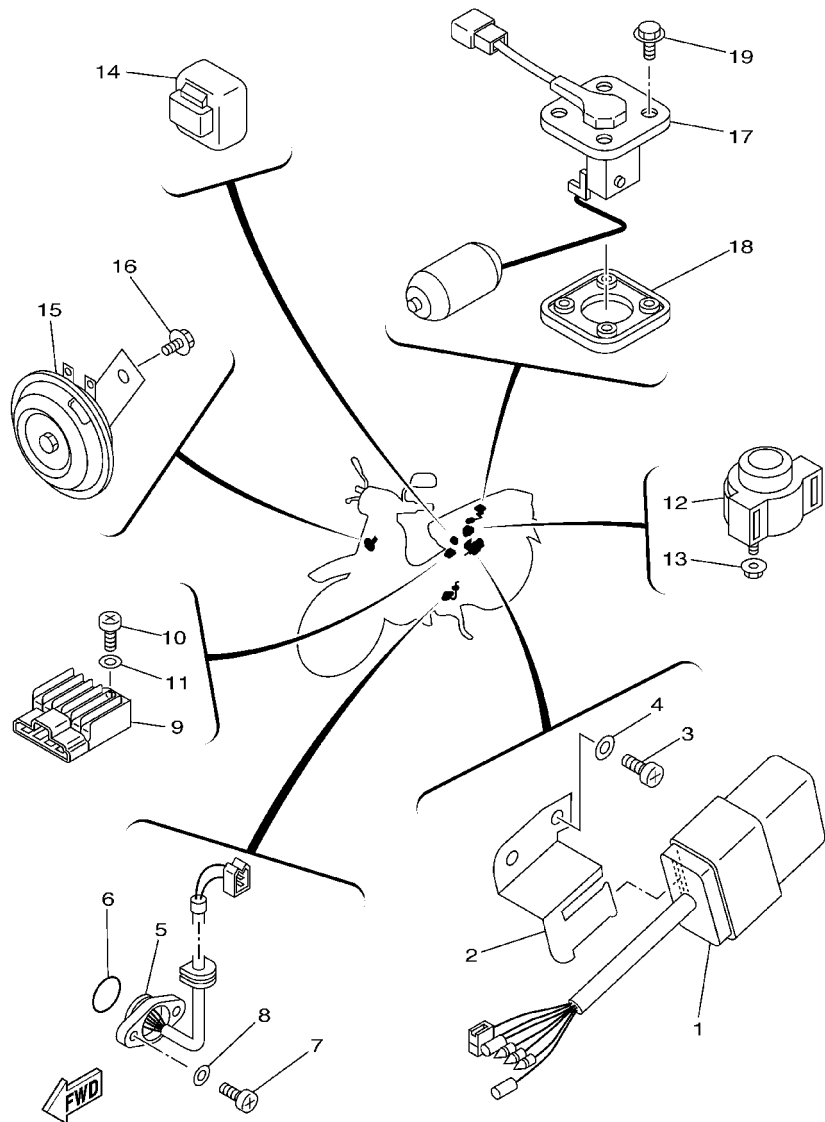

5AM3200-9400

FIG. 40 ELECTRICAL 2

EQUIPO ELECTRICO 2

REF. NO.	PART NO. CODIGO NO.	DESCRIPTION DESCRIPTION	5AM3	5AM4	REMARKS OBSERVACION
1	4ST-85540-00	C.D.I. UNIT ASSY UNIDAD C.D.I. COMPLETA	1	1	
2	4ST-F1274-00	BRACKET, C.D.I. UNIT SOPORTE DE UNIDAD C.D.I.	1	1	
3	98517-06020	SCREW, PAN HEAD TORNILLO DE CABEZA CON PLANA	1	1	
4	92907-06600	WASHER, PLATE ARANDELA	1	1	
5	4ST-82540-00	NEUTRAL SWITCH ASSY INTERRUPTOR NEUTRAL COMPL.	1	1	
6	93210-20573	O-RING JUNTA TORICA	1	1	
7	98507-05016	SCREW TORNILLO DE CABEZA CON PLANA	2	2	
8	92907-05600	WASHER, PLATE ARANDELA	2	2	
9	3KA-H1960-00	RECTIFIER & REGULATOR ASSY RECTIFICADOR Y REGULADOR	1	1	
10	98507-06016	SCREW TORNILLO DE CABEZA CON PLANA	1	1	
11	92907-06600	WASHER, PLATE ARANDELA	1	1	
12	4ST-H1940-00	STARTER RELAY ASSY CONJUNTO ARRANCADOR RELEVO	1	1	
13	95707-06500	NUT, FLANGE TUERCA DE BRIDA	2	2	
14	3WE-H3350-00	FLASHER RELAY ASSY RELE DE DESTELLADOR COMPL.	1	1	
15	3AY-H3371-V0	HORN BOCINA	1	1	
16	95817-06010	BOLT, FLANGE TUERCA DE REBORDE	1	1	
17	2JG-85752-00	SENDER UNIT ASSY, FUEL METER UNIDAD TRANSM. MED.COMBUST.	1	1	
18	5G3-85753-00	GASKET, SENDER UNIT EMPAQUE DE UNIDAD TRANSMISORA	1	1	
19	90119-05071	BOLT, WITH WASHER TORNILLO CON ARANDELA	4	4	

NUMERICAL INDEX  
INDICE NUMERICO

PART NO. CODIGO NO.	REF. NO.	PART NO. CODIGO NO.	REF. NO.	PART NO. CODIGO NO.	REF. NO.	PART NO. CODIGO NO.	REF. NO.	PART NO. CODIGO NO.	REF. NO.	PART NO. CODIGO NO.	REF. NO.
4ST-E1102-00	1-1	1EG-E5618-00	11-13	3XA-F174X-01	19-15	2JG-F3152-00	22-20	4ST-F5118-00	25-11	4ST-F7111-00-33	30-1
4ST-E111F-00	4-5	4ST-E5620-00	11-12	3XA-F174Y-00	19-32	1T8-F3156-00	22-15	3AY-F5181-01-91	25-13	3XA-F7112-01-91	30-2
4ST-E1161-00	1-5	4ST-E5664-00-92	11-10	5AM-F1740-00-33	19-24		22-29	4ST-F5183-00	25-10	4ST-F7114-00	8-5
4ST-E1162-00	1-21	4ST-E5676-00-92	11-8	5AM-F1740-10-33	19-24	2JG-F3157-00	22-7	23T-F5304-01	27-23	3AY-F7115-00-91	30-3
4ST-E1166-00	9-5	4ST-E8111-00-93	16-23	5AM-F1740-20-MW19	19-24		22-21	23T-F5311-00-33	27-1	4ST-F7211-00-93	30-6
4ST-E1181-00	1-14	4ST-F1110-00-33	17-1	5AM-F1740-30-21	19-24	509-F3158-L0	22-11	23T-F5311-10-WN	27-1	4ST-F7231-00-91	30-9
4ST-E1185-00	1-6	5AM-F1110-00-33	17-1	3XA-F1741-00-MW19	19-25		22-25	4ST-F5316-00	27-5	3XA-F7235-00	30-8
4ST-E1186-00	1-9	4ST-F117F-00	17-6	3XA-F1741-00-21	19-25	3SB-F3170-00	22-5	23T-F5321-01-33	27-7	4ST-F7311-00-33	30-15
4ST-E1310-00	1-17	4ST-F117G-00	17-10	3XA-F1741-00-33	19-25		22-19	23T-F5321-11-WN	27-7	4ST-F7411-00-33	30-19
4ST-E1351-01	1-19	4ST-F117N-00	17-12	4ST-F1783-00	19-35	278-F3181-50	22-13	4ST-F533A-00	27-14	2ET-F7413-00	30-21
4ST-E1400-03	2-1	4ST-F1274-00	40-2	5AM-F1784-00	24-22		22-27	23T-F5330-00	27-8	3XA-F7430-00	30-22
4ST-E1412-00	2-2	4ST-F139R-00	17-5	4ST-F2110-00-WN	20-1	4ST-F331A-00-33	21-22	3AY-F5355-00-91	27-11	3XA-F7433-00	30-23
4ST-E1422-00	2-6	4ST-F139X-00	17-7	3AY-F2141-01	20-4	4NS-F331E-01	22-33	23T-F5364-00	27-6		30-27
50M-E1610-00	2-13	3XA-F1398-00	24-20	4ST-F2151-00	20-3	3YR-F3340-00	22-30	37J-F5366-01	27-15	3XA-F7440-00	30-26
4ST-E1631-00	2-10	3XA-F1511-00-MW18	18-1	4ST-F2210-00	20-13	3YR-F3346-00	22-31	3AY-F5371-00-91	27-41	3XA-F7452-00-WN	30-30
4ST-E1635-00	2-10	3XA-F1511-00-21	18-1	4ST-F2310-00-33	20-7	4ST-F3391-00-MW21	12-12	3AY-F5381-01-91	27-28	3XA-F7462-00-WN	30-31
4ST-E1636-00	2-10	3XA-F1511-00-33	18-1	4ST-F2310-10-WN	20-7	4ST-F3391-00-21	21-12	2R2-F5388-00-91	27-34	4ST-F8100-00	17-13
4ST-E1637-00	2-10	4ST-F1518-00	18-6	4ST-F2315-00	20-12	4ST-F3391-00-33	21-12	2R2-F5389-00-91	27-35	4ST-F8311-00	31-1
4ST-E1638-00	2-10	4ST-F160E-00	18-19	5AM-F3100-00	22-1	3AY-F3416-00-91	21-6	4ST-F5412-00	27-20	4ST-F8311-10	31-1
4ST-E2170-01	4-1	3XA-F1611-00	18-7	5AM-F3100-10	22-1	4ST-F3461-00-92	21-19	4ST-F5437-00	27-19	4ST-F8311-20	31-1
4ST-E2176-00	4-8	4ST-F1629-00	18-16	5AM-F3102-00	22-2	4ST-F4110-00-33	23-1	4US-F580U-00	26-3	4ST-F8312-00	31-7
4ST-E2213-00	4-19	4ST-F1638-00	18-18	5AM-F3102-10	22-2	3XA-F4311-00	23-10	4NS-F582U-00	26-1	4ST-F8312-10	31-7
4ST-E3329-00	5-6	3AY-F1685-00-33	18-13	5AM-F3103-00	22-16	4ST-F4312-00	23-11	4US-F5872-00	29-1	4ST-F8312-20	31-7
4ST-E3411-00	5-10	3XA-F171E-00-MW19	31-1	5AM-F3103-10	22-16	4ST-F4313-00	23-12	4NS-F5886-00-90	21-23	4ST-F8321-00	31-12
4ST-E4197-00	7-25	3XA-F171E-00-21	19-31	2JG-F3110-00	22-4	5AM-F461A-00	23-17	3AY-F6113-00	28-5	4ST-F8322-00	31-17
4ST-E4411-00	6-7	3XA-F171E-00-33	19-31		22-18	23T-F4610-V0	23-17	3XA-F6129-00	28-22	4ST-F834V-00	31-28
4ST-E4412-00	6-9	3XA-F1711-00-MW19	1-1	2JG-F3111-00	22-12	4ST-F470F-00	24-2	4ST-F6129-00	28-6	3XA-F836T-00	31-29
4ST-E4423-00	6-12	3XA-F1711-00-21	19-1		22-26	5AM-F470F-00	24-2	3XA-F6210-00-91	28-1	5AM-F8368-00	31-2
4ST-E443E-00	6-17	3XA-F1711-00-33	19-1	3XA-F3113-00	21-25	3XA-F472E-00	24-6	4NS-F6213-00-MW28	7	5AM-F8368-10	31-2
4ST-E4433-00	6-13	5AM-F172W-00	19-36	3XA-F3122-00-MW21	8	3RS-F4724-00	24-5	4NS-F6213-00-21	28-7	5AM-F8368-20	31-2
4ST-E4451-01	6-8	3XA-F1721-00-MW19	6	3XA-F3122-00-21	21-8	3XA-F4726-00	24-7	4NS-F6213-00-33	28-7	5AM-F8368-30	31-2
4ST-E4452-00	6-11	3XA-F1721-00-21	19-6	3XA-F3122-00-33	21-8	3XA-F4728-00	24-12	3XA-F6215-00-MW28	9	5AM-F8380-00-33	31-18
4ST-E4453-00	6-10	3XA-F1721-00-33	19-6	4NS-F3126-00-33	22-3	4ST-F4730-00	24-1	3XA-F6215-00-21	28-9	5AM-F8380-10-33	31-18
4ST-E4472-01	6-14	5AM-F173E-00	19-13	4NS-F3126-10-WN22	3	5AM-F4730-00	24-1	3XA-F6215-00-33	28-9	5AM-F8380-20-MW31	18
4ST-E4613-00	8-8	5AM-F173E-10	19-13	3XA-F3132-00-MW21	10	23T-F4741-01	24-3	4US-F6219-00	28-26	5AM-F8380-30-21	31-18
4ST-E4628-00-93	8-2	5AM-F173E-20	19-13	3XA-F3132-00-21	21-10	3AY-F4742-00	24-17	3XA-F622F-00	19-14	4ST-F8385-00-MW31	19
4ST-E4711-00-93	8-1	5AM-F173E-30	19-13	3XA-F3132-00-33	21-10	3XA-F4744-00	24-8		19-27	4ST-F8385-00-21	31-19
4ST-E4781-00-WN	8-6	5AM-F173F-00	19-26	4US-F3136-00	22-17	3AY-F4763-00	24-4		28-8	4ST-F8385-00-33	31-19
4ST-E5113-00	10-11	5AM-F173F-10	19-26	4US-F3136-10-WN22	17	3XA-F4773-00-33	24-16	4ST-F6240-00	28-15	5AM-F8390-00-33	31-22
4ST-E5150-01	9-1	5AM-F173F-20	19-26	4ST-F3141-00	22-10	3AY-F4780-V0	24-14	3XA-F6241-00	28-17	5AM-F8390-10-33	31-22
4ST-E5362-00	10-19	5AM-F173F-30	19-26		22-24	3AY-F4796-00	24-19	3XA-F6242-00	28-16	5AM-F8390-20-MW31	22
4ST-E5371-00	9-2	5AM-F1730-00-33	19-11	2JG-F3144-00	22-9	5AM-F4796-00	18-24	3XA-F6280-01	28-18	5AM-F8390-30-21	31-22
4ST-E5411-00-WN10	1	5AM-F1730-10-33	19-11		22-23	5AM-F4810-00-93	24-21	3FS-F629T-00	28-20	5AM-F8391-00	31-20
4ST-E5418-00-WN10	12	5AM-F1730-20-MW19	11	2JG-F3145-00	22-14	5AM-F4846-00	18-21	3XA-F6290-01	28-19	5AM-F8391-10	31-20
4ST-E5421-00-WN10	14	5AM-F1730-30-21	19-11		22-28	4NS-F5104-00	25-5	4ST-F6311-00	28-23	5AM-F8391-20	31-20
4ST-E5436-00	10-22	3XA-F1731-00-MW19	12	2JG-F3147-00	22-8	4NS-F5111-00-33	25-1	3XA-F6326-00	28-21	5AM-F8391-30	31-20
4ST-E5451-00	10-2	3XA-F1731-00-21	19-12		22-22	4NS-F5111-10-WN25	1	4ST-F6331-00	28-25	5AM-F8392-00	31-24
4ST-E5461-00	10-15	3XA-F1731-00-33	19-12	2JG-F3152-00	22-6	4ST-F5116-00	25-2	4ST-F6393-00	28-24	5AM-F8392-10	31-24

NUMERICAL INDEX  
INDICE NUMERICO

PART NO. CODIGO NO.	REF. NO.	PART NO. CODIGO NO.	REF. NO.	PART NO. CODIGO NO.	REF. NO.	PART NO. CODIGO NO.	REF. NO.	PART NO. CODIGO NO.	REF. NO.	PART NO. CODIGO NO.	REF. NO.
5AM-F8392-20	31-24	3XA-H4710-00	37-1	4GL-14103-00	7-21	4ST-17231-00	14-14	4ST-81801-00	33-2	90159-06181	31-27
5AM-F8392-30	31-24	3XA-H4714-00	37-2	5DW-14104-00	7-22	4ST-17241-00	14-13	4ST-81826-00	33-3	90167-04033	28-10
4ST-F8395-00-MW31	23	3XA-H4721-00	37-7	4NM-14112-30	7-18	4ST-17402-01	14-10	4ST-81828-00	33-6	90167-05025	19-34
4ST-F8395-00-21	31-23	4ST-H5510-00	32-2	3XG-14133-00	7-4	4ST-17411-00	14-1	4ST-81861-00	33-4	90170-05302	3-10
4ST-F8395-00-33	31-23	3RW-W0041-02	29-5	127-14135-00	7-13	4ST-18101-01	16-1	4BP-82370-00	39-3	90170-18165	27-33
4ST-F8435-00	31-21	4US-W0045-00	26-8	4GL-14141-15	7-17	4GL-18120-01	15-4	4ST-82540-00	40-5	90175-06013	30-12
	31-25	4ES-W0047-10	26-5	3KD-14142-15	7-19	4GL-18140-00	16-8	2JH-82552-V0	39-12	90176-08026	1-12
4ST-H131X-00	32-4	51L-W0048-00	26-10	18A-14143-18	7-16	4GL-18152-00	16-2	3XA-83311-00	37-3	90179-08168	27-22
4ST-H1800-00	33-1	4TT-W0057-00	26-4	241-14147-00	7-11	4GL-1817A-00	16-19	3AY-83517-V0	35-4	90179-12588	32-8
4ST-H183G-00	33-5	90340-14810-WN	10-7	7LG-14150-11	7-23	4GL-18172-00	16-15	5R0-83517-V0	35-3	90179-12659	13-11
4ST-H1940-00	40-12	90340-32812-WN	10-9	802-14161-00	7-15	4GL-18179-00	16-13	2XF-83781-V0	35-5	90179-14469	13-23
3KA-H1960-00	40-9	90501-10245-91	30-10	132-14173-00	7-24	4GL-18181-00	16-14	4ST-83941-00	38-3	90179-25033	21-7
3AY-H2110-00	39-4	90501-205E8-91	27-44	4GL-14185-00	7-3	4GL-18186-00	16-20	3XA-8472F-00	37-4	90183-04005	21-14
3AY-H2110-10	39-4	4ST-11134-11	1-2	353-14186-00	7-10	4ST-18511-00	15-6	4ST-85540-00	40-1	90183-05042	19-19
3AY-H2115-00	39-5	4ST-11500-03	2-14	12R-14191-00	7-6	4ST-18512-00	15-7	4ST-85550-02	32-1		19-33
4ST-H2116-00	39-8	4ST-11536-00	2-7	4NM-14198-00	7-14	4ST-18531-00	15-5	4GU-85595-00	32-5	90183-06059	18-22
4ST-H2131-00	39-6	50M-11604-00	2-13	4GL-14239-00	7-2	55K-18531-00	16-18	2JG-85752-00	40-17	90185-10091	25-14
3KA-H2150-01	39-18	50M-11606-00	2-13	4GL-14348-00	7-9	4ST-18540-01	15-1	5G3-85753-00	40-18	90185-10154	21-21
4ST-H2310-00	39-1	50M-11610-20	2-13	4GL-14565-00	7-5	4BA-18542-00	15-2	90101-06278	27-12	90185-12046	20-5
3AY-H2501-V0	39-11	50M-11610-40	2-13	22F-14651-00	1-4	5H9-21376-00	17-15	90101-08590	4-10		27-29
4ST-H2530-00	39-14	22K-11633-01	2-11	4BD-14766-00	8-3	29N-21653-00	17-14	90101-08672	27-21	90201-061A5	27-37
4ST-H2590-00	39-15	4ST-11651-00	2-5	4ST-1490J-00	7-20	2JG-2171L-00	19-5	90105-08024	17-2	90201-063J2	37-10
3XA-H3310-00	34-1	4GL-11681-00	2-3	4GL-15316-00	9-4	2JG-2171M-10	19-10	90105-10036	21-20	90201-06380	17-17
3XA-H3311-00	34-3	4GL-12111-01	3-1	4ST-15512-00	12-1	307-22123-00	20-2	90105-10638	26-11	90201-064K6	23-8
	34-7	4GL-12114-00	3-4	4ST-15524-00	12-3	4ST-23108-00	21-13	90105-10778	20-17	90201-065F3	36-7
3XA-H3312-00	34-2	3UH-12117-00	3-6	3AY-15580-01	12-5	56J-23398-00	21-18	90109-065E0	24-10	90201-06557	18-11
3XA-H3320-01	34-5	1WG-12118-00	3-5	3AY-15583-00	12-6		31-26	90109-06577	38-10		31-5
3XA-H3322-00	34-6	4SV-12119-00	3-3	4ST-15641-00	11-2	156-23411-00	22-32	90109-066F1	30-24		31-10
3XA-H3332-00	37-5	4GL-12121-00	3-2	296-15644-00	11-6	22F-23411-01	21-4		30-28	90201-07641	5-5
3XA-H3342-00	37-6	3GM-12126-00	3-7		12-4	156-23412-00	21-1	90109-08034	30-16	90201-08326	4-9
3WE-H3350-00	40-14	50M-12151-00	3-8	4ST-15660-00	11-1	22F-23412-01	21-3	90109-081F0	26-2	90201-085E6	23-9
3AY-H3371-V0	40-15	22F-12156-00	3-11	296-15671-00	11-4	2JG-24500-01	23-14	90109-08183	27-42	90201-086P8	17-3
4ST-H3509-00	35-2	22F-12159-00	3-9	4ST-16150-00	13-13	2JG-24514-00	23-2	90116-08597	9-11	90201-08609	1-11
4ST-H3510-00	35-1	4ST-12171-01	4-2	3YR-16321-00	13-16	3PP-25190-01	25-16	90119-05001	13-19	90201-08612	28-4
3XA-H353K-00	35-6	4ST-12210-00	4-15	2JG-16324-00	13-15	4GL-25351-00	27-10	90119-05071	40-19	90201-087F0	27-45
4NS-H3550-00	35-8	4ST-12216-00	4-18	2JG-16351-01	13-17	167-25387-00	27-16	90119-06044	18-8	90201-101J1	25-15
4US-H3922-00	38-9	4ST-12223-00	4-17	2JG-16356-00	13-25	3YR-25852-00	29-7		18-17	90201-10118	29-3
3AY-H3936-00	39-16	4ST-12228-00	4-16	4ST-16357-00	13-24	3YR-25854-00	29-6		24-9	90201-106F2	20-16
3AY-H3936-10	39-17	4ST-12231-00	4-12	2JG-16371-00	13-14	3YK-25867-00	29-9	90146-06011	18-25	90201-10774	13-26
4ST-H3973-00	38-1	4ST-12241-00	4-13	4GL-16512-00	13-4	3YK-25870-02	29-4	90149-06131	38-12	90201-12166	14-7
3XA-H3975-00	38-7	4GL-13300-00	5-1	4ST-16586-00	13-5	4TT-25914-00	26-6	90149-06184	17-8	90201-122H1	13-10
4US-H3980-00	38-15	4ST-13324-00	5-11	4ST-16611-00	13-2	4TT-25919-00	26-9	90155-06007	5-7	90201-126A7	16-17
3XA-H4120-00	36-3	46J-13325-00	5-2	4ST-16620-00	13-8	4TT-25937-00	26-7	90159-06064	24-15		20-15
3AY-H4140-V0	36-5	4GL-13451-01	5-12	4ST-16626-00	13-9	94414-17849-93	27-27	90159-06067	19-2	90201-126L0	16-10
3XA-H4310-00	36-1	4ST-13586-01	6-1	4ST-17121-00	14-6	94414-17888-93	25-9		19-7	90201-12688	27-30
3AY-H4314-00	36-2	4ST-13595-00	6-2	4ST-17131-00	14-2	90387-121U1-91	27-31	90159-06085	19-21	90201-15700	14-17
3XA-H4317-00-92	36-4	4GL-1410A-00	7-12	4ST-17141-00	14-3	90387-181U2-91	27-32		31-4	90201-167P7	13-3
3AY-H454E-00-91	21-24	4ST-14101-01	7-1	4ST-17211-00	14-15	4ST-81403-00	32-3		31-9	90201-174L9	13-20

NUMERICAL INDEX  
INDICE NUMERICO

PART NO. CODIGO NO.	REF. NO.	PART NO. CODIGO NO.	REF. NO.	PART NO. CODIGO NO.	REF. NO.	PART NO. CODIGO NO.	REF. NO.	PART NO. CODIGO NO.	REF. NO.	PART NO. CODIGO NO.	REF. NO.
90201-20266	14 - 4	90480-13398	19 - 4	92907-06600	18 - 5	93430-12008	30 - 5	95827-06012	24 - 18	98517-06020	6 - 21
	14 - 11		19 - 9		21 - 17	93440-10153	1 - 3	95827-08016	10 - 23		40 - 3
90201-20276	16 - 6		19 - 23		21 - 28	93440-15012	14 - 18	95827-08025	24 - 23	98517-06025	10 - 13
90206-06090	36 - 8		31 - 6		23 - 16	93450-14088	2 - 12	97007-06016	17 - 16	98706-04012	29 - 8
90206-19027	11 - 5		31 - 11		30 - 14	93501-04011	21 - 2	97007-06020	31 - 16	98907-05010	21 - 15
90208-07052	5 - 4		31 - 15		40 - 4	93503-16003	21 - 5	97007-08016	28 - 2	98980-06008	8 - 4
90209-10131	38 - 2	90480-13426	37 - 12		40 - 11	93604-10011	16 - 12	97017-06016	39 - 2	99001-05600	5 - 3
90215-14321	13 - 22	90480-15397	21 - 26	92907-08100	27 - 43	93606-10227	13 - 6	97017-06020	18 - 4	99009-10400	15 - 8
90249-12008	30 - 11	90480-18276	37 - 9		28 - 3	93608-43157	12 - 2		18 - 9	99009-15400	11 - 11
90280-03017	2 - 9	90480-18476	23 - 6	92907-10200	28 - 12	93608-50149	16 - 7		18 - 14	99009-19400	11 - 7
90340-12059	5 - 8	90480-22800	18 - 23	92907-10600	20 - 18	93610-10174	12 - 7		23 - 3	99009-20400	16 - 5
90387-060G7	18 - 10	90501-02639	12 - 8		30 - 33	93822-15069	14 - 22	97017-06025	11 - 14	99530-10114	1 - 15
	19 - 3	90501-047H5	13 - 7	92907-12600	20 - 6	94122-17008	25 - 6	97017-06040	21 - 27		9 - 3
	19 - 8	90501-06022	15 - 3	92990-06600	20 - 11	94125-17012	27 - 24	97017-08020	16 - 24		9 - 7
	19 - 22	90501-10312	38 - 14	93101-10843	10 - 21	94222-17269	25 - 7	97017-10020	30 - 32		10 - 3
	31 - 3	90501-125E9	16 - 16	93102-12891	16 - 3		27 - 25	97027-06012	21 - 16		10 - 16
	31 - 8	90501-217J8	13 - 18	93102-15890	11 - 15	94325-17004	27 - 26		23 - 15		
90387-066M1	37 - 11	90506-18288	27 - 9	93102-20892	14 - 21	94332-17112	25 - 8		36 - 6		
90387-06681	17 - 11	90506-20041	30 - 7	93106-20816	25 - 3	94568-39098	27 - 39	97706-40016	34 - 4		
	18 - 15	90506-25047	30 - 18	93106-30817	27 - 17	94568-63084	4 - 11		34 - 8		
	18 - 20	90506-29054	30 - 4	93210-068F7	16 - 21	94668-37001	27 - 40	97706-40625	37 - 8		
	19 - 17	90508-263A8	11 - 9	93210-148F8	10 - 8	94700-00828	1 - 13	97707-40014	34 - 9		
	19 - 29	90508-265A1	16 - 9	93210-198F9	10 - 20	94700-00829	1 - 13	97707-50012	19 - 20		
	21 - 11	90508-295A0	16 - 4	93210-20573	40 - 6	95027-06025	22 - 34	97707-50014	28 - 13		
90387-068J7	6 - 20	90560-06201	31 - 14	93210-258G2	6 - 3	95027-06090	1 - 16	97707-50016	28 - 11		
	18 - 3	90560-16385	13 - 1	93210-328G3	10 - 10	95307-06600	27 - 13		35 - 7		
90387-0801M	23 - 7	90560-17328	13 - 21	93210-41041	27 - 4		27 - 36	98504-06010	20 - 10		
90387-10277	25 - 12	90560-17384	13 - 12	93210-448G4	1 - 10	95307-08700	27 - 46	98506-05035	38 - 6		
90387-1503D	14 - 16	91317-06012	4 - 6	93210-568G8	1 - 18	95307-10600	20 - 14	98506-05040	38 - 8		
90387-167L5	4 - 7		12 - 9	93210-638G6	1 - 7	95317-06700	6 - 6	98506-06008	38 - 4		
90401-10159	29 - 2		39 - 13	93306-001Y1	14 - 9	95317-08700	30 - 17	98507-04014	7 - 7		
90430-06014	4 - 20	91317-06014	32 - 7	93306-00210	4 - 4	95607-06100	24 - 11	98507-05010	20 - 8		
90430-12812	5 - 9	91317-06016	4 - 14	93306-00308	4 - 3		38 - 11		39 - 9		
90445-08170	39 - 7		4 - 21	93306-004X6	27 - 18		38 - 13	98507-05016	40 - 7		
90460-43053	6 - 19	91317-06025	6 - 4	93306-004Y8	27 - 18	95607-08200	17 - 4	98507-05030	6 - 15		
90465-08230	1 - 20		6 - 5	93306-202X8	14 - 19	95617-06100	30 - 25	98507-06016	1 - 8		
90467-08003	7 - 26		29 - 10	93306-20229	2 - 15		30 - 29		19 - 16		
90467-10008	23 - 13		32 - 6	93306-203X3	14 - 8	95707-06500	8 - 9		19 - 28		
90467-11106	6 - 18	91401-20015	30 - 13	93306-204Y7	14 - 20		16 - 22		21 - 9		
90467-13064	9 - 6	92901-06200	38 - 5	93306-20595	2 - 8		24 - 13		40 - 10		
90468-12007	27 - 47	92907-04100	7 - 8	93306-300Y6	25 - 4		37 - 13	98507-06040	9 - 10		
90468-23194	11 - 3	92907-05600	6 - 16	93306-301Y8	27 - 3		40 - 13		10 - 4		
90480-01321	28 - 14		20 - 9	93306-301Y9	27 - 2	95707-08500	8 - 7		10 - 17		
90480-10334	17 - 9		39 - 10	93310-326M9	2 - 4		23 - 5	98507-06050	10 - 5		
	19 - 18		40 - 8	93340-21209	16 - 11	95807-06014	31 - 13		10 - 18		
	19 - 30	92907-06100	23 - 4	93410-20038	14 - 5	95817-06010	40 - 16	98507-06060	9 - 9		
90480-12314	18 - 2		27 - 38		14 - 12	95817-08016	8 - 10	98507-06080	9 - 8		
90480-13398	18 - 12	92907-06600	6 - 22		14 - 23		30 - 20		10 - 6		