



**PARTS
CATALOGUE
CATALOGO
DE REPUESTOS**

T110C (40B8) ARGENTINA



1M40B-276SA

()

T110C
CATALOGO DE REPUESTOS
©2012 por Yamaha Motor Co., Ltd.
1ª edición, diciembre 2012
Todos los derechos reservados.
Toda reproducción o uso no autorizado
sin el consentimiento escrito de
Yamaha Motor Co., Ltd.
quedan expresamente prohibidos
Impreso en Japón.

T110C
PARTS CATALOGUE
©2012 by Yamaha Motor Co., Ltd.
1st edition, December 2012
All rights reserved.
Any reprinting or unauthorized use
without the written permission of
Yamaha Motor Co., Ltd.
is expressly prohibited.
Printed in Japan.

PROLOGO

Este catálogo de repuestos corresponde a las piezas para el o los modelos que figuran en la página de portada. Al formular el pedido de repuestos, se ruega citar este catálogo y especificar correctamente el número y el nombre de las piezas.

1. Las modificaciones y agregados que se hayan realizado después de la edición de este Catálogo de Repuestos, serán anunciados en las Informaciones de Recambios. Es recomendable que se hagan las correcciones necesarias en el Catálogo de Repuestos de acuerdo con las Informaciones de Recambios.

2. Abreviaciones

En este. Catálogo de Repuestos se emplean las siguientes abreviaciones.

“UR” Usar el número de partes especificado

“UN” Usar la cantidad necesaria

“AP” Piezas sustitutivas

“LM” Fabricación local (Hay que pedir los repuestos en las cercanías)

“F#” N° de bastidor (N° aplicable a la máquina)

“O/S” Sobredimensionado

3. La cantidad de componentes para el montaje

- Los componentes, suministrados como conjunto, se describen con un punto (.) que precede al nombre del parte como se indica a continuación.
- La numeración que aparece a la derecha de cada descripción indica la cantidad de partes por cada unidad de conjunto.

CODIGO N°	DESCRIPCION	CANT.	OBSERVACIONES
2F5-83310-60	ENSAMBLAJE DE LA LUZ	2	
115-83311-60	.BOMBILLA (6V-18W)	1	

4. Los colores de los componentes se indican como sigue en la columna de “OBSERVACIONES”.

CODIGO N°	DESCRIPCION	CANT.	OBSERVACIONES
2N4-24110-00-X5	COMP. DEL TANQUE	2	MXR
3J1-24240-10	.GRAFICO, DEL TANQUE	1	PARA MXR

5. Debe tenerse en cuenta que las ilustraciones sirven como guía para la búsqueda de los números de partes y no deben usarse para el montaje. Durante el montaje, se recomienda usar el manual de taller correspondiente.

6. EL asterisco (*) antes del número de referencia indica los elementos modificados después de la primera edición.

FOREWORD

This Parts Catalogue is related to the parts for the model(s) on the cover page. When you are ordering replacement parts, please refer to this Parts Catalogue and quote both part numbers and part names correctly.

1. Modifications or additions which have been made after the issue of the Parts Catalogue will be announced in the Parts News.

It is advisable that you make the necessary corrections to the Parts Catalogue according to the Parts News.

2. Abbreviations

The following abbreviations are used in this Parts Catalogue.

“UR” Use specified parts number.

“UN” Use as many as needed.

“AP” Alternate Parts

“LM” Locally Made (Parts need to be ordered locally)

“F#” Frame No. (Applicable machine No.)

“O/S” Over Size

3. The number of components for assembly

- Parts, which are to be supplied in an assembly, are listed with a dot (.) in front of the part name as shown below.
- The numeral appearing to the right of each component part indicates the quantity of parts for each assembly unit.

PART NO.	DESCRIPTION	Q'TY	REMARKS
2F5-83310-60	FRONT FLASHER LIGHT ASSY	2	
115-83311-60	.BULB (6V-18W)	1	

4. Applicable colours of graphics are represented in the “REMARKS” as shown below.

PART NO.	DESCRIPTION	Q'TY	REMARKS
2N4-24110-00-X5	FUEL TANK COMP.	2	MXR
3J1-24240-10	.GRAPHIC, FUEL TANK	1	FOR MXR

5. Note that the illustrations for reference in finding parts numbers are not to be used for assembling. When assembling, please use the applicable service manual.

6. The asterisk (*) before a reference number indicates modified items after the first edition.

PROLOGO

7. Números de serie

Nº de Serie del bastidor

Nº de Serie del motor

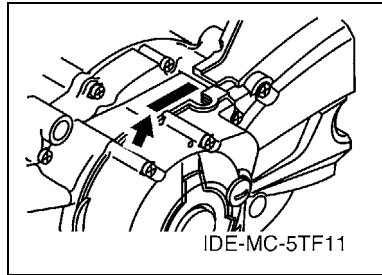
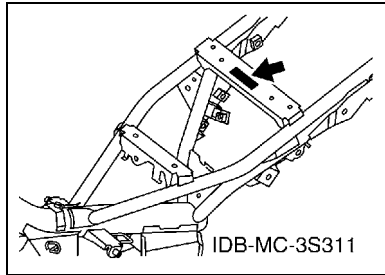

8. Códigos de color aplicables (El símbolo (*) muestra el color de modelo.)

Abreviatura	Nombre de color	Código de color
BS4	BLUISH SILVER 4	0820
CIS	CIRCUIT SILVER	00WN
DPBMC(*)	DEEP PURPLISH BLUE METALLIC C	0564
DRMK(*)	DEEP RED METALLIC K	0918
SMX(*)	BLACK METALLIC X	0903

9. Nº de serie inicial aplicable

Nº de Serie del bastidor

Nº de serie	Nombre de la columna de cantidades	Código de Modelo

Nº de Serie del motor

Nº de serie	Nombre de la columna de cantidades	Código de Modelo

FOREWORD

7. Applicable Serial No.

Frame Serial No.

Engine Serial No.

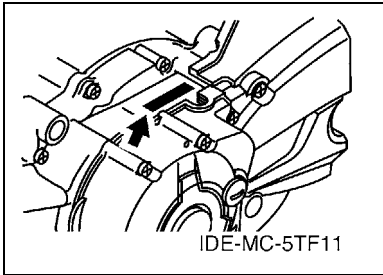
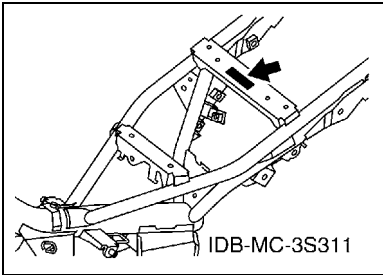

8. Applicable Colour Code (The (*) mark shows Model colour.)

Abbreviation	Colour Name	Colour Code
BS4	BLUISH SILVER 4	0820
CIS	CIRCUIT SILVER	00WN
DPBMC(*)	DEEP PURPLISH BLUE METALLIC C	0564
DRMK(*)	DEEP RED METALLIC K	0918
SMX(*)	BLACK METALLIC X	0903

9. Applicable Starting Serial No.

Frame Serial No.

Serial No.	Name Of Q'ty Column	Model Code

Engine Serial No.

Serial No.	Name Of Q'ty Column	Model Code

CONTENIDO

MOTOR

CULATA DE CILINDRO	1
CIGUENAL & PISTON	2
VALVULA	3
ARBOL DE LEVAS & CADENA	4
BOMBA DE ACEITE	5
ADMISION	6
CARBURADOR	7
DESCARGA	9
CARTER	10
CUBIERTA DE CARTER 1	11
ARRANQUE	12
EMBRAGUE DEL ARRANQUE	13
EMBRAGUE	14
TRANSMISION	16
LEVA DE CAMBIO & HORQUILLA	17
EJE DE CAMBIO & PEDAL	18

SHASIS

CUADRO	19
GUARDABARRO	20
CUBIERTA LATERAL	21
BRAZO TRASERO & SUSPENSION	22
DIRECCION	23
HORQUILLA DELANTERA	25
DEPOSITO DE COMBUSTIBLE	27
ASIENTO	28
RUEDA DELANTERA	29
CALIBRE FRENO DELANTERA	30
RUEDA TRASERA	31
MANILLAR & CABLE	33
CILINDRO MAESTRO DELANTERO	34
SOPORTE & APOYAPIE	35
PATA PROTEGIDA	37
GENERADOR	39
MOTOR DE ARRANQUE	40
LUZ DE DESTELLADOR	41
MEDIDOR	42
FARO DELANTERO	43
LUZ DE COLA	44
INTERRUPTOR DE MANILLAR&PALANC	45
EQUIPO ELECTRICO 1	46

EQUIPO ELECTRICO 2	47
--------------------------	----

INDICE

INDICE NUMERICO	48
-----------------------	----

CONTENTS

ENGINE

CYLINDER HEAD	1
CRANKSHAFT & PISTON	2
VALVE	3
CAMSHAFT & CHAIN	4
OIL PUMP	5
INTAKE	6
CARBURETOR	7
EXHAUST	9
CRANKCASE	10
CRANKCASE COVER 1	11
STARTER	12
STARTER CLUTCH	13
CLUTCH	14
TRANSMISSION	16
SHIFT CAM & FORK	17
SHIFT SHAFT	18

CHASSIS

FRAME	19
FENDER	20
SIDE COVER	21
REAR ARM & SUSPENSION	22
STEERING	23
FRONT FORK	25
FUEL TANK	27
SEAT	28
FRONT WHEEL	29
FRONT BRAKE CALIPER	30
REAR WHEEL	31
STEERING HANDLE & CABLE	33
FRONT MASTER CYLINDER	34
STAND & FOOTREST	35
LEG SHIELD	37
GENERATOR	39
STARTING MOTOR	40
FLASHER LIGHT	41
METER	42
HEADLIGHT	43
TAILLIGHT	44
HANDLE SWITCH & LEVER	45
ELECTRICAL 1	46

ELECTRICAL 2	47
--------------------	----

INDEX

NUMERICAL INDEX	48
-----------------------	----

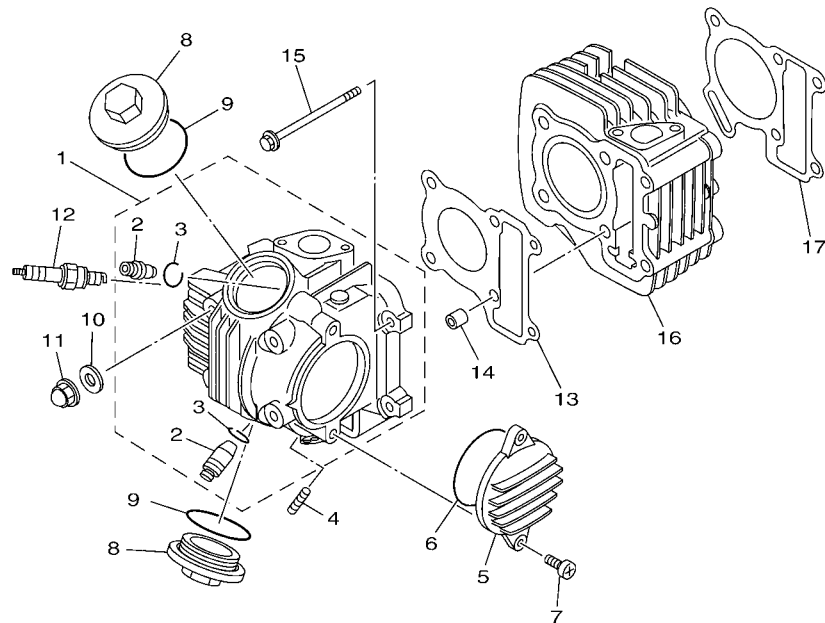

40B1516-G010

FIG. 1 CULATA DE CILINDRO

CYLINDER HEAD

REF. N°	CODIGO N° PART NO.	DESCRIPCION DESCRIPTION	40B8				OBSERVACIONES REMARKS
1	4S9-E1111-10	CULATA CILINDRO 1 HEAD, CYLINDER 1	1				
2	4ST-11134-11	.GUIA DE VALVULA 2 .GUIDE, VALVE 2	2				
3	93440-10153	.SEGURO .CIRCLIP	2				
4	90116-06820	ESPARRAGO BOLT, STUD	2				
5	4S9-E1185-00	CUBIERTA CULATA CIL.LAT.3 COVER, CYLINDER HEAD SIDE 3	1				
6	93210-62802	ANILLO O O-RING	1				
7	98502-06016	TORNILLO SCREW, PAN HEAD	2				
8	5WB-E1186-00	CUBIERTA CULATA CIL.LAT.2 COVER, CYLINDER HEAD SIDE 2	2				
9	93210-44807	ANILLO O O-RING	2				
10	90201-08827	ARANDELA PLANA WASHER, PLATE	4				
11	90176-08812	TUERCA CORONA NUT, CROWN	4				
12	94700-00869	BUJIA (NGK CR6HSA) PLUG SPARK (NGK CR6HSA)	1				
13	4S9-E1181-00	JUNTA, DE CULATA 1 GASKET, CYLINDER HEAD 1	1				
14	99530-10114	PASADOR, DE ESPIGA PIN, DOWEL	2				
15	95022-06090	PERNO, DE BRIDA BOLT, FLANGE	2				
16	4S9-E1310-00-B0	CILINDRO CYLINDER	1				
17	4S9-E1351-00	JUNTA, DE CILINDRO GASKET, CYLINDER	1				

FIG. 2 CIGUENAL & PISTON

CRANKSHAFT & PISTON

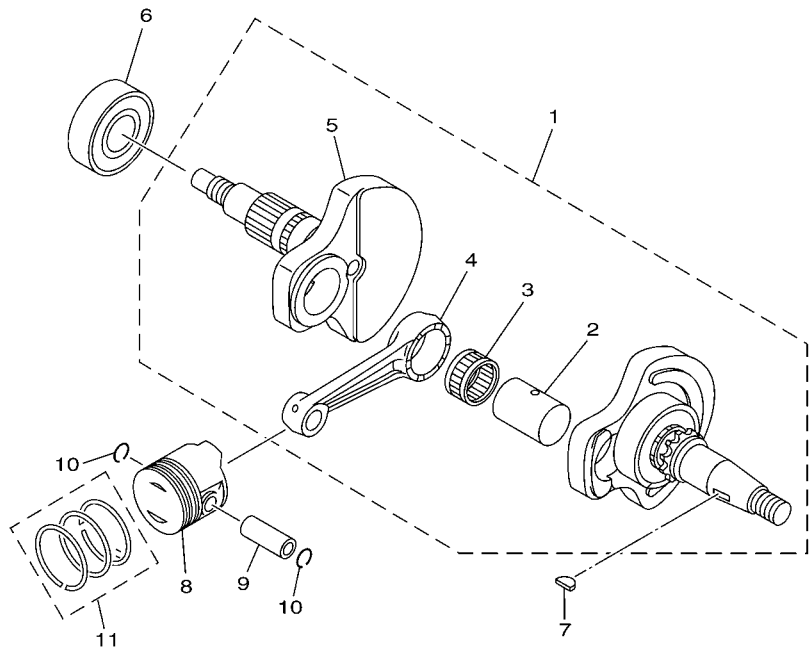

REF. Nº	CODIGO Nº PART NO.	DESCRIPCION DESCRIPTION	4088				OBSERVACIONES REMARKS
1	4S9-WE140-00	CIGUENAL COMPLETO CRANKSHAFT ASSY	1				
2	4S9-E1681-00	.PASADOR MANIVELA 1 .PIN, CRANK 1	1				
3	93310-526Y6	.COJINETE DE RODILLOS .BEARING	1				
4	4S9-E1651-00	.BIELA .ROD, CONNECTING	1				
5	4S9-E1422-00	.MANIVELA 2 .CRANK 2	1				
6	93306-205YP	COJINETE BEARING	1				
7	90280-03017	CUNA WOODRUFF KEY, WOODRUFF	1				
8	4S9-E1631-10-A0	PISTON (NORMA) PISTON (STD)	1				
9	5WB-E1633-00	PASADOR, PISTON PIN, PISTON	1				
10	93450-14088	SEGURO CIRCLIP	2				
11	4S9-E1603-20	JUEGO DE ANILLOS (NORMA) PISTON RING SET (STD)	1				

4S91415-F020

FIG. 3 VALVULA

VALVE

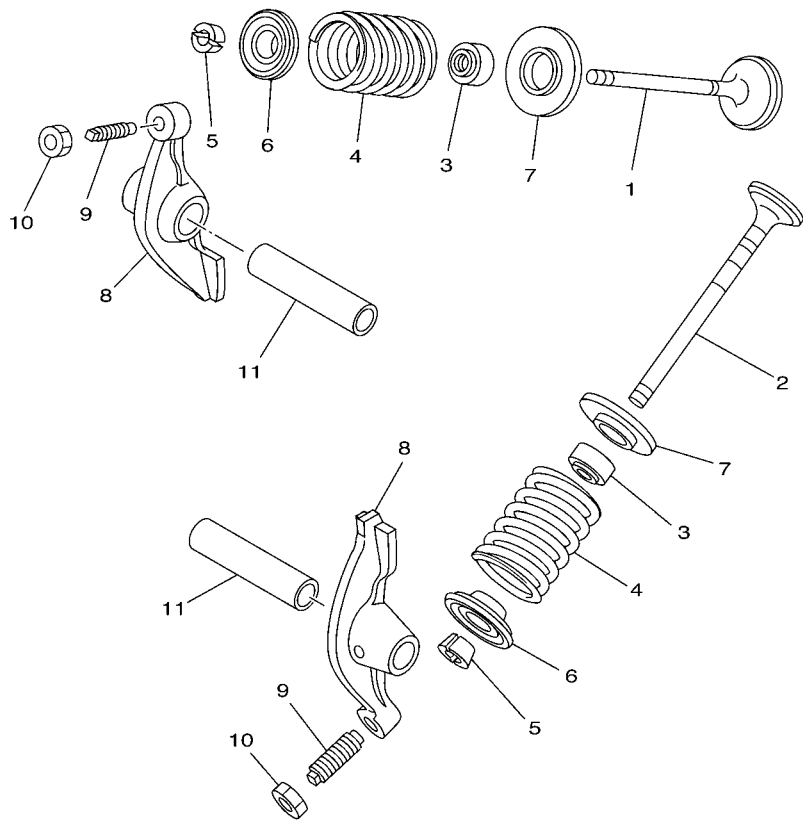

REF. N°	CODIGO Nº PART NO.	DESCRIPCION DESCRIPTION	4088				OBSERVACIONES REMARKS
1	4S9-E2111-00	VALVULA DE ADMISION VALVE, INTAKE	1				
2	4S9-E2121-00	VALVULA DE ESCAPE VALVE, EXHAUST	1				
3	4S9-E2119-00	SELLO DE ACEITE VALVULA SEAL, VALVE STEM	2				
4	4S9-E2114-00	RESORTE VALVULA EXTERIOR SPRING, VALVE OUTER	2				
5	4S9-E2118-00	SEGURO DE VALVULA LOCK, VALVE SPRING RETAINER	4				
6	4S9-E2117-00	RETEN RESORTE DE VALVULA RETAINER, VALVE SPRING	2				
7	4S9-E2126-00	ASIENTO RESORTE DE VALVULA2 SEAT, VALVE SPRING 2	2				
8	4S9-E2151-00	BRAZO DE BALANCIN DE VALVULA ARM, VALVE ROCKER	2				
9	5WB-E2159-00	TORNILLO DE AJUSTE DE VALVULA SCREW, VALVE ADJUSTING	2				
10	90170-05302	TUERCA NUT	2				
11	5WB-E2156-00	EJE DE BALANCIN SHAFT, ROCKER 2	2				

4ST1460-6030

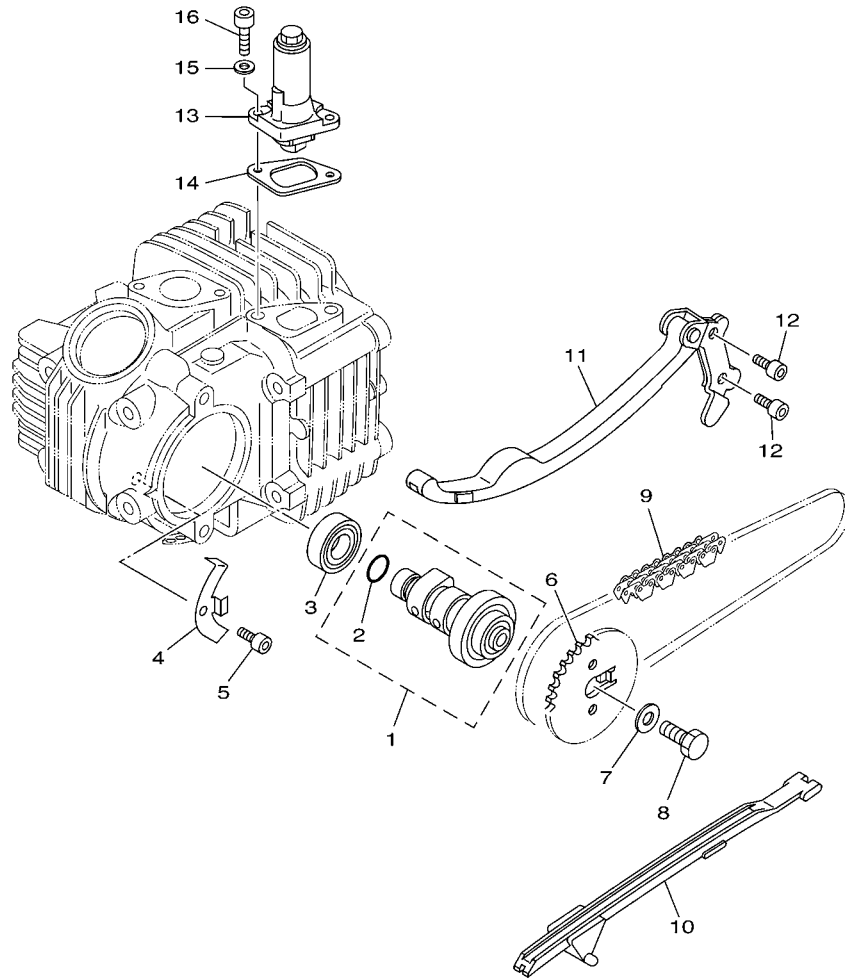

5TN3431-B041

FIG. 4 ARBOL DE LEVAS & CADENA CAMSHAFT & CHAIN

REF. Nº	CODIGO Nº PART NO.	DESCRIPCION DESCRIPTION	4088				OBSERVACIONES REMARKS
1	4S9-E2170-10	ARBOL DE LEVAS COMPLETO 1 CAMSHAFT ASSY 1	1				
2	93210-108B1	.ANILLO O .O-RING	1				
3	93306-002X9	COJINETE BEARING	1				
4	4S9-E111F-00	PLACA PLATE	1				
5	91312-06012	TORNILLO BOLT	1				
6	4S9-E2176-00	CATALINA DE CADENA SPROCKET, CAM CHAIN	1				
7	90201-08824	ARANDELA PLANA WASHER, PLATE	1				
8	90101-08820	TORNILLO BOLT	1				
9	94568-F2086	CADENA CHAIN	1				
10	4S9-E2231-00	TOPE DE GUIA 1 GUIDE, STOPPER 1	1				
11	4S9-E2241-00	TOPE DE GUIA 2 GUIDE, STOPPER 2	1				
12	91312-06016	TORNILLO BOLT	2				
13	5WB-E2210-00	TENSOR CADENA DE LEVA TENSIONER ASSY, CAM CHAIN	1				
14	5WB-E2213-10	EMPAQUE DE CAJA TENSOR GASKET, TENSIONER CASE	1				
15	90430-06817	JUNTA GASKET	2				
16	91312-06018	TORNILLO BOLT	2				

FIG. 5 BOMBA DE ACEITE

OIL PUMP

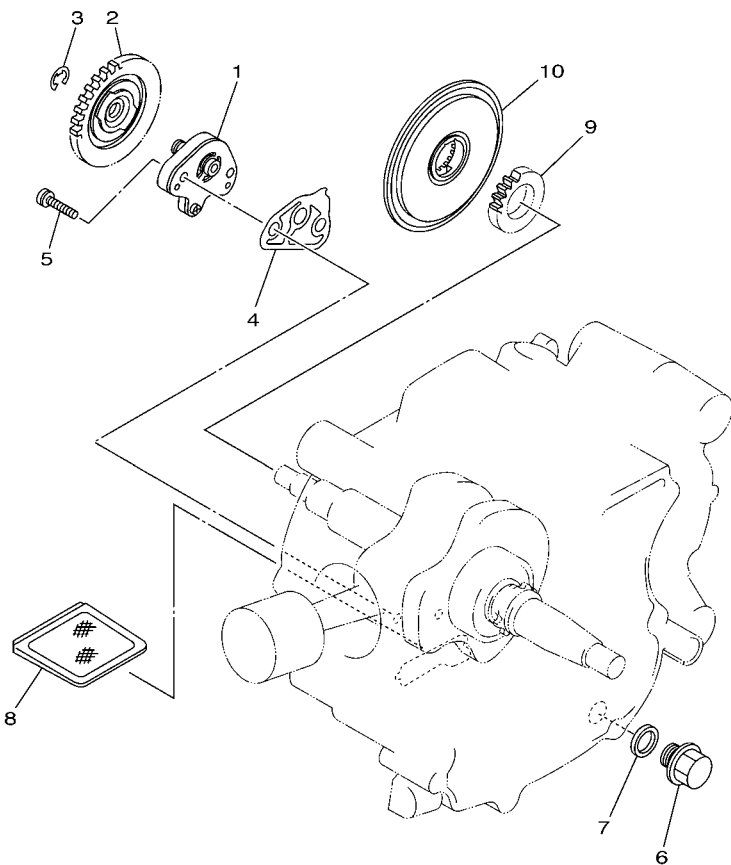

5TN1431-B050

REF. N°	CODIGO N° PART NO.	DESCRIPCION DESCRIPTION	4038				OBSERVACIONES REMARKS
1	4S9-E3104-00	SUBENSAMBLE BOMBA DE ACETE OIL PUMP SUB ASSY	1				
2	4S9-E3325-00	ENGRANAJE IMPULSOR DE BOMBA 1 GEAR, PUMP DRIVEN	1				
3	93430-05826	SEGURO CIRCLIP	1				
4	4S9-E3329-00	EMPAQUE TAPA DE BOMBA GASKET, PUMP COVER	1				
5	90155-06801	TORNILLO CABEZA PLANA RAN. SCREW, FLAT FILLISTER	2				
6	90340-12806	TORNILLO, DE DRENAJE PLUG, STRAIGHT SCREW	1				
7	90430-12227	JUNTA GASKET	1				
8	4S9-E3411-00	FILTRO DE ACEITE STRAINER, OIL	1				
9	4S9-E3324-00	ENGRANAJE TRACC. DE BOMBA GEAR, PUMP DRIVE	1				
10	4S9-E3451-00	FILTRE ROTATIVO FILTER, ROTARY	1				

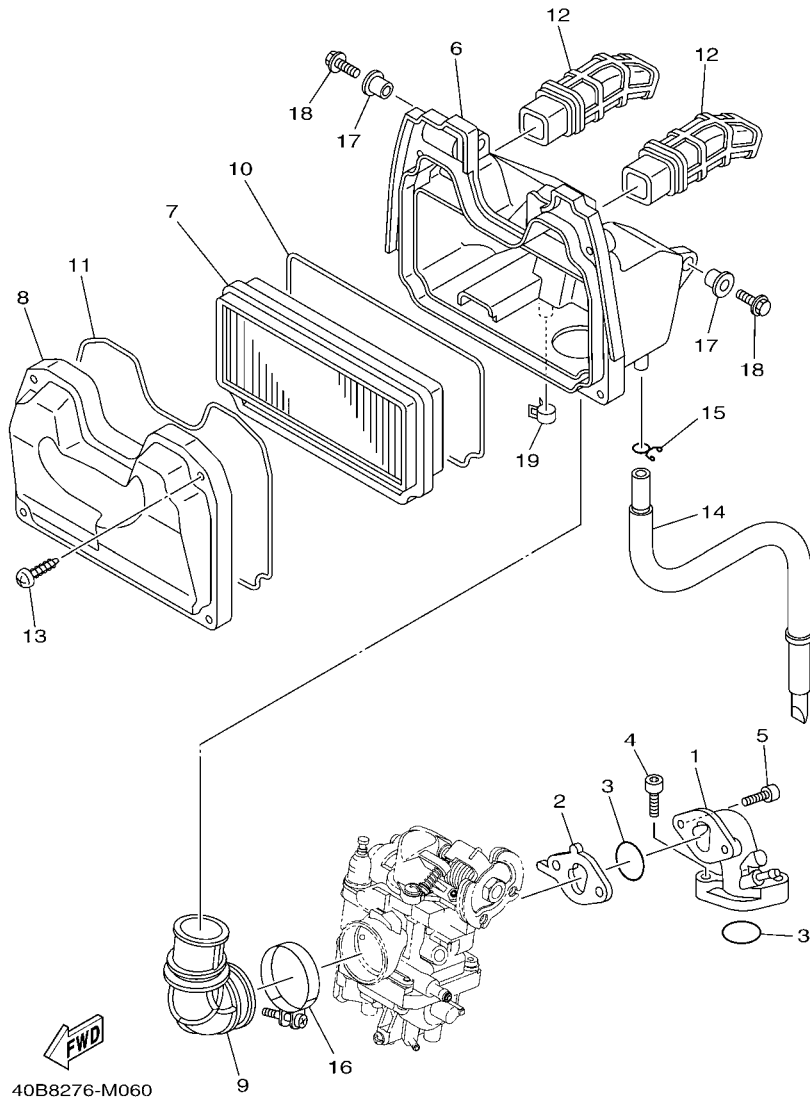

40B8276-M060

FIG. 6 ADMISION

INTAKE

REF. N°	CODIGO N° PART NO.	DESCRIPCION DESCRIPTION	40B8				OBSERVACIONES REMARKS
1	1DU-E3586-00	TOBERA DE CARBURADOR 1 JOINT, CARBURETOR 1	1				
2	4S9-E3595-00	TOBERA JOINT	1				
3	93210-25809	ANILLO O O-RING	2				
4	91312-06025	TORNILLO BOLT	2				
5	90110-06256	TORNILLO ALLEN BOLT, HEXAGON SOCKET HEAD	2				
6	4S9-E4411-10	CAJA FILTRO DEL AIRE 1 CASE, AIR CLEANER 1	1				
7	4S9-E4451-01	ELEMENTO DEL FILTRO DEL AIRE ELEMENT, AIR CLEANER	1				
8	4S9-E4412-00	TAPA CAJA DEL FILTRO 1 CAP, CLEANER CASE 1	1				
9	4S9-E4453-00	UNION DEL FILTRO DEL AIRE 1 JOINT, AIR CLEANER 1	1				
10	4S9-E4457-00	SELLO SEAL	1				
11	4S9-E4452-00	SELLO SEAL	1				
12	4S9-E4423-00	TUBO DE SUCCION 1 PIPE, SUCTION 1	2				
13	97702-50030	TORNILLO ROSCA HEMBRA SCREW, TAPPING	4				
14	40B-E443E-00	TUBO, DRENAJE PIPE, DRAIN	1				
15	90467-110A3	PRESILLA CLIP	1				
16	90450-43802	BRIDA, MANGUERA HOSE CLAMP ASSY	1				
17	90387-068K3	ESPACIADOR COLLAR	2				
18	95802-06020	TORNILLO DE REBORDE BOLT, FLANGE	2				
19	90467-13800	PRESILLA CLIP	1				

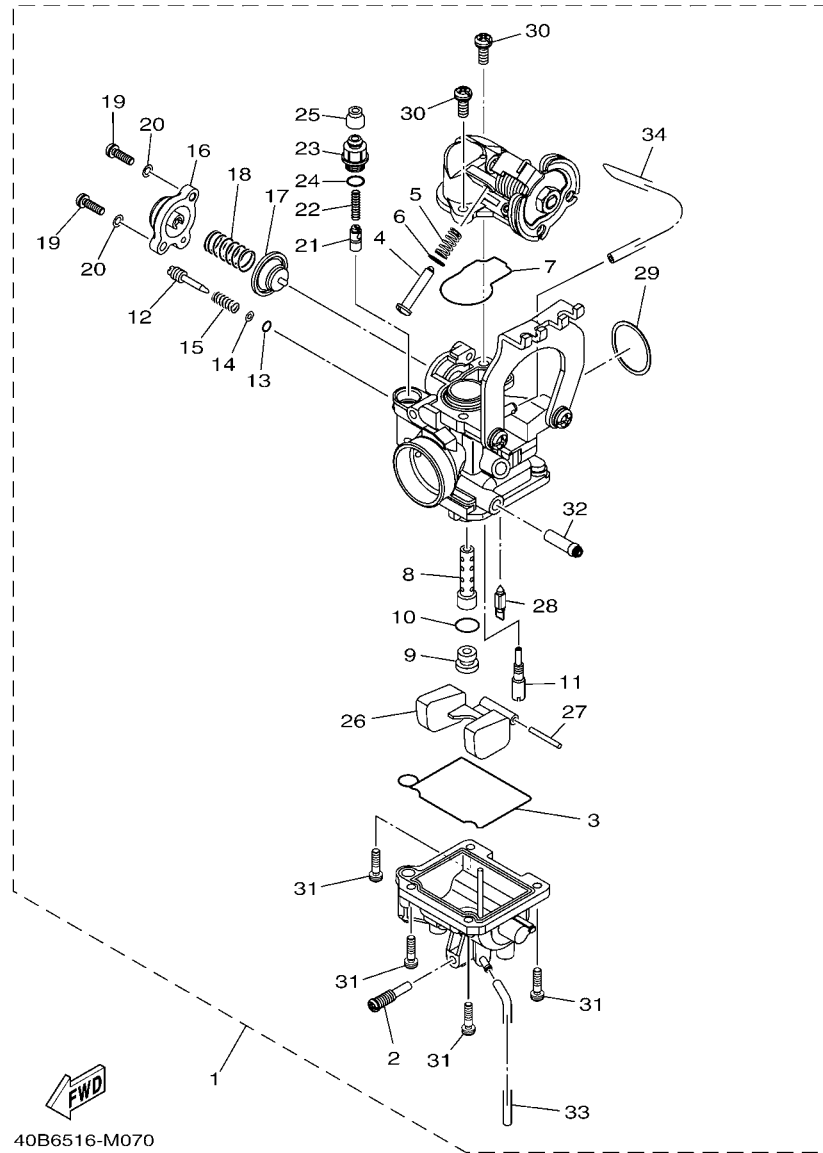

40B6516-M070

FIG. 7 CARBURADOR

CARBURETOR

REF. Nº	CODIGO Nº PART NO.	DESCRIPCION DESCRIPTION	4088				OBSERVACIONES REMARKS
1	40B-E4301-00	CARBURADOR COMPLETO 1 CARBURETOR ASSY 1	1				
2	1JD-E4306-00	.DRENAJE, TORNILLO .DRAIN, SCREW	1				
3	1JD-E4384-00	.EMPAQUE DE CAMARA DE BOIA .GASKET, FLOAT CHAMBER	1				
4	1JD-E4321-00	.TORNILLO DE OBTURADOR .SCREW, THROTTLE	1				
5	1JD-E4333-00	.RESORTE DE TOPE ACELERADOR .SPRING, THROTTLE STOP	1				
6	5WB-E4596-00	.ARANDELA .WASHER	1				
7	1JD-E4561-00	.ANILLO O .O-RING	1				
8	1JD-E4341-00	.BOQUILLA PRINCIPAL .NOZZLE, MAIN	1				
9	1JD-E4343-52	.INYECTOR PRINCIPAL (#104) .JET, MAIN (#104)	1				
10	360-24512-00	.EMPAQUE .GASKET	1				
11	1JD-E4342-68	.ESPREA DE PILOTO (#136) .JET, PILOT (#136)	1				
12	1JD-E4323-00	.TORNILLO DE AJUSTE DE AIRE .SCREW, AIR ADJUSTING	1				
13	5WB-E4147-00	.ANILLO O .O-RING	1				
14	5WB-E4962-00	.ARANDELA .WASHER	1				
15	4JP-E4134-00	.RESORTE AJUSTE DE VALVULA .SPRING, AIR ADJUSTING	1				
16	1JD-E4293-00	.CUBIERTA .COVER 1	1				
17	1JD-E4368-00	.DIAFRAGMA COMPLETO 1 .DIAPHRAGM ASSY 1	1				
18	1JD-E4589-00	.RESORTE .SPRING	1				
19	97601-04114	.TORNILLO CON RONDONA .SCREW, PAN HEAD WITH WASHER	2				
20	1JD-E4357-00	.ARANDELA .WASHER, PLAIN	2				
21	1JD-E4371-00	.EMBOLO DE ARRANQUE .PLUNGER, STARTER	1				
22	1JD-E4335-00	.RESORTE DE EMBOLO .SPRING, PLUNGER	1				
23	1JD-E4374-00	.TAPA DE EMBOLO .CAP, PLUNGER	1				
24	1JD-E4397-00	.ANILLO O .O-RING	1				
25	4FP-E4118-00	.TAPA .CAP	1				
26	1JD-E4385-00	.BOIA .FLOAT	1				
27	1JD-E4386-00	.PASADOR DE BOIA .PIN, FLOAT	1				

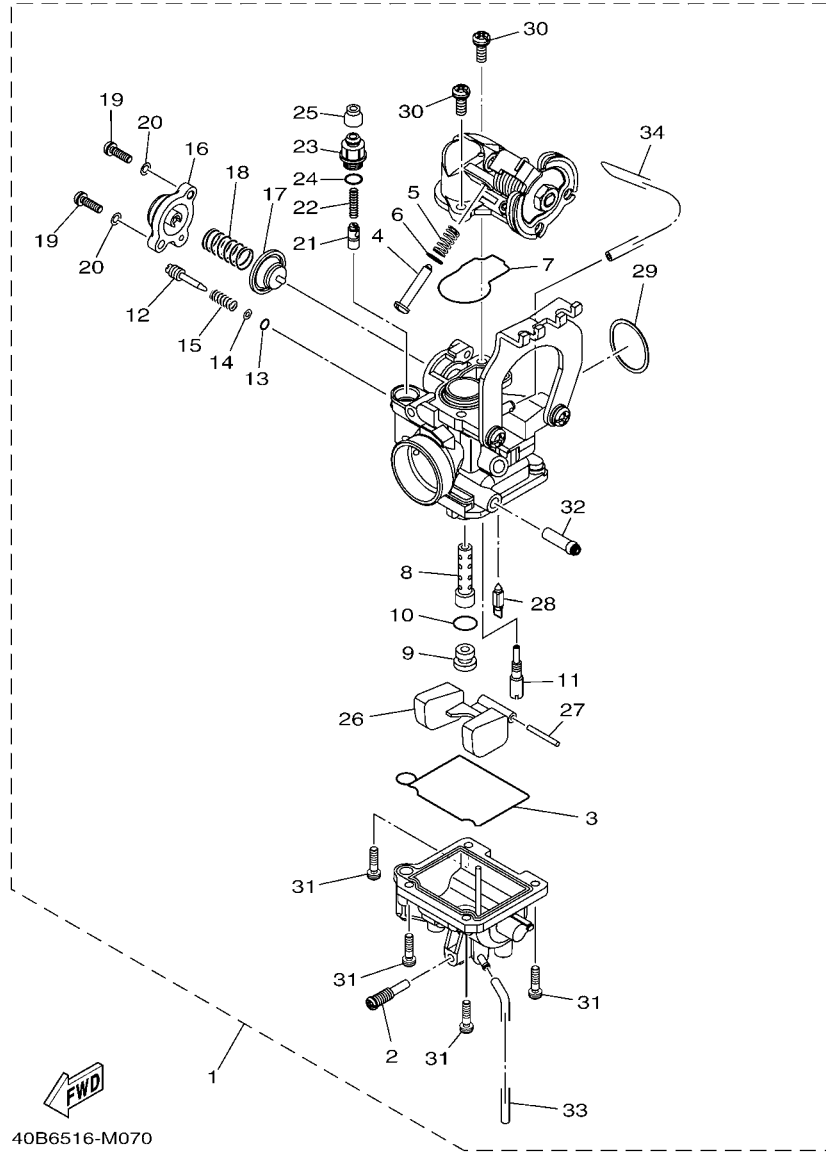

FIG. 7 CARBURADOR

CARBURETOR

REF. Nº	CODIGO Nº PART NO.	DESCRIPCION DESCRIPTION	40B6				OBSERVACIONES REMARKS
28	5AV-14390-00	.VALVULA DE AGUJA COMPLETA .NEEDLE VALVE ASSY	1				
29	85L-14147-00	.ANILLO O .O-RING	1				
30	1JD-E4325-00	.TORNILLO CABEZA REDONDA .SCREW, PAN HEAD	2				
31	97901-04116	.TORNILLO, CON ARANDELA .SCREW, WITH WASHER	4				
32	5AV-E445E-00	.FILTRO 1 .FILTER 1	1				
33	1JD-E4349-01	.TUBO .PIPE	1				
34	1JD-E4197-00	.TUBO RESPIRADERO .PIPE	1				

FIG. 8 DESCARGA

EXHAUST

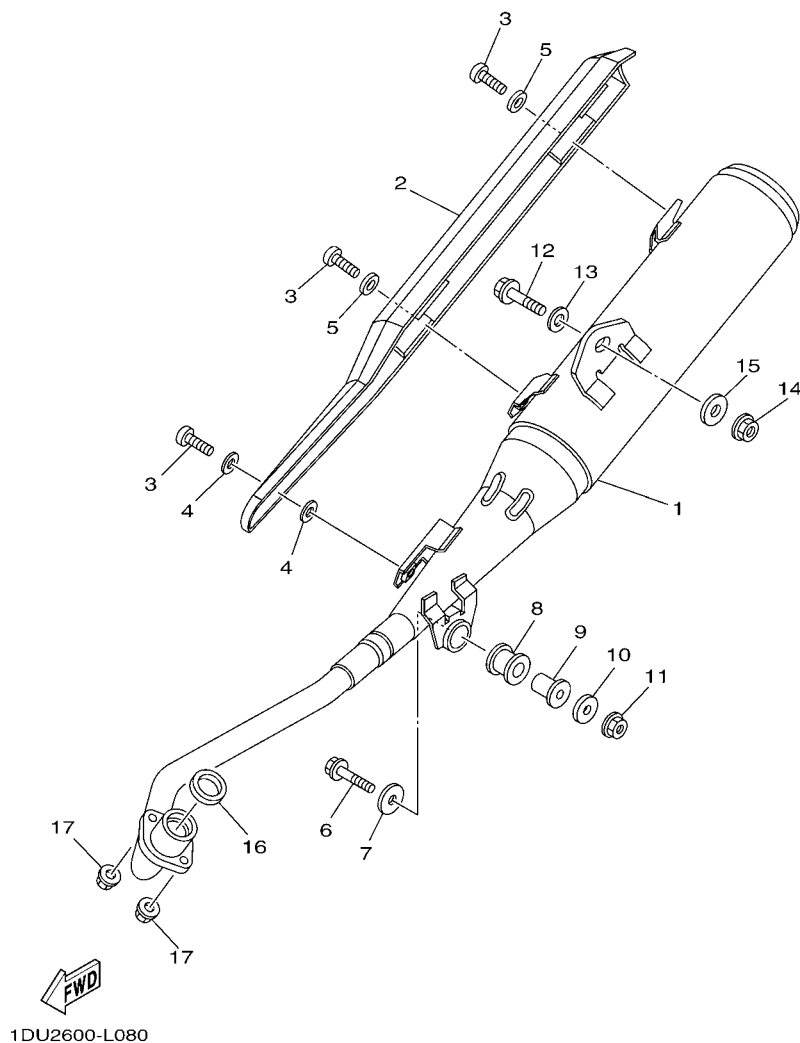

REF. Nº	CODIGO Nº PART NO.	DESCRIPCION DESCRIPTION	4088				OBSERVACIONES REMARKS
1	1DU-E4711-00	SILENCIADOR 1 MUFFLER 1	1				
2	4S9-E4718-01	PROTECTOR DE SILENCIADOR 1 PROTECTOR, MUFFLER 1	1				
3	98980-06012	TORNILLO DE LIGAR SCREW, BIND	3				
4	4S9-E4766-00	ARANDELA DE PROTECTOR WASHER, PROTECTOR	2				
5	90201-06078	ARANDELA PLANA WASHER, PLATE	2				
6	95802-08045	TORNILLO DE REBORDE BOLT, FLANGE	1				
7	90201-088C4	ARANDELA PLANA WASHER, PLATE	1				
8	4S9-E4747-10	AMORTIGUADOR DE SILENCIADOR DAMPER, MUFFLER	1				
9	90387-10817	ESPACIADOR COLLAR	1				
10	90201-08870	ARANDELA PLANA WASHER, PLATE	1				
11	95702-08500	TUERCA DE BRIDA NUT, FLANGE	1				
12	95822-10045	TORNILLO DE REBORDE BOLT, FLANGE	1				
13	92902-10200	ARANDELA WASHER	1				
14	95702-10500	TUERCA DE BRIDA NUT, FLANGE	1				
15	90201-10669	ARANDELA PLANA WASHER, PLATE	1				
16	4S9-E4613-00	JUNTA, TUBO DE ESCAPE GASKET, EXHAUST PIPE	1				
17	95702-06500	TUERCA DE BRIDA NUT, FLANGE	2				

FIG. 9 CARTER

CRANKCASE

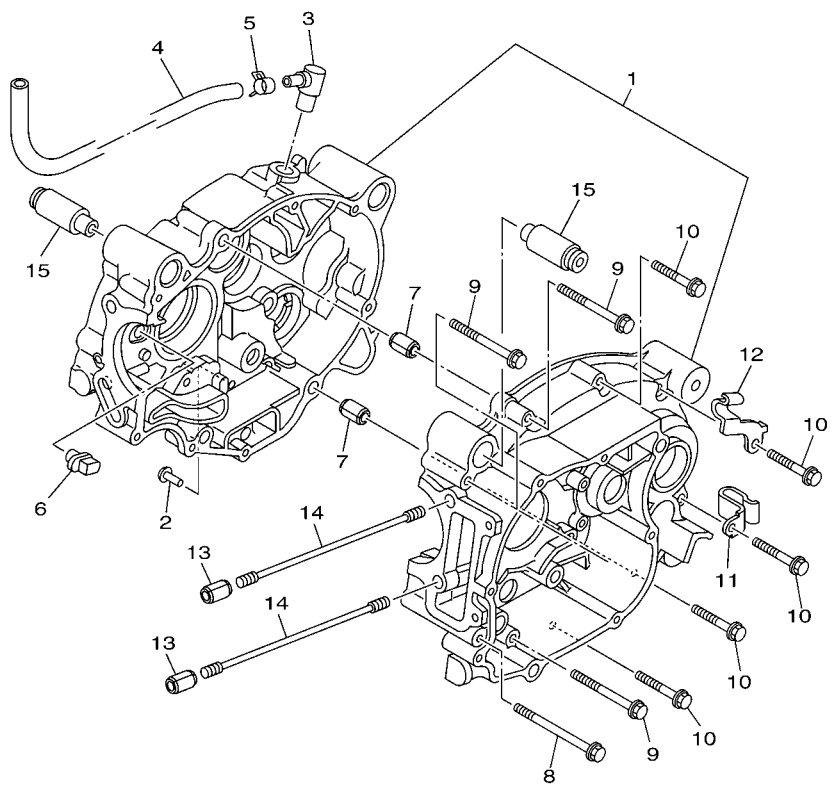

REF. Nº	CODIGO Nº PART NO.	DESCRIPCION DESCRIPTION	4088				OBSERVACIONES REMARKS
1	4S9-E5150-00	CARTER COMPLETO CRANKCASE ASSY	1				
2	4S9-E6346-01	GANCHO DE RESORTE HOOK, SPRING	1				
3	4S9-E5371-00	RESPIRADERO BREATHER	1				
4	4S9-E1166-00	TUBO RESPIRADERO 1 PIPE, BREATHER 1	1				
5	90467-13064	PRESILLA CLIP	1				
6	4S9-E5155-00	BOQUILLA 3 NOZZLE 3	1				
7	99530-10114	PASADOR, DE ESPIGA PIN, DOWEL	2				
8	95022-06080	PERNO, DE BRIDA BOLT, FLANGE	1				
9	95022-06060	PERNO, DE BRIDA BOLT, FLANGE	3				
10	95022-06040	PERNO, DE BRIDA BOLT, FLANGE	5				
11	90465-10833	BRIDA CLAMP	1				
12	90462-10801	BRIDA CLAMP	1				
13	99530-10114	PASADOR, DE ESPIGA PIN, DOWEL	2				
14	90116-08824	ESPARRAGO BOLT, STUD	4				
15	4S9-E5316-00	AMORTIGUADOR 1 DAMPER 1	2				

1DU1600-J090

FIG. 10 CUBIERTA DE CARTER 1

CRANKCASE COVER 1

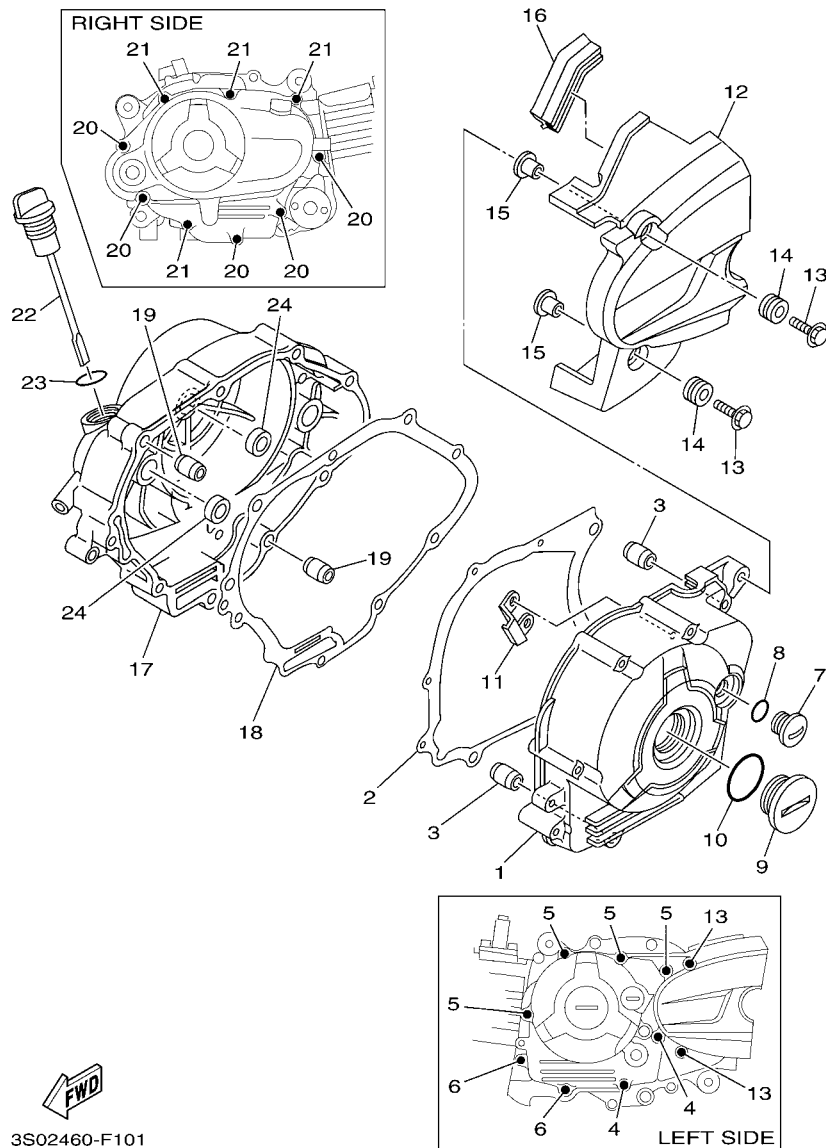

3S02460-F101

REF. N°	CODIGO N° PART NO.	DESCRIPCION DESCRIPTION	4088				OBSERVACIONES REMARKS
1	4S9-E5411-00	CUBIERTA DE CARTER 1 COVER, CRANKCASE 1	1				
2	4S9-E5451-00	EMPAQ DE CUBIERTA DE CARTER GASKET, CRANKCASE COVER 1	1				
3	99530-10114	PASADOR, DE ESPIGA PIN, DOWEL	2				
4	95022-06040	PERNO, DE BRIDA BOLT, FLANGE	2				
5	95022-06050	PERNO, DE BRIDA BOLT, FLANGE	4				
6	95022-06080	PERNO, DE BRIDA BOLT, FLANGE	2				
7	90340-14818	TORNILLO, DE DRENAJE PLUG, STRAIGHT SCREW	1				
8	93210-14899	ANILLO O O-RING	1				
9	90340-32813	TORNILLO, DE DRENAJE PLUG, STRAIGHT SCREW	1				
10	93210-328A4	ANILLO O O-RING	1				
11	4S9-E5113-00	PLACA PLATE	1				
12	4S9-E5418-00	CUBIERTA CAJA DE CADENA COVER, CHAIN CASE	1				
13	95802-06025	TORNILLO DE REBORDE BOLT, FLANGE	2				
14	90480-13568	TAPON GROMMET	2				
15	90387-06063	ESPACIADOR COLLAR	2				
16	4S9-E5492-00	CUBIERTA COVER	1				
17	4S9-E5421-00	TAPA DE CARTER DERECHA COVER, CRANKCASE 2	1				
18	4S9-E5461-00	JUNTA TAPA CARTER DERECHO 2 GASKET, CRANKCASE COVER 2	1				
19	99530-10114	PASADOR, DE ESPIGA PIN, DOWEL	2				
20	95022-06040	PERNO, DE BRIDA BOLT, FLANGE	5				
21	95022-06050	PERNO, DE BRIDA BOLT, FLANGE	4				
22	4S9-E5362-00	TAPON DEL NIVEL DE ACEITE PLUG, OIL LEVEL	1				
23	93210-19809	ANILLO O O-RING	1				
24	93101-10800	SELLO ACEITE OIL SEAL	2				

FIG. 11 ARRANQUE

STARTER

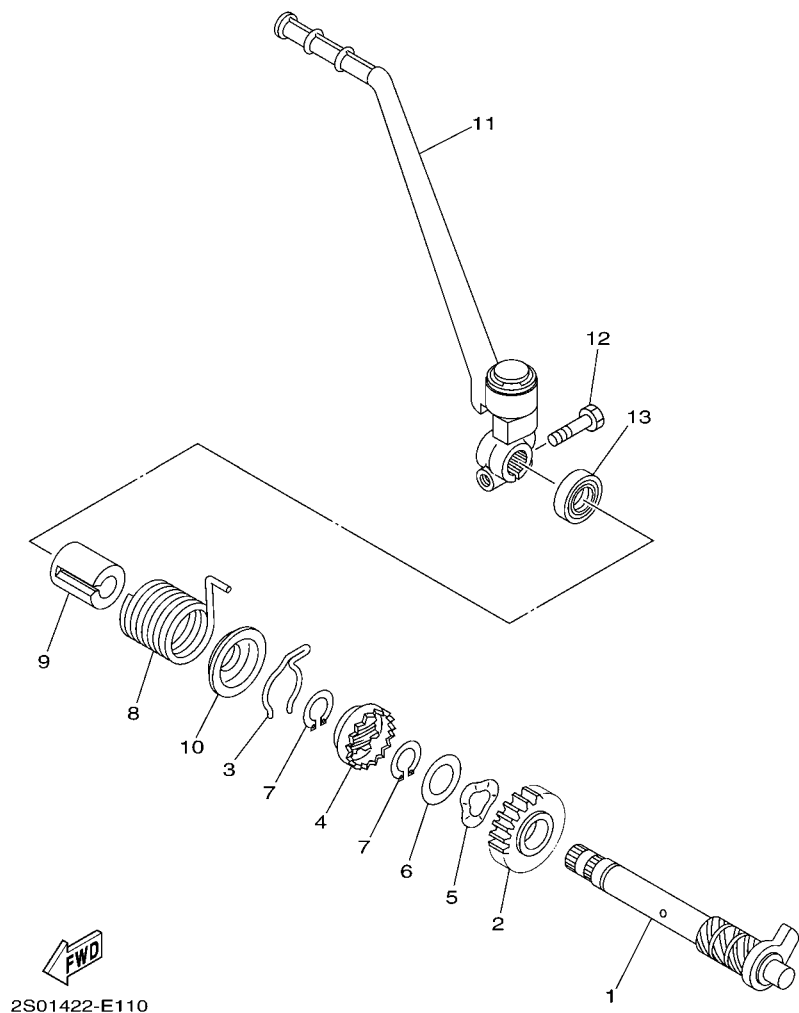

REF. N°	CODIGO N° PART NO.	DESCRIPCION DESCRIPTION	4088				OBSERVACIONES REMARKS
1	4S9-E5660-00	EJE DEL PEDAL DE ARRAN.COMPLET KICK AXLE ASSY	1				
2	4S9-E5641-00	ENGRANAJE PEDAL ARRANQUE GEAR, KICK	1				
3	90468-26800	PRESILLA CLIP	1				
4	4S9-E5671-00	RUEDA DE TRINQUETE WHEEL, RATCHET	1				
5	90206-19027	ARANDELA ONDULADA WASHER, WAVE	1				
6	4S9-E5644-00	CUNA SHIM	1				
7	99009-19400	PRESILLA REDONDA CIRCLIP	2				
8	90508-26810	RESORTE DE TORSION SPRING, TORSION	1				
9	4S9-E5664-00	GUIA DE RESORTE GUIDE, SPRING	1				
10	4S9-E5664-10	GUIA DE RESORTE GUIDE, SPRING	1				
11	4S9-E5620-00	PEDAL DE ARRANQUE COMPLETO KICK CRANK ASSY	1				
12	97012-06025	PERNO BOLT	1				
13	93102-15807	SELLO ACEITE OIL SEAL	1				

FIG. 12 EMBRAGUE DEL ARRANQUE STARTER CLUTCH

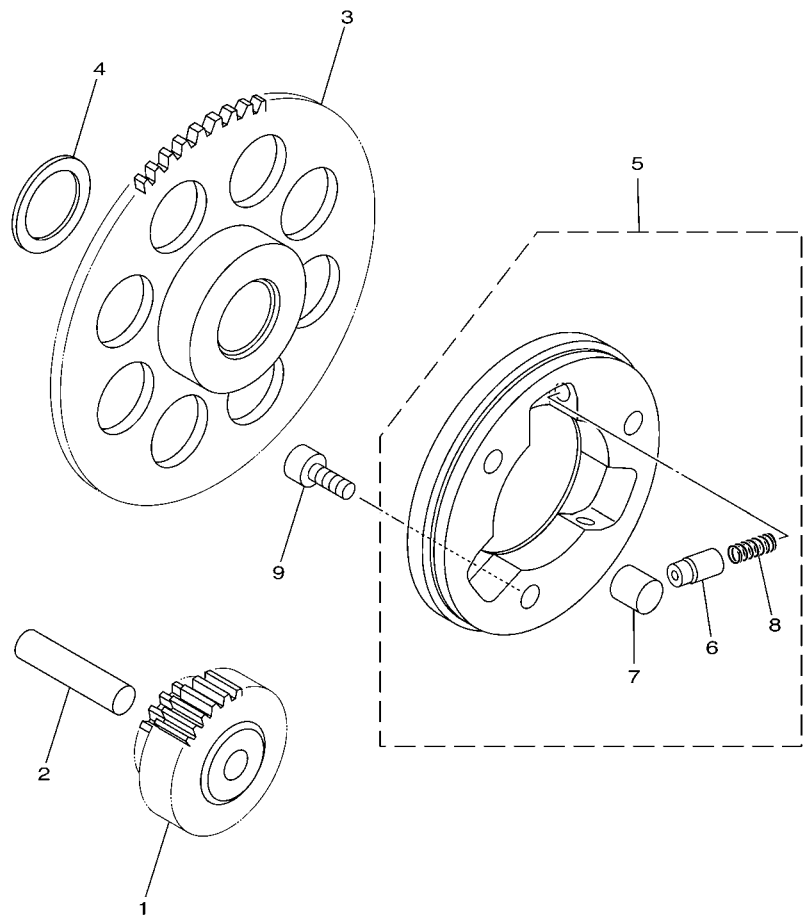

5TN1431-B120

REF. Nº	CODIGO Nº PART NO.	DESCRIPCION DESCRIPTION	4088				OBSERVACIONES REMARKS
1	4S9-E5512-00	ENGRENAJE NEUTRO GEAR, IDLER 1	1				
2	93608-43800	PASADOR DE CLAVIJA PIN, DOWEL	1				
3	4S9-E5524-00	RUEDA DE ARRANQUE WHEEL, STARTER	1				
4	4S9-E5644-00	CUNA SHIM	1				
5	4S9-E5580-00	ENSAMBLE EXT. EMBRAGUE ARRANQUE STARTER CLUTCH OUTER ASSY	1				
6	4S9-E5583-00	TAPA RESORTE EMBRAG. ARRANQ. CAP, STARTER CLUTCH SPRING	3				
7	93610-10174	PASADOR DE CLAVIJA PIN, DOWEL	3				
8	90501-02639	RESORTE DE COMPRESION SPRING, COMPRESSION	3				
9	91312-06012	TORNILLO BOLT	3				

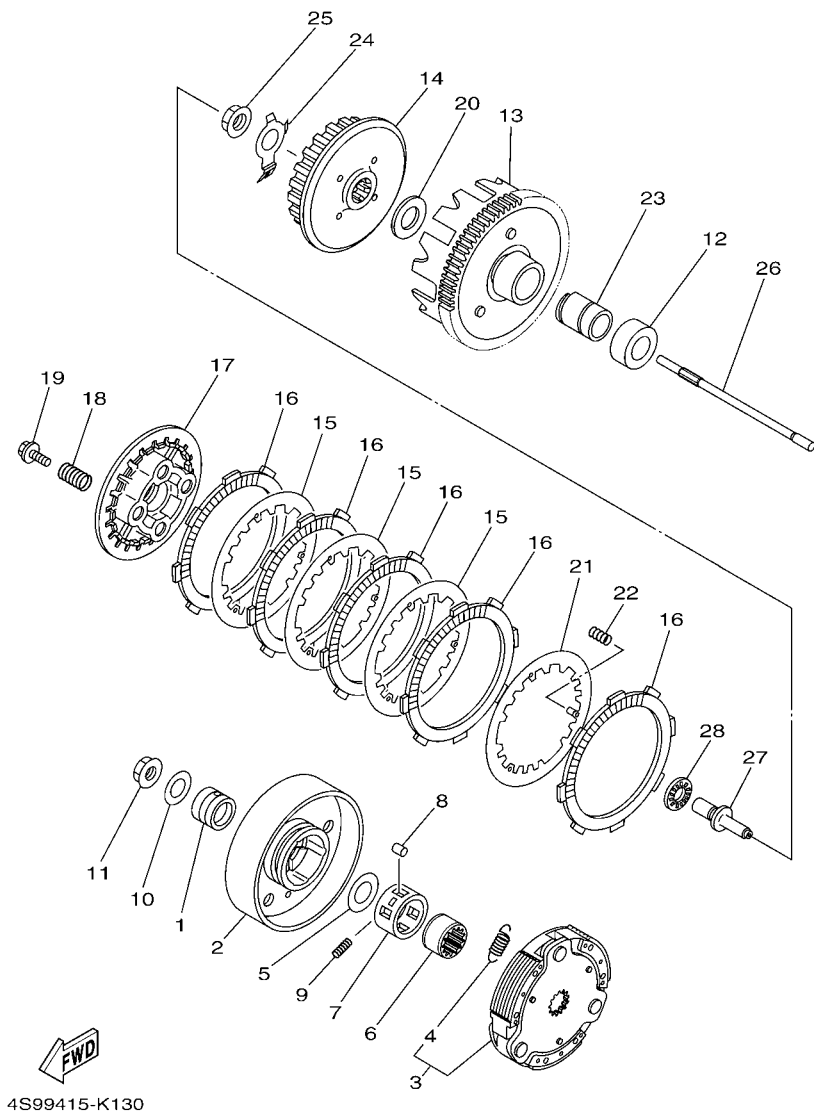
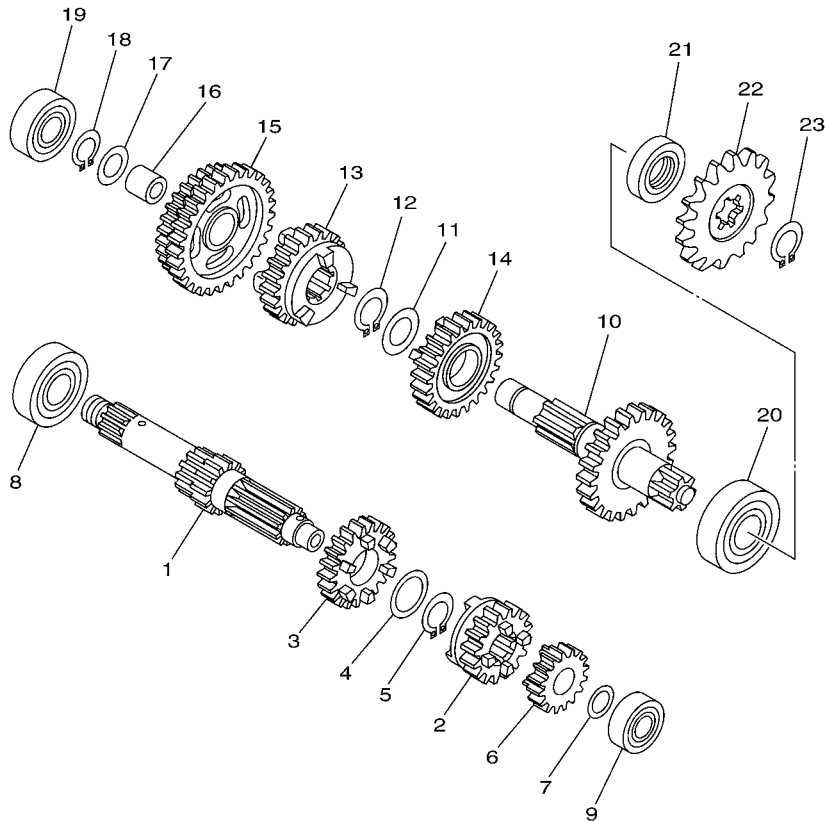

FIG. 13 EMBRAGUE

CLUTCH

REF. Nº	CODIGO Nº PART NO.	DESCRIPCION DESCRIPTION	4088				OBSERVACIONES REMARKS
1	90387-16812	ESPACIADOR COLLAR	1				
2	4S9-E6611-10	CAJA DE EMBRAGUE COMPLETO CLUTCH HOUSING COMP.	1				
3	4S9-E6620-10	PORTADOR DE EMBRAGUE COMPLETO CLUTCH CARRIER ASSY	1				
4	4S9-E6626-10	.RESORTE CONTRAPESO EMBRAGUE 1 .SPRING, CLUTCH WEIGHT 1	3				
5	90201-167P7	ARANDELA PLANA WASHER, PLATE	1				
6	4S9-E6512-00	COPA DE CAJA DE EMBRAGUE BOSS, CLUTCH HOUSING	1				
7	4S9-E6586-00	MEDITOR CAGE	1				
8	93606-10801	PASADOR DE CLAVIJA PIN, DOWEL	3				
9	90501-04802	RESORTE DE COMPRESION SPRING, COMPRESSION	1				
10	90201-12820	ARANDELA PLANA WASHER, PLATE	1				
11	90179-12803	TUERCA NUT	1				
12	90560-17384	SEPARADOR SPACER	1				
13	4S9-E6150-10	CAMPANA DE EMBRAGUE PRIMARY DRIVEN GEAR COMP.	1				
14	4S9-E6371-10	CUBO, DE EMBRAGUE BOSS, CLUTCH	1				
15	4S9-E6324-10	PLACA DE EMBRAGUE PLATE, CLUTCH 1	3				
16	4S9-E6321-10	PLACA DE FRICCION PLATE, FRICTION	5				
17	4S9-E6351-10	PLATO DE PRESION PLATE, PRESSURE 1	1				
18	90501-20804	RESORTE DE COMPRESION SPRING, COMPRESSION	4				
19	90159-05805	TORNILLO CON VALONA SCREW, WITH WASHER	4				
20	4S9-E6154-10	ARANDELA, DE EMPUJE 1 PLATE, THRUST 1	1				
21	4S9-E6350-10	PLACA DE PRESION COMPLETA PRESSURE PLATE ASSY	1				
22	90501-05802	RESORTE DE COMPRESION SPRING, COMPRESSION	3				
23	90387-17805	ESPACIADOR COLLAR	1				
24	4S9-E6135-00	ARANDELA DE CIERRE WASHER, LOCK	1				
25	90179-14803	TUERCA NUT	1				
26	4S9-E6357-00	VARILLA DE EMPUJE 2 ROD, PUSH 2	1				
27	4S9-E6356-00	VARILLA DE EMPUJE 1 ROD, PUSH 1	1				



40B6516-M140

FIG. 14 TRANSMISION

TRANSMISION

REF. N°	CODIGO N° PART NO.	DESCRIPCION DESCRIPTION	40B8				OBSERVACIONES REMARKS
1	4S9-E7411-10	EJE PRIMARIO (12T) AXLE, MAIN (12T)	1				
2	4S9-E7131-10	ENGRANAJE PINON DE 3RA (21T) GEAR, 3RD PINION (21T)	1				
3	4S9-E7141-10	ENGRANAJE PINON DE 4TA (21T) GEAR, 4TH PINION (21T)	1				
4	90201-20266	ARANDELA, PLACA (T=1.0) WASHER, PLATE (T=1.0)	1				
5	93410-20809	SEGURO CIRCLIP	1				
6	4S9-E7121-10	ENGRANAJE DE PINON DE 2DA(17T) GEAR, 2ND PINION (17T)	1				
7	90201-128C9	ARANDELA PLANA WASHER, PLATE	1				
8	93306-203XE	COJINETE BEARING	1				
9	93306-001X8	COJINETE BEARING	1				
10	4S9-E7402-10	EJE DE TRACCION COMPLETO (33T) DRIVE AXLE ASSY (33T)	1				
11	90201-20266	ARANDELA, PLACA (T=1.0) WASHER, PLATE (T=1.0)	1				
12	93410-20809	SEGURO CIRCLIP	1				
13	4S9-E7241-10	ENGRANAJE DE RUEDA 4TA (23T) GEAR, 4TH WHEEL (23T)	1				
14	4S9-E7231-10	ENGRANAJE RUEDA DE 3RA (29T) GEAR, 3RD WHEEL (29T)	1				
15	4S9-E7211-10	ENGRANAJE RUEDA DE 1 RA 30/38T GEAR, 1ST WHEEL (30T/38T)	1				
16	90387-1503D	ESPACIADOR COLLAR	1				
17	90201-15700	ARANDELA PLANA WASHER, PLATE	1				
18	99009-15400	PRESILLA REDONDA CIRCLIP	1				
19	93306-252XJ	COJINETE BEARING	1				
20	93306-204XF	COJINETE BEARING	1				
21	93102-20802	SELLO ACEITE OIL SEAL	1				
22	93822-15817	CORONA (15T) SPROCKET, DRIVE (15T)	1				
23	93410-20809	SEGURO CIRCLIP	1				

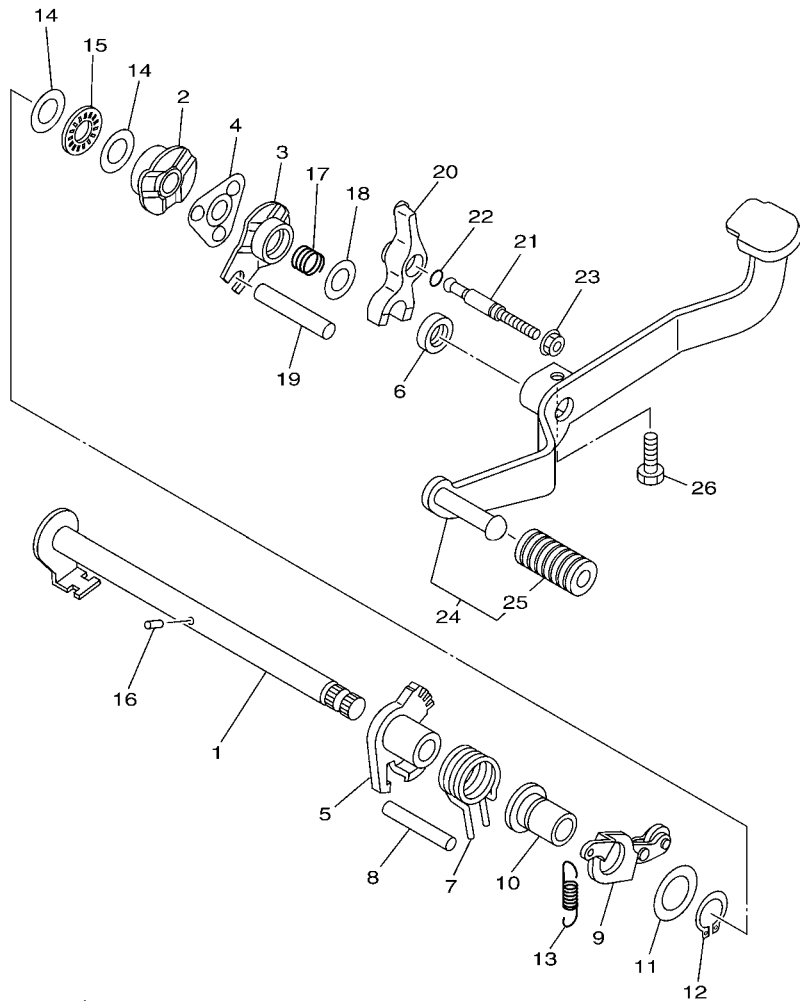

4S91415-F150

FIG. 16 EJE DE CAMBIO & PEDAL SHIFT SHAFT

REF. N°	CODIGO N° PART NO.	DESCRIPCION DESCRIPTION	4088				OBSERVACIONES REMARKS
1	4S9-E8101-00	EJE SELECTOR COMPLETO SHIFT SHAFT ASSY	1				
2	4S9-E8179-00	GUIA GUIDE	1				
3	4S9-E8172-00	GUIA DE CAMBIO GUIDE, SHIFT	1				
4	4S9-E8181-00	SOSTEN DE SUJETADOR HOLDER, PAWL	1				
5	4S9-E8152-00	PALANCA DE CAMBIO 4 LEVER, SHIFT 4	1				
6	93102-12806	SELLO ACEÍTE OIL SEAL	1				
7	90508-29007	RESORTE DE TORSION SPRING, TORSION	1				
8	93608-50149	PASADOR DE CLAVIJA PIN, DOWEL	1				
9	4S9-E8140-00	PALANCA DE TOPE COMPLETA STOPPER LEVER ASSY	1				
10	4S9-E8699-00	COPA 1 BOSS 1	1				
11	90201-178D3	ARANDELA PLANA WASHER, PLATE	1				
12	99009-17400	PRESILLA REDONDA CIRCLIP	1				
13	4S9-E8337-00	RESORTE SPRING	1				
14	90201-127F4	ARANDELA PLANA WASHER, PLATE	2				
15	93340-212Y6	COJINETES CON RODAMIENTOS BEARING	1				
16	93604-10837	PASADOR DE CLAVIJA PIN, DOWEL	1				
17	90501-12805	RESORTE DE COMPRESION SPRING, COMPRESSION	1				
18	90201-12045	ARANDELA PLANA WASHER, PLATE	1				
19	4S9-E8173-00	PASADOR CAMBIO PIN, SHIFT	1				
20	4S9-E817A-00	BRAZO, DE CAMBIO 3 ARM, SHIFT 3	1				
21	4S9-E8186-00	TORNILLO DE AJUSTE SCREW, ADJUSTING	1				
22	93210-06806	ANILLO O O-RING	1				
23	95702-06500	TUERCA DE BRIDA NUT, FLANGE	1				
24	4S9-E8110-00	PEDAL DE CAMBIO COMPLETO SHIFT PEDAL ASSY	1				
25	4S9-E8113-00	FUNDA DEL PEDAL DEL CAMBIO COVER, SHIFT PEDAL	1				
26	97022-08020	PERNO BOLT, HEXAGON	1				

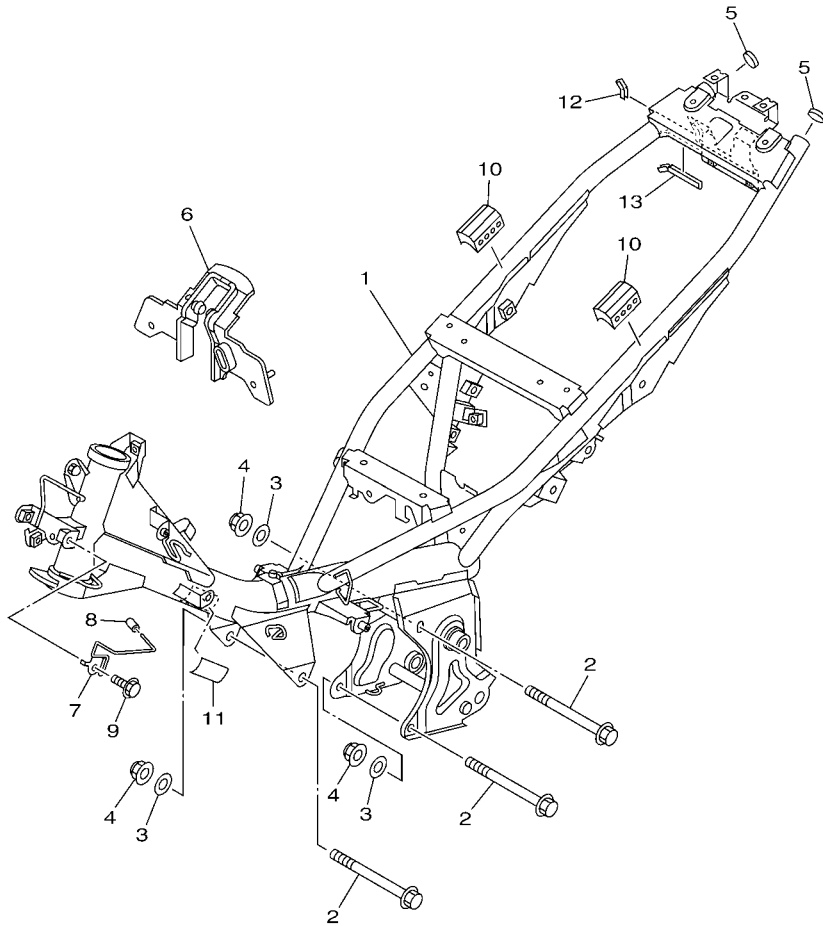

FWD
40B3276-K170

FIG. 17 CUADRO

FRAME

REF. Nº	CODIGO Nº PART NO.	DESCRIPCION DESCRIPTION	40B8				OBSERVACIONES REMARKS
1	40B-F1110-02	ARMAZON COMPLETO FRAME COMP.	1				
2	95812-08120	TORNILLO DE REBORDE BOLT, FLANGE	3				
3	90201-08043	ARANDELA PLANA WASHER, PLATE	3				
4	95602-08200	TUERCA DE AUTO-CIERRE NUT, SELF-LOCKING	3				
5	4S9-F139R-00	CUBIERTA 2 COVER 2	2				
6	4S9-F117R-00	CUBIERTA 4 COVER 4	1				
7	4S9-F1679-20	SOPORTE DE CONJUNT HOLDER, HARNESS	1				
8	4S9-F113B-00	AMORTIGUADOR DAMPER	1				
9	95802-06010	TORNILLO DE REBORDE BOLT, FLANGE	1				
10	4S9-F139U-00	AMORTIGUADOR 2 DAMPER 2	2				
11	4S9-F111D-01	SELLO 1 SEAL 1	1				
12	90520-02801	EQUILIBRIO, CUBIERTA DAMPER, PLATE	1				
13	90520-02802	EQUILIBRIO, CUBIERTA DAMPER, PLATE	1				

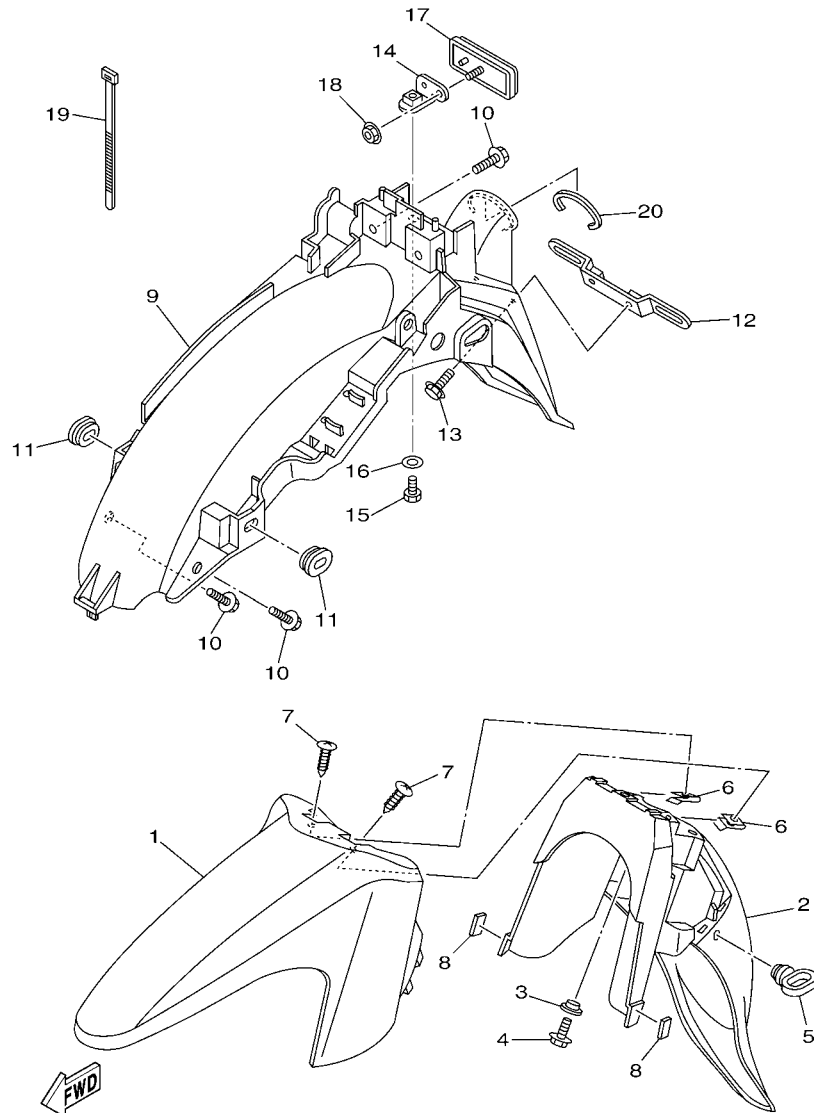

40B1516-G180

FIG. 18 GUARDABARRO

FENDER

REF. Nº	CODIGO Nº PART NO.	DESCRIPCION DESCRIPTION	40B8				OBSERVACIONES REMARKS
1	40B-F1511-00-P0	GUARDABARRO DELANTERO FENDER, FRONT	1				UR PARA DRMK UR FOR DRMK
	40B-F1511-00-P1	GUARDABARRO DELANTERO FENDER, FRONT	1				UR PARA SMX UR FOR SMX
	40B-F1511-00-P3	GUARDABARRO DELANTERO FENDER, FRONT	1				UR PARA DPBMC UR FOR DPBMC
2	4S9-F1556-01	GUARDABARRO, DELANTERO 2 FENDER, FRONT 2	1				
3	90387-06857	ESPACIADOR COLLAR	3				
4	97522-06520	TORNILLO HEXAGONAL CON RONDONA BOLT, WITH WASHER	3				
5	4S9-F1518-01	SOPORTE DE CABLE HOLDER, CABLE	1				
6	90183-05807	TUERCA DE RESORTE NUT, SPRING	2				
7	97702-50014	TORNILLO ROSCA HEMBRA SCREW, TAPPING	2				
8	4S9-F8371-00	AMORTIGUADOR DAMPER	2				
9	40B-F1611-01	GUARDABARRO TRASERO FENDER, REAR	1				
10	90119-06869	TORNILLO CON ARANDELA BOLT, WITH WASHER	4				
11	90480-01559	TAPON GROMMET	2				
12	40B-F1685-00	SOPORTE DE LICENCIA BRACKET, LICENSE	1				
13	90119-068A8	TORNILLO CON ARANDELA BOLT, WITH WASHER	2				
14	40B-F113J-00	SOPORTE, REFLECTOR 1 BRACKET, REFLECTOR 1	1				
15	97002-05012	PERNO BOLT	1				
16	92902-05200	ARANDELA WASHER	1				
17	4P7-H5130-01	REFLECTOR TRASERO COMPLETO REAR REFLECTOR ASSY	1				
18	95702-05500	TUERCA DE BRIDA NUT, FLANGE	1				
19	4S9-H3936-00	BANDA DE CABLE DE INTERRUPTOR BAND, SWITCH CORD	1				
20	90520-05804	EQUILIBRIO, CUBIERTA DAMPER, PLATE	1				

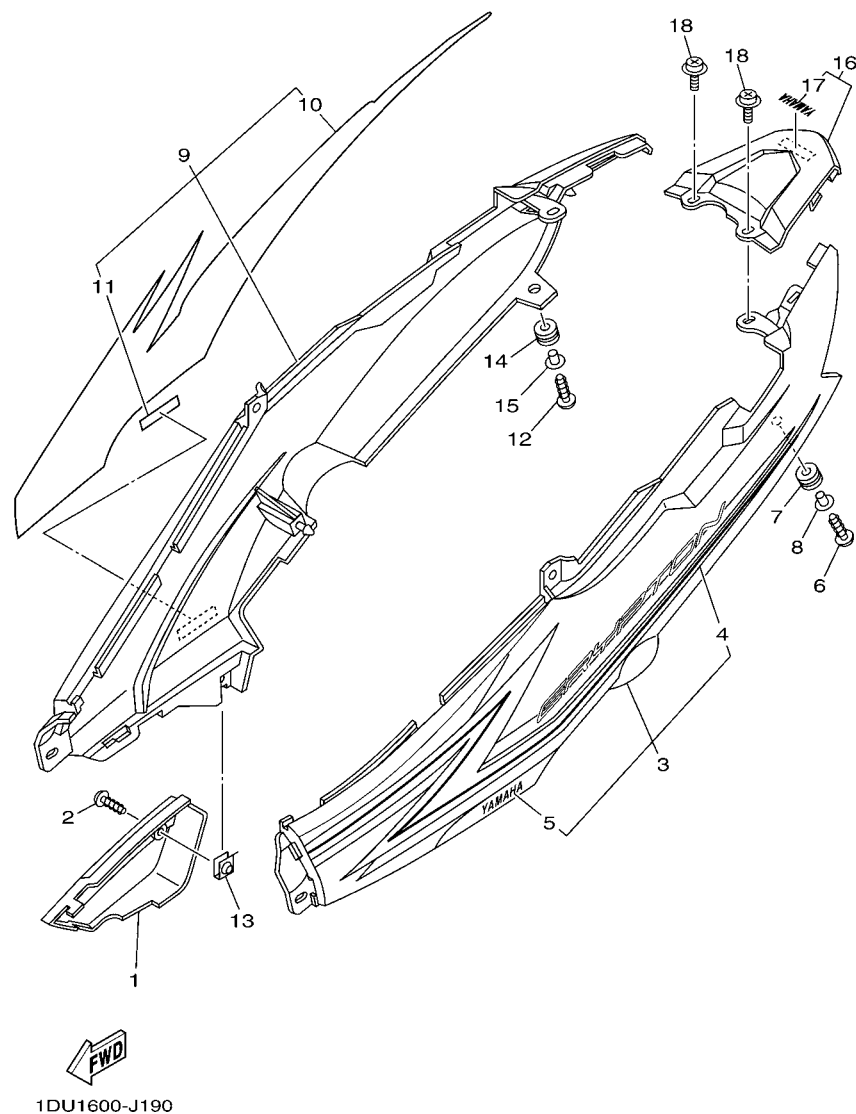

1DU1600-J190

FIG. 19 CUBIERTA LATERAL

SIDE COVER

REF. Nº	CODIGO Nº PART NO.	DESCRIPCION DESCRIPTION	4088				OBSERVACIONES REMARKS
1	4S9-F1721-00	CUBIERTA LATERAL 2 COVER, SIDE 2	1				
2	97702-50014	TORNILLO ROSCA HEMBRA SCREW, TAPPING	1				
3	4S9-XF173-10-P0	TAPA LATERAL 3 COVER, SIDE 3	1				UR PARA DRMK UR FOR DRMK
	4S9-XF173-10-P1	TAPA LATERAL 3 COVER, SIDE 3	1				UR PARA SMX UR FOR SMX
	4S9-XF173-10-P3	TAPA LATERAL 3 COVER, SIDE 3	1				UR SMX PARA DPBMC UR SMX FOR DPBMC
4	4S9-F173E-30	.GRAFICO, 1 .GRAPHIC 1	1				UR PARA DRMK UR FOR DRMK
	4S9-F173E-40	.GRAFICO, 1 .GRAPHIC 1	1				UR PARA SMX UR FOR SMX
	4S9-F173E-50	.GRAFICO, 1 .GRAPHIC 1	1				UR PARA DPBMC UR FOR DPBMC
5	99246-00100	.EMBLEMA, YAMAHA .EMBLEM, YAMAHA	1				
6	97702-50025	TORNILLO ROSCA HEMBRA SCREW, TAPPING	1				
7	90480-12808	TAPON GROMMET	1				
8	90387-06855	ESPACIADOR COLLAR	1				
9	4S9-XF174-10-P0	CUBIERTA LATERAL 4 COVER, SIDE 4	1				UR PARA DRMK UR FOR DRMK
	4S9-XF174-10-P1	CUBIERTA LATERAL 4 COVER, SIDE 4	1				UR PARA SMX UR FOR SMX
	4S9-XF174-10-P3	CUBIERTA LATERAL 4 COVER, SIDE 4	1				UR SMX PARA DPBMC UR SMX FOR DPBMC
10	4S9-F173F-30	.GRAFICO 2 .GRAPHIC 2	1				UR PARA DRMK UR FOR DRMK
	4S9-F173F-40	.GRAFICO 2 .GRAPHIC 2	1				UR PARA SMX UR FOR SMX
	4S9-F173F-50	.GRAFICO 2 .GRAPHIC 2	1				UR PARA DPBMC UR FOR DPBMC
11	99246-00100	.EMBLEMA, YAMAHA .EMBLEM, YAMAHA	1				
12	97702-50025	TORNILLO ROSCA HEMBRA SCREW, TAPPING	1				
13	90183-05807	TUERCA DE RESORTE NUT, SPRING	1				
14	90480-12808	TAPON GROMMET	1				
15	90387-06855	ESPACIADOR COLLAR	1				
16	4S9-XF171-10-P0	CUBIERTA LATERAL 5 COVER, SIDE 5	1				DRMK(DRMK) DRMK(DRMK)
	4S9-XF171-00-P0	CUBIERTA LATERAL 5 COVER, SIDE 5	1				SMX(SMX,DPBMC) SMX(SMX,DPBMC)
17	4S9-F153E-00	.EMBLEMA, YAMAHA .EMBLEM, YAMAHA	1				
18	90159-06842	TORNILLO CON VALONA SCREW, WITH WASHER	2				

FIG. 20 BRAZO TRASERO & SUSPENSION REAR ARM & SUSPENSION

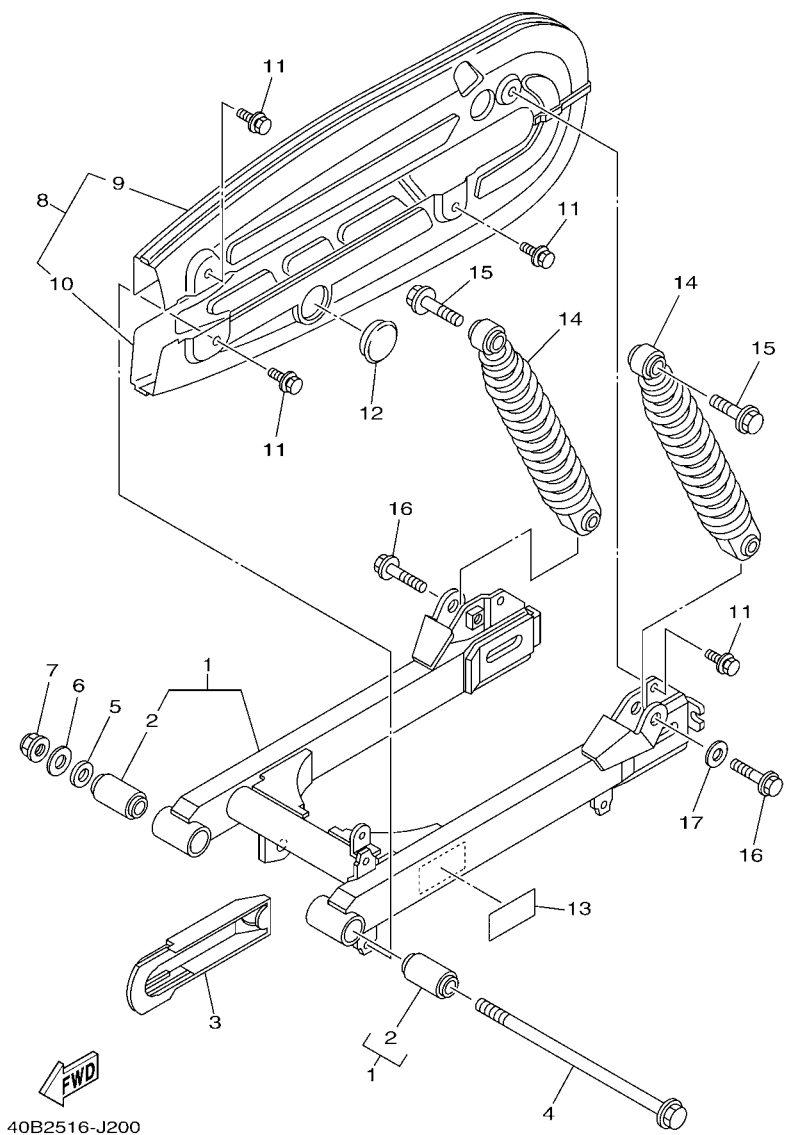

40B2516-J200

REF. Nº	CODIGO Nº PART NO.	DESCRIPCION DESCRIPTION	40B8				OBSERVACIONES REMARKS
1	4S9-F2100-01-WN	BRAZO TRASERO COMPLETO REAR ARM ASSY	1				CIS CIS
2	4S9-F2123-00	.BUJE 1 .BUSH 1	2				
3	4S9-F2151-01	SELLO DE GUARDA SEAL, GUARD	1				
4	4S9-F2141-00	EJE DEL BARCULANTE SHAFT, PIVOT	1				
5	90201-128D0	ARANDELA PLANA WASHER, PLATE	1				
6	90201-128F3	ARANDELA PLANA WASHER, PLATE	1				
7	95602-12200	TUERCA DE AUTO-CIERRE NUT, SELF-LOCKING	1				
8	4S9-F2310-00	CAJA DE CADENA COMPLETA CHAIN CASE ASSY	1				
9	4S9-F2311-00	.CABRECADENA .CASE, CHAIN	1				
10	4S9-F2312-00	.CAJA DE CADENA 2 .CASE, CHAIN 2	1				
11	97502-06510	PERNO CON ARANDELA BOLT, WITH WASHER	4				
12	4S9-F2315-00	TAPA CAP	1				
13	40B-F1668-20	ETIQUETA DE FRANJA LABEL, TIRE	1				
14	4S9-F2210-11	AMORTIGUADOR TRASERO COMPLETO SHOCK ABSORBER ASSY, REAR	2				
15	90105-12802	TORNILLO BOLT, FLANGE	2				
16	90105-10870	TORNILLO BOLT, FLANGE	2				
17	90201-10831	ARANDELA PLANA WASHER, PLATE	1				

FIG. 21 DIRECCION

STEERING

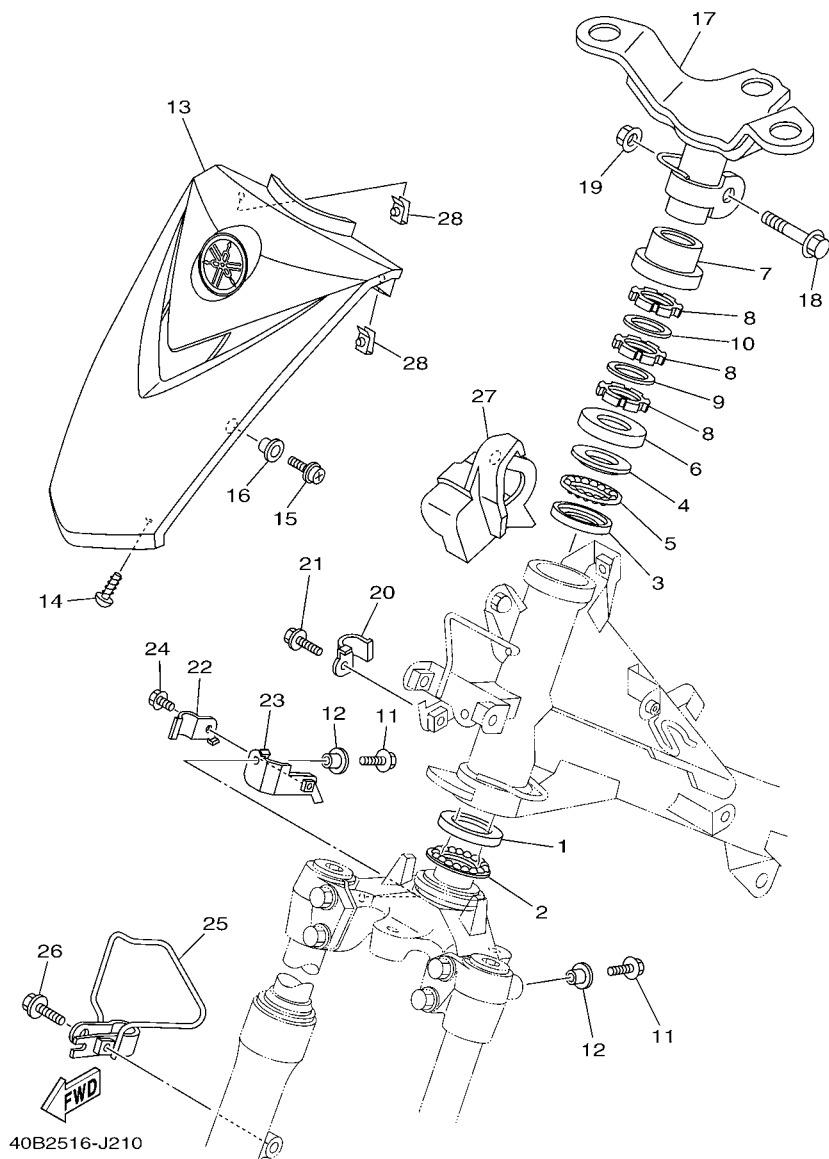

REF. N°	CODIGO Nº PART NO.	DESCRIPCION DESCRIPTION	40B8				OBSERVACIONES REMARKS
1	4KL-F3412-00	PISTA DE BOLAS 2 RACE, BALL 2	1				
2	5WG-F341E-00	RETEN DE COJINETE RETAINER, BALL BEARING	1				
3	5WB-F3412-00	PISTA DE BOLAS 2 RACE, BALL 2	1				
4	5WB-F3411-00	PISTA DE BOLAS 1 RACE, BALL 1	1				
5	5WG-F341E-10	RETEN DE COJINETE RETAINER, BALL BEARING	1				
6	4S9-F3416-01	CUBIERTA DE BASE DE BOLA 2 COVER, BALL RACE 2	1				
7	4S9-F3415-00	CUBIERTA DE PISTA DE BOLAS 1 COVER, BALL RACE 1	1				
8	90179-25809	TUERCA NUT	3				
9	90202-26803	ARANDELA DE PLANA WASHER, PLATE	1				
10	4S9-F3418-01	ARANDELA ESPECIAL WASHER, SPECIAL	1				
11	95022-06016	PERNO, DE BRIDA BOLT, FLANGE	2				
12	90387-06857	ESPACIADOR COLLAR	2				
13	40B-XF339-40-P0	PANEL DELANTERO PANEL, FRONT	1				SMX(DRMK,DPBMC)
	40B-XF339-50-P1	PANEL DELANTERO PANEL, FRONT	1				BS4(SMX) BS4(SMX)
14	97702-50012	TORNILLO ROSCA HEMBRA SCREW, TAPPING	2				
15	90159-06842	TORNILLO CON VALONA SCREW, WITH WASHER	2				
16	90387-062M9	ESPACIADOR COLLAR	2				
17	4S9-F3461-00	SOPORTE DE MANUBRIO BRACKET, HANDLE	1				
18	90105-10036	TORNILLO BOLT, FLANGE	1				
19	95602-10200	TUERCA DE AUTO-CIERRE NUT, U FLANGE	1				
20	4S9-F5887-01	SOPORTE DE MANGUERA FRENO HOLDER, BRAKE HOSE	1				
21	95022-06010	PERNO, DE BRIDA BOLT, FLANGE	1				
22	4S9-F5886-01	SOPORTE DE MANGUERA FRENO HOLDER, BRAKE HOSE	1				
23	4S9-F5875-01	SOPORTE DE MANGUERA FRENO 1 HOLDER, BRAKE HOSE 1	1				
24	95022-06010	PERNO, DE BRIDA BOLT, FLANGE	1				
25	4S9-F331E-01	GUIA DE CABLE GUIDE, CABLE	1				
26	95022-06025	PERNO, DE BRIDA BOLT, FLANGE	1				

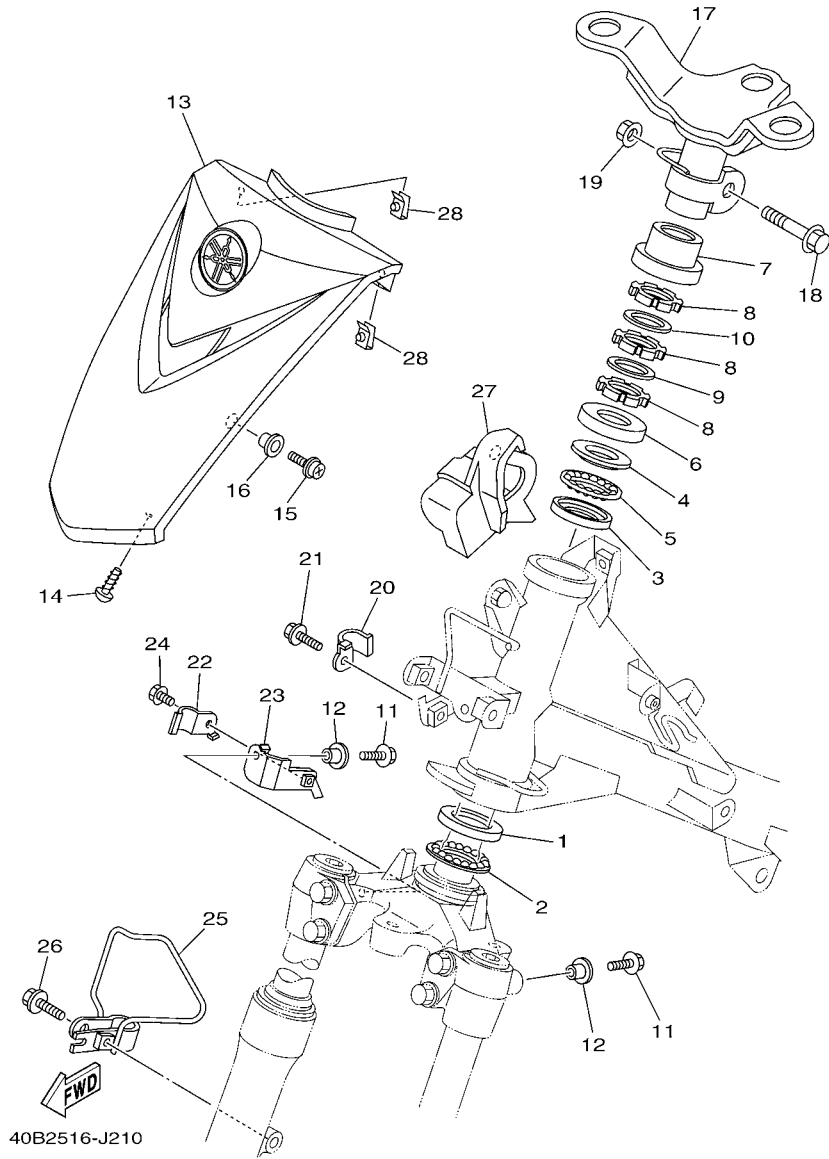
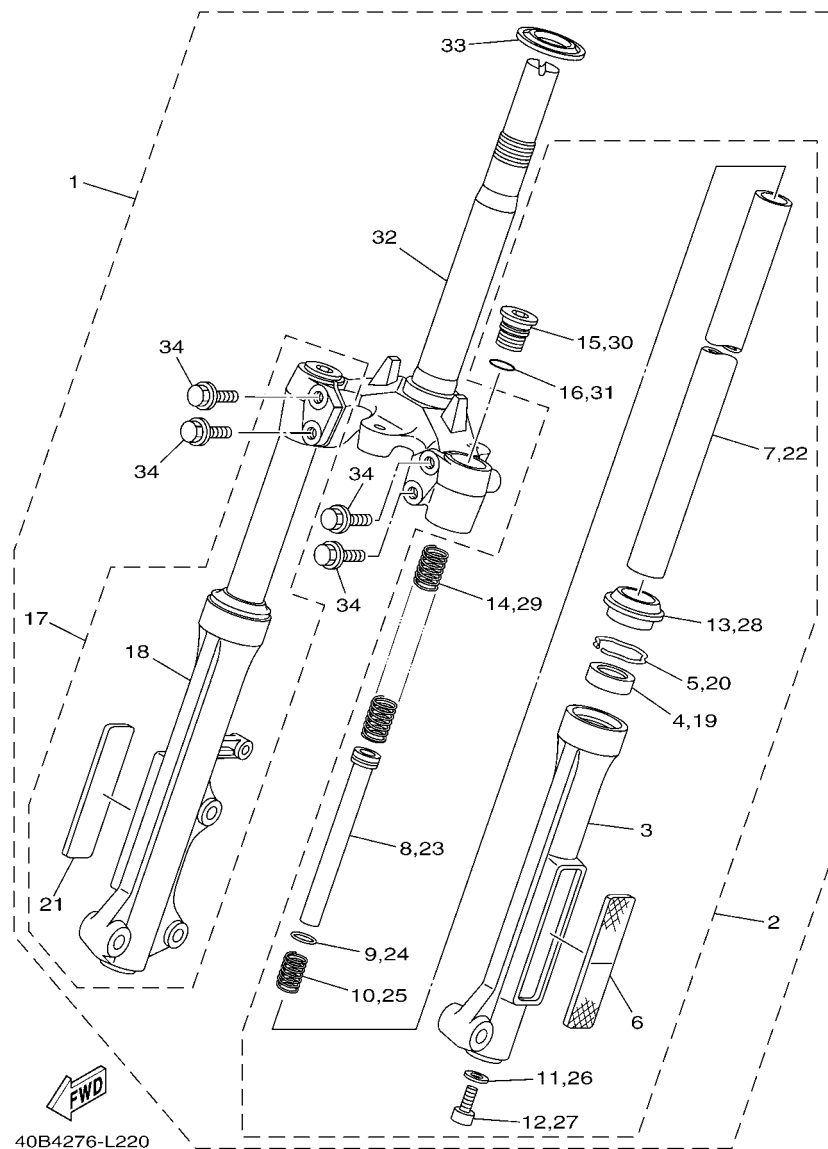

FIG. 21 DIRECCION

STEERING

REF. Nº	CODIGO Nº PART NO.	DESCRIPCION DESCRIPTION	40B8				OBSERVACIONES REMARKS
27	4S9-F3472-00	PROTECTOR PROTECTOR	1				
28	90183-05807	TUERCA DE RESORTE NUT, SPRING	2				



40B4276-L220

FIG. 22 HORQUILLA DELANTERA FRONT FORK

REF. Nº	CODIGO Nº PART NO.	DESCRIPCION DESCRIPTION	4088				OBSERVACIONES REMARKS
1	40B-F3100-30	HORQUILLA DELANTERA COMPLETA FRONT FORK ASSY	1				
2	40B-F3102-30	..HORQUILLA DELANTERA COMPL.(MI) ..FRONT FORK ASSY (L.H)	1				
3	4S9-F3126-10	..TUBO EXTERIOR (IZQUIERDO) ..TUBE, OUTER (LEFT)	1				
4	5WB-F3145-00	..RETEN DE ACEITE ..OIL SEAL	1				
5	5WB-F3156-00	..ANILLO DE ENGANCHE ..RING, SNAP	1				
6	4S9-H5110-10	..REFLECTOR COMPLETO ..REFLECTOR ASSY	1				
7	4S9-F3110-10	..TUBO INTERIOR COMPLETO 1 ..INNER TUBE COMP.1	1				
8	4S9-F3170-10	..CILINDRO COMPL DE HORQ DELANT ..CYLINDER COMP., FRONT FORK	1				
9	4S9-F3157-10	..ANILLO DEL PISTON ..RING, PISTON	1				
10	5WB-F3152-00	..RESORTE DE SUBENSAMBLE ..SPRING, SUB	1				
11	5WB-F3158-00	..EMPAQUE ..GASKET	1				
12	5WB-F3181-00	..TORNILLO CABEZAHEXAGONAL ..BOLT, HEXAGON SOCKET HEAD	1				
13	4RT-F3144-20	..GUARDAPOLVO ..SEAL, DUST	1				
14	4S9-F3141-10	..RESORTE HORQUILLA DELANT. ..SPRING, FRONT FORK	1				
15	4S9-F3111-10	..PERNO DE TAPA ..BOLT, CAP	1				
16	5WB-F3147-00	..ARO ..O-RING	1				
17	40B-F3103-30	..HORQUILLA DELANTERA COMPL.(MD) ..FRONT FORK ASSY (R.H)	1				
18	4S9-F3136-10	..TUBO EXTERIOR (DERECHO) ..TUBE, OUTER (RIGHT)	1				
19	5WB-F3145-00	..RETEN DE ACEITE ..OIL SEAL	1				
20	5WB-F3156-00	..ANILLO DE ENGANCHE ..RING, SNAP	1				
21	4S9-H5110-10	..REFLECTOR COMPLETO ..REFLECTOR ASSY	1				
22	4S9-F3110-10	..TUBO INTERIOR COMPLETO 1 ..INNER TUBE COMP.1	1				
23	4S9-F3170-10	..CILINDRO COMPL DE HORQ DELANT ..CYLINDER COMP., FRONT FORK	1				
24	4S9-F3157-10	..ANILLO DEL PISTON ..RING, PISTON	1				
25	5WB-F3152-00	..RESORTE DE SUBENSAMBLE ..SPRING, SUB	1				
26	5WB-F3158-00	..EMPAQUE ..GASKET	1				
27	5WB-F3181-00	..TORNILLO CABEZAHEXAGONAL ..BOLT, HEXAGON SOCKET HEAD	1				

FIG. 23 DEPOSITO DE COMBUSTIBLE FUEL TANK

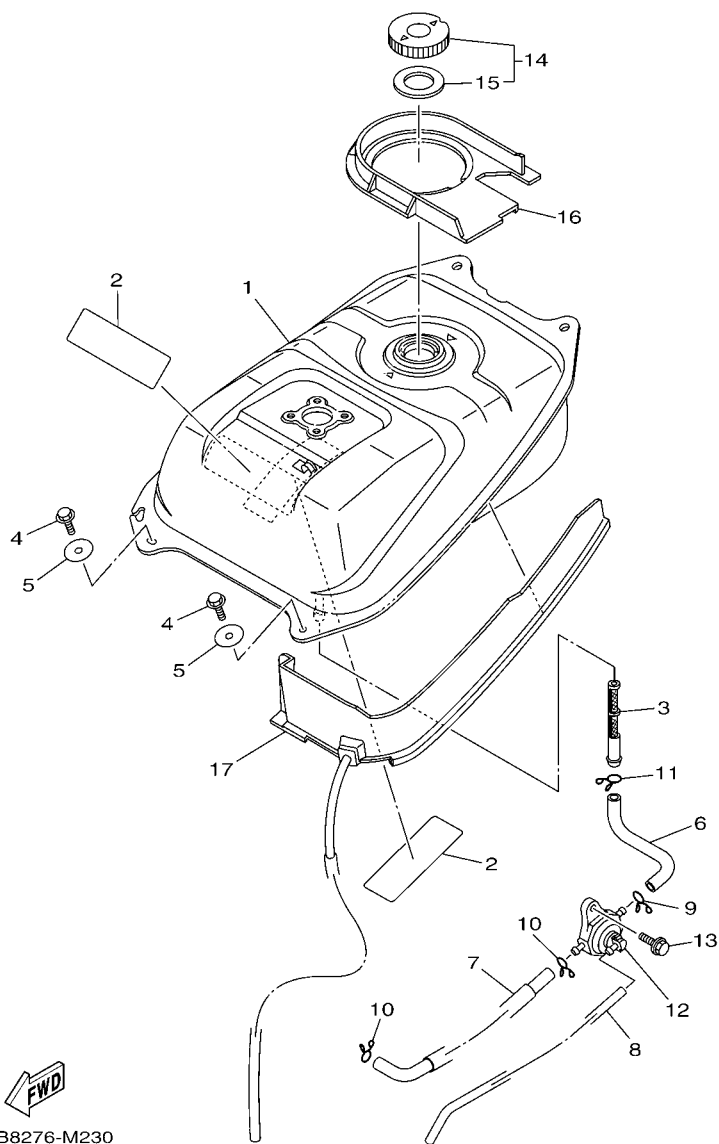

40B8276-M230

REF. N°	CODIGO N° PART NO.	DESCRIPCION DESCRIPTION	40B8				OBSERVACIONES REMARKS
1	4S9-F4110-02	DEPOSITO DE COMBUSTIBLE COMP. FUEL TANK COMP.	1				
2	4S9-F414G-11	SELLO SEAL	2				
3	4S9-F4514-00	RED DE FILTRO 1 NET, FILTER 1	1				
4	95822-06016	TORNILLO DE REBORDE BOLT, FLANGE	2				
5	90201-06816	ARANDELA PLANA WASHER, PLATE	2				
6	4S9-F4311-00	TUBO DE COMBUSTIBLE 1 PIPE, FUEL 1	1				
7	4S9-F4312-10	TUBO 2 PIPE 2	1				
8	4S9-F4313-00	TUBO 3 PIPE 3	1				
9	90467-10803	PRESILLA CLIP	1				
10	90467-09006	PRESILLA CLIP	2				
11	90467-11801	PRESILLA CLIP	1				
12	4S9-F4500-01	GRIFO DE COMBUSTIBLE 1 FUEL COCK ASSY 1	1				
13	95802-06014	TORNILLO DE REBORDE BOLT, FLANGE	1				
14	4S9-F4610-01	TAPA COMPLETA CAP ASSY	1				
15	4S9-F4612-01	.EMPAQUE DE TAPA .PACKING, CAP	1				
16	4S9-F4141-00	PROTECTOR DEPOSITO COMBUST. PROTECTOR, FUEL TANK	1				
17	4S9-F4188-01	MOLDURA DEPOSITO COMBUST. MOLD, FUEL TANK	1				

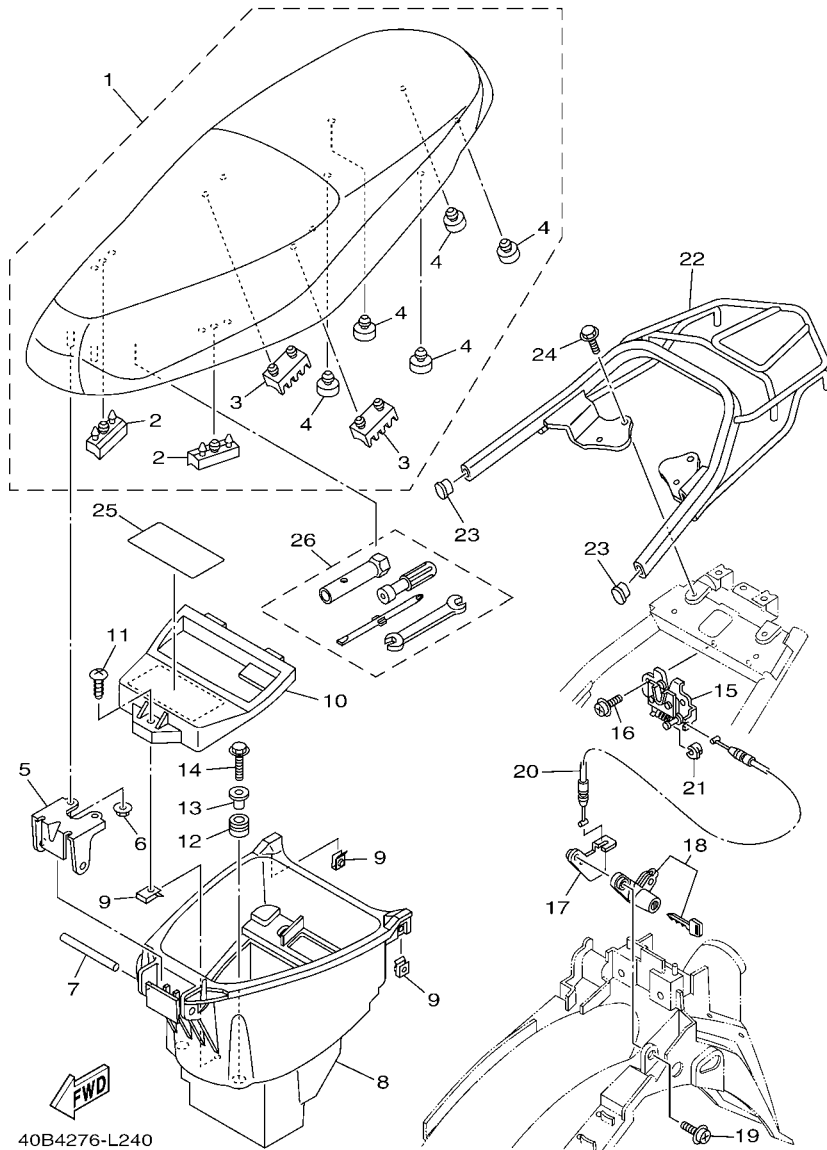

40B4276-L240

FIG. 24 ASIENTO

SEAT

REF. N°	CODIGO N° PART NO.	DESCRIPCION DESCRIPTION	4088				OBSERVACIONES REMARKS
1	4S9-F4730-10	SILLIN DOBLE COMPLETO DOUBLE SEAT ASSY	1				
2	4S9-F4747-00	.AMORTIGUADOR DE ASIENTO .DAMPER, SEAT	2				
3	4S9-F4723-00	.AMORTIGUADOR DE ASIENTO .DAMPER, SEAT	2				
4	4S9-F4741-00	.COJIN DE ASIENTO .PAD, SEAT	5				
5	4S9-F4726-00	HINGE SEAT HINGE, SEAT	1				
6	95702-06500	TUERCA DE BRIDA NUT, FLANGE	2				
7	4S9-F4727-00	PASADOR ACCESORIO DE ASIENTO PIN, SEAT FITTING	1				
8	4S9-F473R-00	CAJA 1 BOX 1	1				
9	90183-05807	TUERCA DE RESORTE NUT, SPRING	3				
10	4S9-F473T-00	TAPA 1 LID 1	1				
11	97702-50016	TORNILLO ROSCA HEMBRA SCREW, TAPPING	1				
12	90480-14806	TAPON GROMMET	4				
13	90387-068K6	ESPACIADOR COLLAR	4				
14	95022-06025	PERNO, DE BRIDA BOLT, FLANGE	4				
15	4S9-F4780-00	CERRADURA SILLIN COMPLETO SEAT LOCK ASSY	1				
16	98502-06012	TORNILLO SCREW, PAN HEAD	2				
17	4S9-F117K-00	SOPORTE DE CERRADURA STAY, LOCK	1				
18	4S9-WF470-00	JUEGO DE ROTOR ROTOR SET	1				
19	90159-06867	TORNILLO CON VALONA SCREW, WITH WASHER	1				
20	4S9-F478E-00	CABLE CABLE, SEAT LOCK	1				
21	4S9-F4768-00	TOPE STOPPER	1				
22	4S9-F4773-01	MANIJA DE ASIENTO HANDLE, SEAT	1				
23	4S9-F4742-00	ANILLO PROTECTOR GROMMET	2				
24	95812-06020	TORNILLO DE REBORDE BOLT, FLANGE	4				
25	40B-F4875-10	ETIQUETA 1 LABEL 1	1				
26	4S9-F8100-00	JUEGO DE HERRAMIENTAS TOOL KIT	1				

FIG. 25 RUEDA DELANTERA

FRONT WHEEL

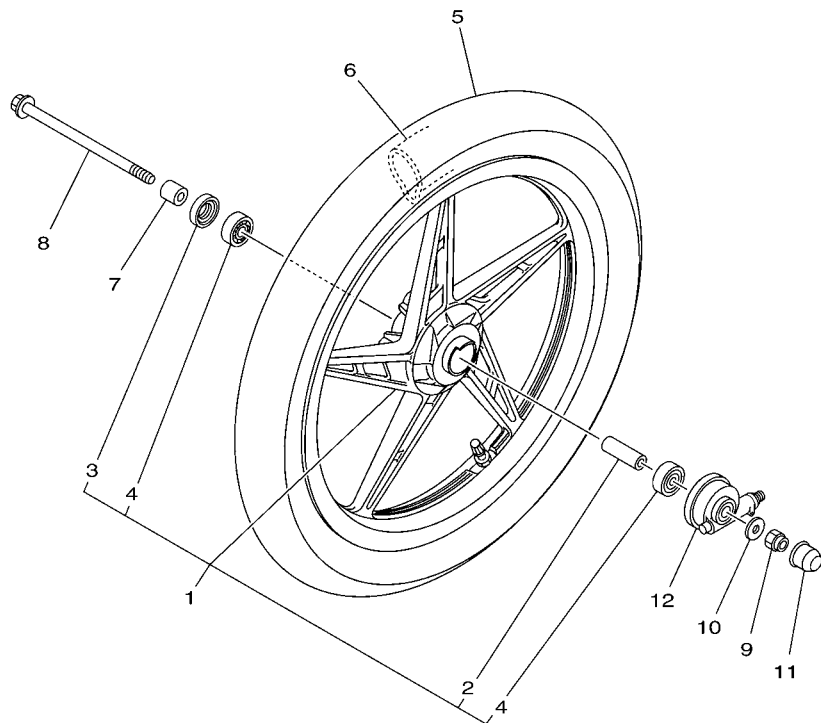

FWD
40B1516-G250

REF. Nº	CODIGO Nº PART NO.	DESCRIPCION DESCRIPTION	40B8			OBSERVACIONES REMARKS
1	4S9-F5160-30-WN	RUEDA FUNDIDA DELANTERA CAST WHEEL, FRONT	1			CIS CIS
2	90560-10292	.SEPARADOR .SPACER	1			
3	93106-20826	.SELLO ACEITE .OIL SEAL	1			
4	93306-300Y4	.COJINETE .BEARING	2			
5	94107-17842	NEUMATICO (70/90-17 M/C 38H) TIRE (70/90-17 M/C 38H HF314A)	1			DURO DURO
6	94207-17808	TUBO (2.50/2.75, 70-80/90-17) TUBE (2.50/2.75, 70-80/90-17)	1			DURO DURO
7	90387-10828	ESPACIADOR COLLAR	1			
8	4S9-F5181-00	EJE DE LA RUEDA AXLE, WHEEL	1			
9	90185-10807	TUERCA AUTOBLOCANTE NUT, SELF-LOCKING	1			
10	90201-10831	ARANDELA PLANA WASHER, PLATE	1			
11	40B-F5188-00	TAPA CAP	1			
12	4S9-F5190-10	UNIDAD DE ENGRANAJE COMPLETA GEAR UNIT ASSY	1			

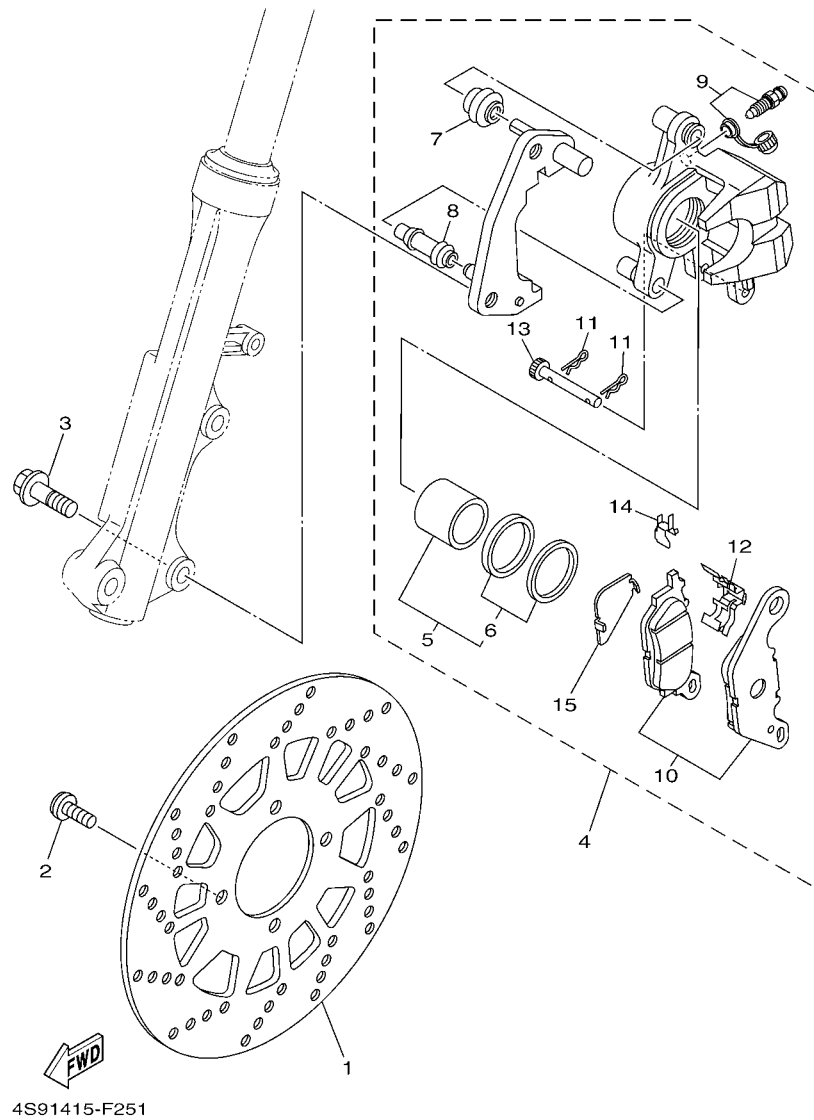

FIG. 26 CALIBRE FRENO DELANTERA FRONT BRAKE CALIPER

REF. N°	CODIGO N° PART NO.	DESCRIPCION DESCRIPTION	4088				OBSERVACIONES REMARKS
1	40B-F582U-00	DISCO DE FRENO (DERECHO) DISK, BRAKE (RIGHT)	1				
2	90111-08853	TORNILLO BOLT, HEX. SOCKET BUTTON	4				
3	90105-10824	TORNILLO BOLT, FLANGE	2				
4	4S9-F580U-01	CALIBRE COMPLETO (DERECHO) CALIPER ASSY (RIGHT)	1				
5	4S5-W0057-00	.PISTON COMPLETO PINZA .PISTON ASSY, CALIPER	1				
6	4S5-W0047-00	..JUEGO DE RETENES DE PINZA ..CALIPER SEAL KIT	1				
7	4S5-F5917-00	.FUNDA DE CALIBRE .BOOT, CALIPER	1				
8	4S5-F5937-00	.FUNDA .BOOT 2	1				
9	4S5-W0048-01	.CJTO TORNILLO DE PURGA .BLEED SCREW KIT	1				
10	4S5-W0045-00	.JUEGO DE COJIN DE FRENO .BRAKE PAD KIT	1				
11	4S5-F5925-00	.PRESILLA .CLIP	2				
12	4S5-F5919-00	.SOPORTE DE PASTILLAS .SUPPORT, PAD	1				
13	4S5-F5924-01	.PASADOR .PIN, PAD	1				
14	4S5-F5939-00	.PRESILLA .CLIP, PAD	1				
15	4S9-F5827-00	.CUNA DE CALIBRE .SHIM, CALIPER	1				

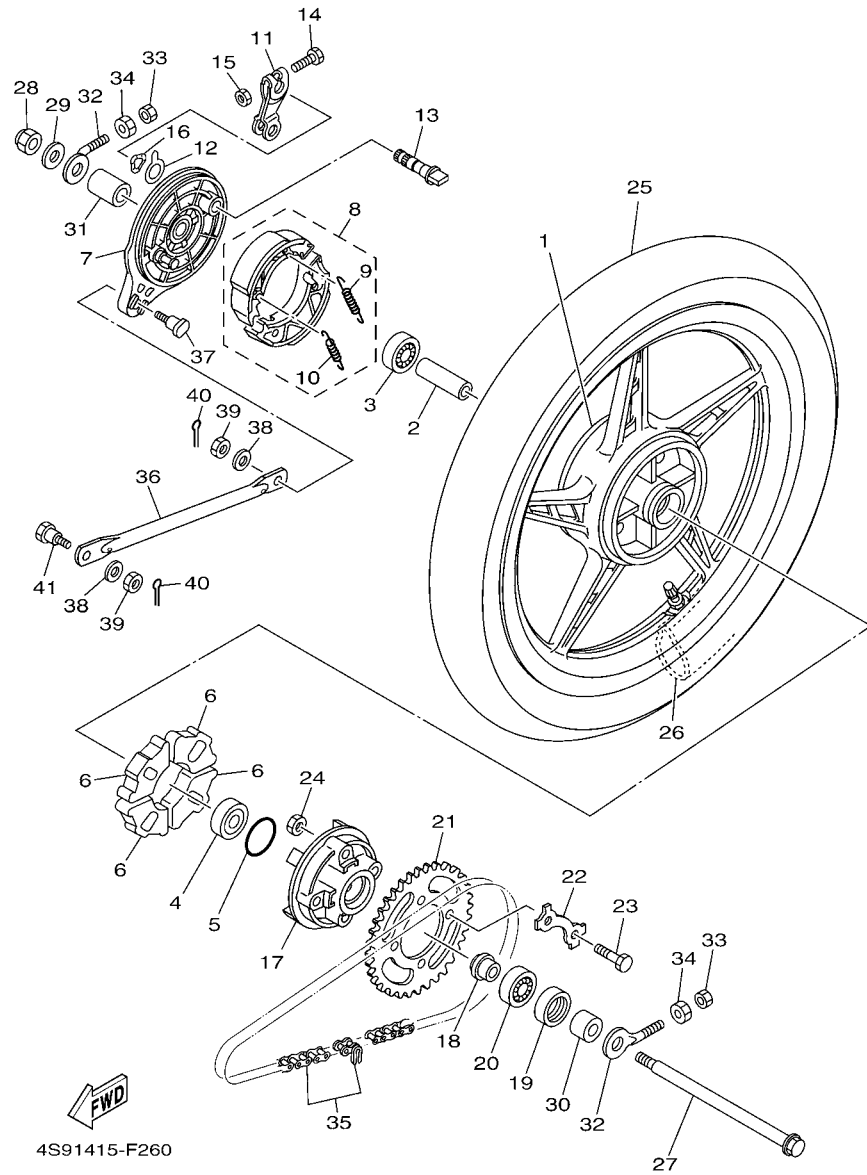

FIG. 27 RUEDA TRASERA

REAR WHEEL

REF. Nº	CODIGO Nº PART NO.	DESCRIPCION DESCRIPTION	4088				OBSERVACIONES REMARKS
1	4S9-F5338-00-WN	RUEDA FUNDIDA TRASERA CAST WHEEL, REAR	1				CIS CIS
2	90387-12844	ESPACIADOR COLLAR	1				
3	93306-301XG	COJINETE BEARING	1				
4	93306-301XH	COJINETE BEARING	1				
5	93210-41041	ANILLO O O-RING	1				
6	4S9-F5364-00	AMORTIGUADOR DAMPER	4				
7	4S9-F5321-00-WN	PLACA DE ZAPATA DE FRENO PLATE, BRAKE SHOE	1				CIS CIS
8	4S9-WF530-00	JUEGO DE ZAPATA DE FRENO BRAKE SHOE SET	1				
9	90506-12801	.RESORTE DE TENSION .SPRING, TENSION	1				
10	90506-15802	.RESORTE DE TENSION .SPRING, TENSION	1				
11	4S9-F5355-00	PALANCA DE ARBOL DE LEVAS LEVER, CAMSHAFT	1				
12	4S9-F533A-00	PLACA INDICADOR PLATE, INDICATOR	1				
13	4S9-F5351-00	ARBOL DE LEVAS CAMSHAFT	1				
14	90101-06818	TORNILLO BOLT	1				
15	95302-06600	TUERCA NUT	1				
16	90206-14093	ARANDELA ONDULADA WASHER, WAVE	1				
17	4S9-F5366-00-WN	EMBRAGUE DE MASA CLUTCH, HUB	1				CIS CIS
18	93106-26823	SELLO ACEITE OIL SEAL	1				
19	90387-127Y0	ESPACIADOR COLLAR	1				
20	93306-054Y0	COJINETE BEARING	1				
21	4S9-F5435-20	CORONA (35T) SPROCKET, DRIVEN (35T)	1				
22	4S9-F5412-00	ARANDELA WASHER	2				
23	90101-08847	TORNILLO BOLT	4				
24	90179-08639	TUERCA NUT	4				
25	94108-17841	NEUMATICO (80/90-17 M/C 50P) TIRE (80/90-17 M/C 50P HF314A)	1				DURO DURO DURO
26	94207-17808	TUBO (2.50/2.75, 70-80/90-17) TUBE (2.50/2.75, 70-80/90-17)	1				DURO DURO
27	4S9-F5381-00	EJE DE RUEDA AXLE, WHEEL	1				

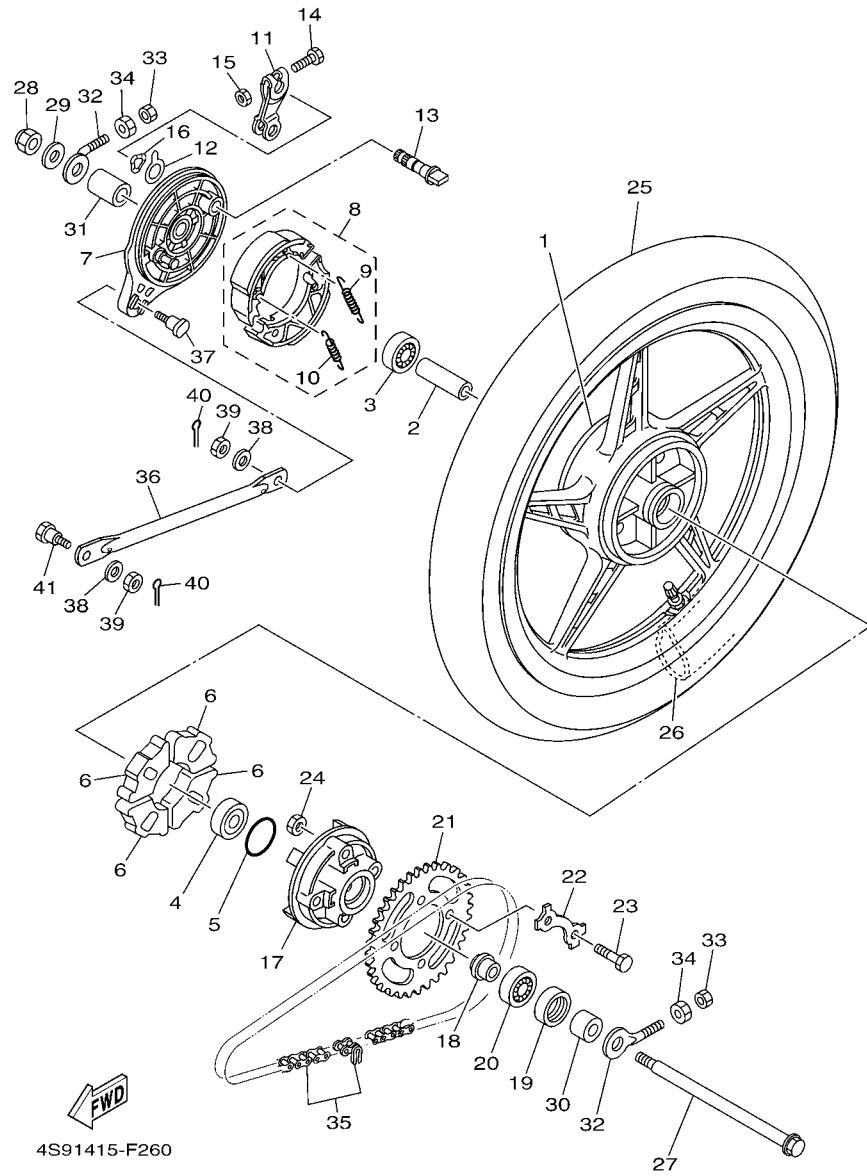
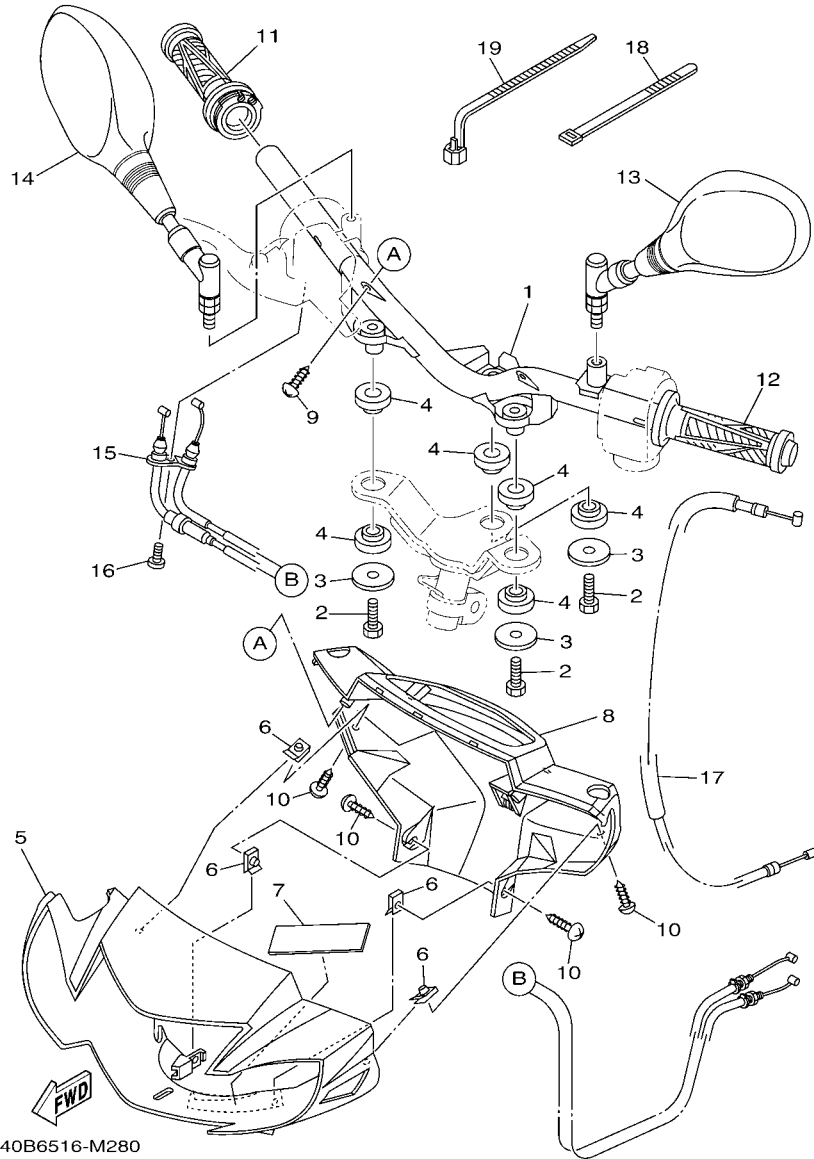

FIG. 27 RUEDA TRASERA

REAR WHEEL

REF. Nº	CODIGO Nº PART NO.	DESCRIPCION DESCRIPTION	4088				OBSERVACIONES REMARKS
28	90185-12804	TUERCA AUTOBLOCANTE NUT, SELF-LOCKING	1				
29	90201-12826	ARANDELA PLANA WASHER, PLATE	1				
30	4S9-F5383-00	COLLAR DE RUEDA COLLAR, WHEEL	1				
31	90387-12841	ESPACIADOR COLLAR	1				
32	4S9-F5389-00	TIRADOR DE CADENA 2 PULLER, CHAIN 2	2				
33	95307-06600	TUERCA NUT	2				
34	90170-06809	TUERCA NUT	2				
35	94568-B7098	CADENA CHAIN	1				
36	4S9-F5371-00	BARRA TENSORA BAR, TENSION	1				
37	90109-08816	PERNO BOLT	1				
38	92902-08200	ARANDELA WASHER	2				
39	95302-08700	TUERCA NUT	2				
40	91402-20012	CHAVETA PIN, COTTER	2				
41	90109-08848	PERNO BOLT	1				



40B6516-M280

FIG. 28 MANILLAR & CABLE

STEERING HANDLE & CABLE

REF. N°	CODIGO N° PART NO.	DESCRIPCION DESCRIPTION	40B8				OBSERVACIONES REMARKS
1	4S9-F6210-01	MANUBRIO HANDLE	1				
2	97002-08016	PERNO BOLT	3				
3	90201-088C4	ARANDELA PLANA WASHER, PLATE	3				
4	4S9-F6113-00	AMORTIGUADOR DAMPER	6				
5	4S9-F6143-01-P0	CUBIERTA DE MANUBRIO SUPERIOR1 COVER,HAND,UPPER 1	1				UR PARA DRMK UR FOR DRMK
	4S9-F6143-01-P2	CUBIERTA DE MANUBRIO SUPERIOR1 COVER,HAND,UPPER 1	1				UR PARA SMX UR FOR SMX
	4S9-F6143-01-P3	CUBIERTA DE MANUBRIO SUPERIOR1 COVER,HAND,UPPER 1	1				UR PARA DPBMC UR FOR DPBMC
6	90183-05807	TUERCA DE RESORTE NUT, SPRING	4				
7	4S9-F6113-20	AMORTIGUADOR DAMPER	1				
8	4S9-F6145-00	CUBIERTA DE MANUBRIO SUPERIOR2 COVER, HAND UPPER 2	1				
9	97702-50016	TORNILLO ROSCA HEMBRA SCREW, TAPPING	2				
10	97702-50012	TORNILLO ROSCA HEMBRA SCREW, TAPPING	4				
11	40B-F6240-10	EMPUNADURA COMPLETA GRIP ASSY	1				
12	4S9-F6241-00	EMPUNADURA GRIP	1				
13	40B-F6280-00	ESPEJO COMPLETO (IZQUIERDO) REAR VIEW MIRROR ASSY (LEFT)	1				
14	40B-F6290-00	ESPEJO COMPLETO (DERECHO) REAR VIEW MIRROR ASSY (RIGHT)	1				
15	40B-F6301-00	CABLE DE ACELERADOR COMPLETO THROTTLE CABLE ASSY	1				
16	98502-05012	TORNILLO SCREW, PAN HEAD	1				
17	4S9-F6331-00	CABLE DE ARRANQUE CABLE, STARTER 1	1				
18	4S9-H3936-00	BANDA DE CABLE DE INTERRUPTOR BAND, SWITCH CORD	2				
19	90464-45800	BRIDA CLAMP	1				

FIG. 29 CILINDRO MAESTRO DELANTERO FRONT MASTER CYLINDER

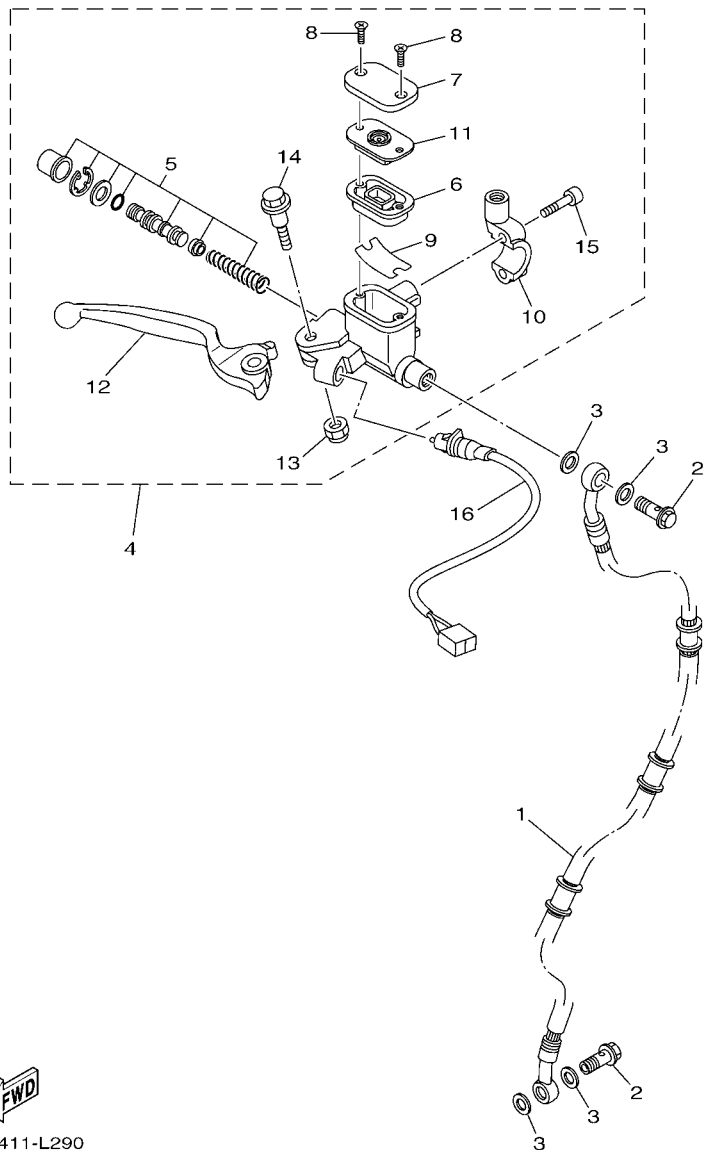

1SX1411-L290

REF. Nº	CODIGO Nº PART NO.	DESCRIPCION DESCRIPTION	4088				OBSERVACIONES REMARKS
1	4S9-F5872-01	MANGUERA DE FRENO 1 HOSE, BRAKE 1	1				
2	90401-10823	PERNO DE UNION BOLT, UNION	2				
3	90201-108J9	ARANDELA PLANA WASHER, PLATE	4				
4	4S9-F583T-01	CILINDRO MAESTRO COMPLETO MASTER CYLINDER ASSY	1				
5	4S9-W0041-01	JUEGO DE CILINDRO MAESTRO CYLINDER KIT, MASTER	1				
6	4S9-F5854-00	EMPAQUE, DIAFRAGMA DIAPHRAGM, RESERVOIR	1				
7	4S9-F5852-00	TAPA DE TANQUE DE RESERVA CAP, RESERVOIR	1				
8	4KL-F589H-01	TORNILLO SCREW	2				
9	4KL-F5896-00	PLACA DEP. DE RESERVA PLATE, RESERVOIR	1				
10	4S9-F5867-00	SOPORTE DE CILINDRO MAESTRO BRACKET, MASTER CYLINDER	1				
11	4S9-F5855-00	BUJE DE DIAFRAGMA BUSH, DIAFRAGM	1				
12	4S9-H3922-00	PALANCA 2 LEVER 2	1				
13	3D9-F586F-01	TUERCA AUTOBLOCANTE NUT, U	1				
14	3D9-F589F-01	PERNO DE PALANCA BOLT, LEVER	1				
15	91312-06025	TORNILLO BOLT	2				
16	4S9-H3980-01	INTERRUP. DE PARADA DELANTERO FRONT STOP SWITCH ASSY	1				

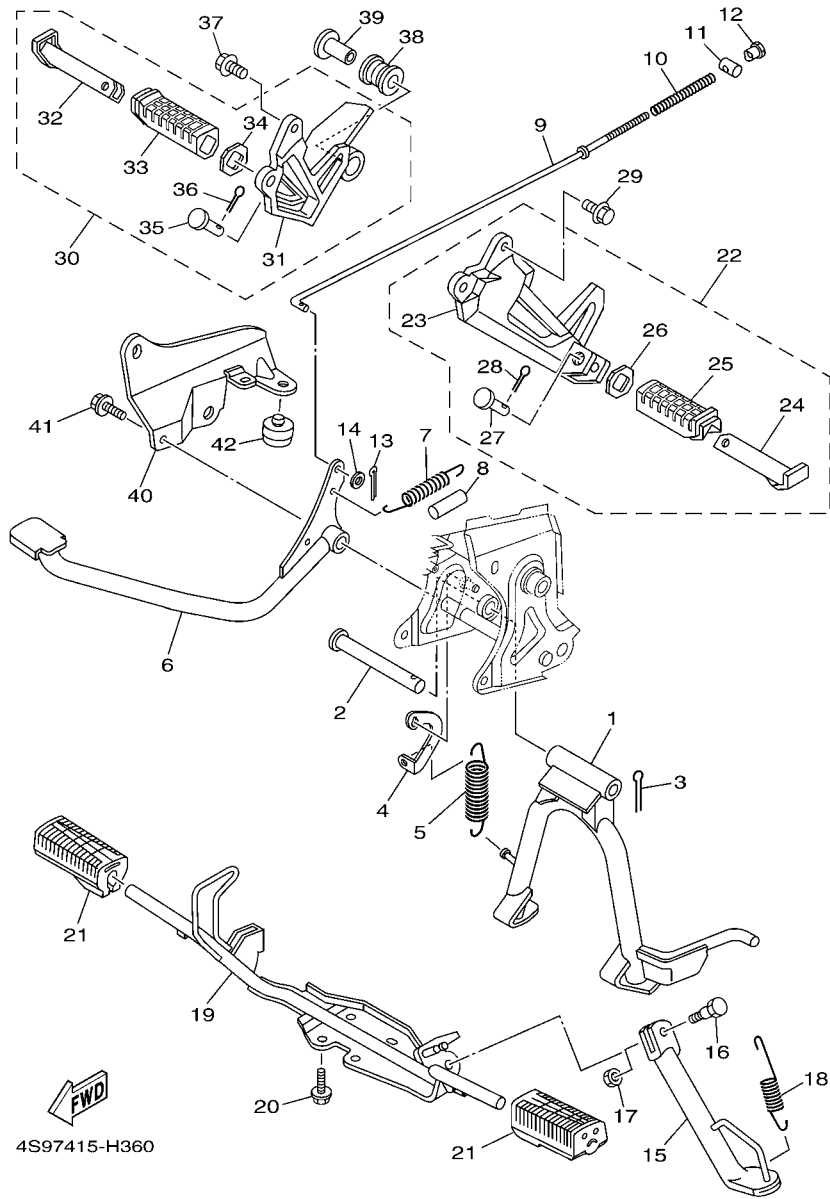

FIG. 30 SOPORTE & APOYAPIE

STAND & FOOTREST

REF. Nº	CODIGO Nº PART NO.	DESCRIPCION DESCRIPTION	4088				OBSERVACIONES REMARKS
1	4S9-F7111-01	PUNTAL PRINCIPAL STAND, MAIN	1				
2	4S9-F7112-00	EJE DE PUNTAL PRINCIPAL SHAFT, MAIN STAND	1				
3	91402-30030	CHAVETA PIN, COTTER	1				
4	4S9-F7115-00	CONEXION DE PUNTAL PRINCIPAL LINK, MAIN STAND	1				
5	90506-35815	RESORTE DE TENSION SPRING, TENSION	1				
6	4S9-F7211-00	PEDAL DE FRENO PEDAL, BRAKE	1				
7	90506-20810	RESORTE DE TENSION SPRING, TENSION	1				
8	4S9-F7235-00	CUBIERTA DE POLVO COVER, DUST	1				
9	4S9-F7231-00	VARILLA DE FRENO ROD, BRAKE	1				
10	90501-10245	RESORTE DE COMPRESION SPRING, COMPRESSION	1				
11	90249-12008	PASADOR PIN	1				
12	90179-06835	TUERCA NUT	1				
13	91402-20012	CHAVETA PIN, COTTER	1				
14	92907-06600	ARANDELA WASHER, PLATE	1				
15	4S9-F7311-00	PUNTAL LATERAL STAND, SIDE	1				
16	90109-08830	PERNO BOLT	1				
17	90185-08818	TUERCA AUTOBLOCANTE NUT, SELF-LOCKING	1				
18	90506-20829	RESORTE DE TENSION SPRING, TENSION	1				
19	4S9-F7411-00	APOYAPIE 1 FOOTREST 1	1				
20	95822-08016	TORNILLO DE REBORDE BOLT, FLANGE	4				
21	4S9-F7413-00	CUBIERTA DE APOYAPIE COVER, FOOTREST	2				
22	4S9-F7430-01	APOYAPIE POSTERIOR COMPLETO 1 REAR FOOTREST ASSY 1	1				
23	4S9-F7452-00-WN	SOPORTE, DE APOYAPIE 1 BRACKET, FOOTREST 1	1				CIS CIS
24	4S9-F7431-01	APOYAPIE POSTERIOR 1 FOOTREST, REAR 1	1				
25	4S9-F7433-00	CUBIERTA APOYAPIE TRASERO COVER, REAR FOOTREST	1				
26	4S9-F7445-01	PLACA 1 PLATE 1	1				
27	91702-08042	PASADOR DE ADRAZADERA PIN, CLEVIS	1				

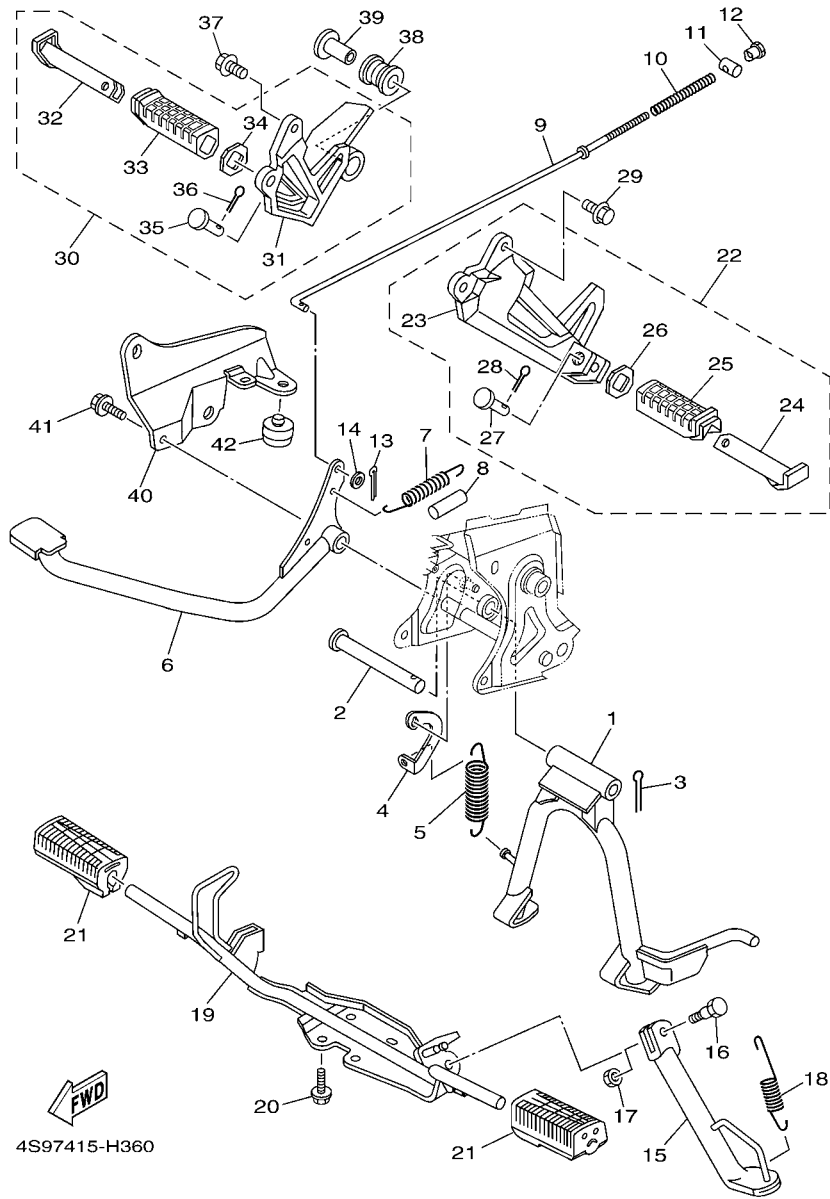
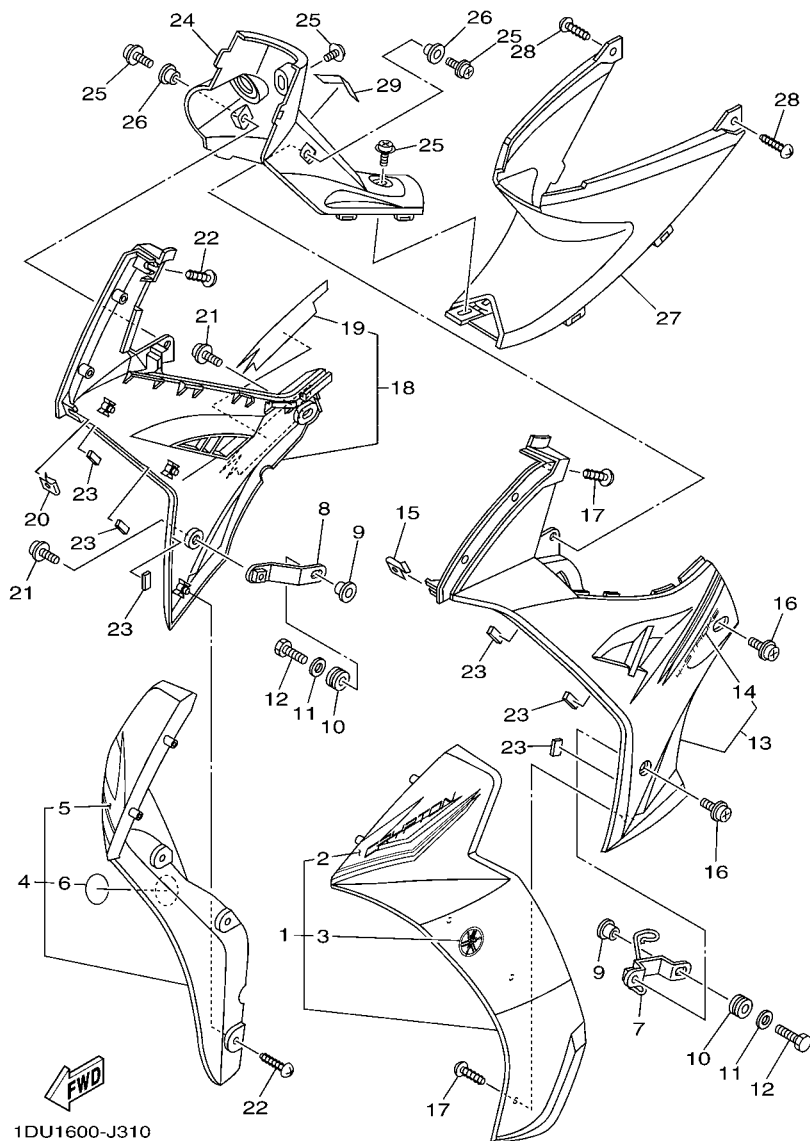

FIG. 30 SOPORTE & APOYAPIE

STAND & FOOTREST

REF. Nº	CODIGO Nº PART NO.	DESCRIPCION DESCRIPTION	4038			OBSERVACIONES REMARKS
28	91402-25015	.CHAVETA .PIN, COTTER	1			
29	95812-08020	TORNILLO DE REBORDE BOLT, FLANGE	2			
30	4S9-F7440-01	APOYAPIE POSTERIOR COMPLETO 2 REAR FOOTREST ASSY 2	1			
31	4S9-F7462-00-WN	.SOPORTE, DE APOYAPIE 2 .BRACKET, FOOTREST 2	1			CIS CIS
32	4S9-F7441-01	.APOYAPIE POSTERIOR 2 .FOOTREST, REAR 2	1			
33	4S9-F7444-00	.CUBIERTA APOYAPIE TRASERO .COVER, REAR FOOTREST	1			
34	4S9-F7445-01	.PLACE 1 .PLATE 1	1			
35	91702-08042	.PASADOR DE ADRAZADERA .PIN, CLEVIS	1			
36	91402-25015	.CHAVETA .PIN, COTTER	1			
37	95812-08020	TORNILLO DE REBORDE BOLT, FLANGE	2			
38	4S9-F7424-00	AMORTIGUADOR DE APOYAPIE 2 DAMPER, FOOTREST 2	1			
39	90387-10817	ESPACIADOR COLLAR	1			
40	4S9-F194J-01	SUPORTE DO SILENCIADOR STAY, MUFFLER	1			
41	95822-08016	TORNILLO DE REBORDE BOLT, FLANGE	1			
42	4S9-F4763-00	COJIN DE ASIENTO 2 PAD, SEAT 2	1			



1DU1600-J310

FIG. 31 PATA PROTEGIDA

LEG SHIELD

REF. Nº	CODIGO Nº PART NO.	DESCRIPCION DESCRIPTION	4088			OBSERVACIONES REMARKS
1	4S9-XF831-10-P0	PROTECCION DE PATA 1 LEG SHIELD 1	1			UR PARA DRMK UR FOR DRMK
	4S9-XF831-10-P1	PROTECCION DE PATA 1 LEG SHIELD 1	1			UR PARA SMX UR FOR SMX
	4S9-XF831-10-P3	PROTECCION DE PATA 1 LEG SHIELD 1	1			UR PARA DPBMC UR FOR DPBMC
2	4S9-F8391-30	.CALCOMANIA 1 .GRAPHIC 1	1			UR PARA DRMK UR FOR DRMK
	4S9-F8391-40	.CALCOMANIA 1 .GRAPHIC 1	1			UR PARA SMX UR FOR SMX
	4S9-F8391-50	.CALCOMANIA 1 .GRAPHIC 1	1			UR PARA DPBMC UR FOR DPBMC
3	4S9-F411B-00	.EMBLEMA .EMBLEM	1			
4	4S9-XF832-30-P0	PROTECCION DE PATA 2 LEG SHIELD 2	1			UR PARA DRMK UR FOR DRMK
	4S9-XF832-30-P1	PROTECCION DE PATA 2 LEG SHIELD 2	1			UR PARA SMX UR FOR SMX
	4S9-XF832-30-P3	PROTECCION DE PATA 2 LEG SHIELD 2	1			UR PARA DPBMC UR FOR DPBMC
5	4S9-F8392-30	.CALCOMANIA 2 .GRAPHIC 2	1			UR PARA DRMK UR FOR DRMK
	4S9-F8392-40	.CALCOMANIA 2 .GRAPHIC 2	1			UR PARA SMX UR FOR SMX
	4S9-F8392-50	.CALCOMANIA 2 .GRAPHIC 2	1			UR PARA DPBMC UR FOR DPBMC
6	4S9-F411B-00	.EMBLEMA .EMBLEM	1			
7	4S9-F8321-01	SOPORTE STAY 1	1			
8	4S9-F8322-01	SOPORTE 2 STAY 2	1			
9	90387-06814	ESPACIADOR COLLAR	2			
10	90480-13018	TAPON GROMMET	2			
11	90201-06557	ARANDELA PLANA WASHER, PLATE	2			
12	97002-06020	PERNO BOLT	2			
13	4S9-XF838-10-P0	CUBIERTA INFERIOR COVER, UNDER	1			UR SMX PARA DRMK UR SMX FOR DRMK
	4S9-XF838-10-P1	CUBIERTA INFERIOR COVER, UNDER	1			UR BS4 PARA SMX UR BS4 FOR SMX
	4S9-XF838-10-P3	CUBIERTA INFERIOR COVER, UNDER	1			UR PARA DPBMC UR FOR DPBMC
14	4S9-F8398-30	.GRAFICO 5 .GRAPHIC 5	1			UR PARA DRMK UR FOR DRMK
	4S9-F8398-40	.GRAFICO 5 .GRAPHIC 5	1			UR PARA SMX UR FOR SMX
	4S9-F8398-50	.GRAFICO 5 .GRAPHIC 5	1			UR PARA DPBMC UR FOR DPBMC
15	90183-05807	TUERCA DE RESORTE NUT, SPRING	1			

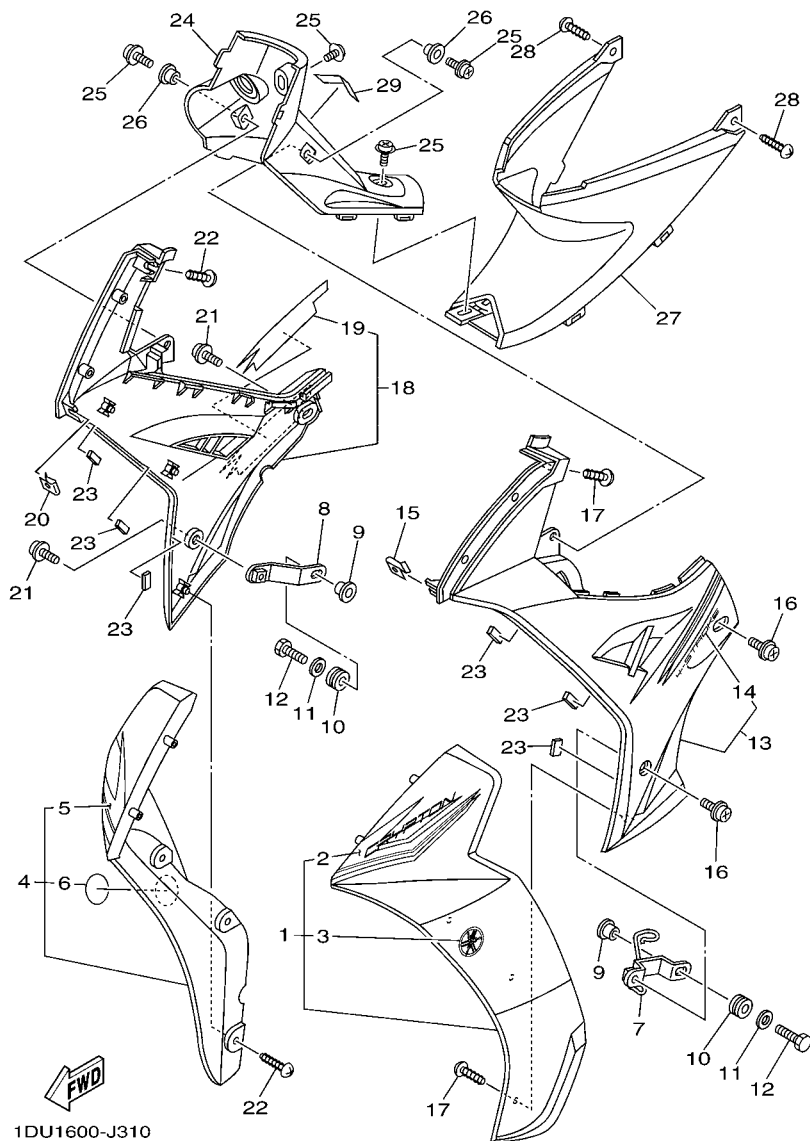

FIG. 31 PATA PROTEGIDA

LEG SHIELD

REF. Nº	CODIGO Nº PART NO.	DESCRIPCION DESCRIPTION	4088				OBSERVACIONES REMARKS
16	90159-06842	TORNILLO CON VALONA SCREW, WITH WASHER	2				
17	97702-50012	TORNILLO ROSCA HEMBRA SCREW, TAPPING	6				
18	4S9-XF839-10-P0	CUBIERTA INFERIOR 2 COVER, UNDER 2	1				UR SMX PARA DRMK UR SMX FOR DRMK
	4S9-XF839-10-P1	CUBIERTA INFERIOR 2 COVER, UNDER 2	1				UR BS4 PARA SMX UR BS4 FOR SMX
	4S9-XF839-10-P3	CUBIERTA INFERIOR 2 COVER, UNDER 2	1				UR PARA DPBMC UR FOR DPBMC
19	4S9-F8399-30	.CALCOMANIA 6 .GRAPHIC 6	1				UR PARA DRMK UR FOR DRMK
	4S9-F8399-40	.CALCOMANIA 6 .GRAPHIC 6	1				UR PARA SMX UR FOR SMX
	4S9-F8399-50	.CALCOMANIA 6 .GRAPHIC 6	1				UR PARA DPBMC UR FOR DPBMC
20	90183-05807	TUERCA DE RESORTE NUT, SPRING	1				
21	90159-06842	TORNILLO CON VALONA SCREW, WITH WASHER	2				
22	97702-50012	TORNILLO ROSCA HEMBRA SCREW, TAPPING	6				
23	4S9-F8371-00	AMORTIGUADOR DAMPER	6				
24	4S9-F842M-00	CUBIERTA 1 COVER 1	1				
25	90159-06842	TORNILLO CON VALONA SCREW, WITH WASHER	4				
26	90387-068E9	ESPACIADOR COLLAR	2				
27	4S9-F842N-00	CUBIERTA 2 COVER 2	1				
28	97702-50016	TORNILLO ROSCA HEMBRA SCREW, TAPPING	2				
29	40B-F1568-S0	ETIQUETA DE PRECAUCION LABEL, WARNING	1				

FIG. 32 GENERADOR

GENERATOR

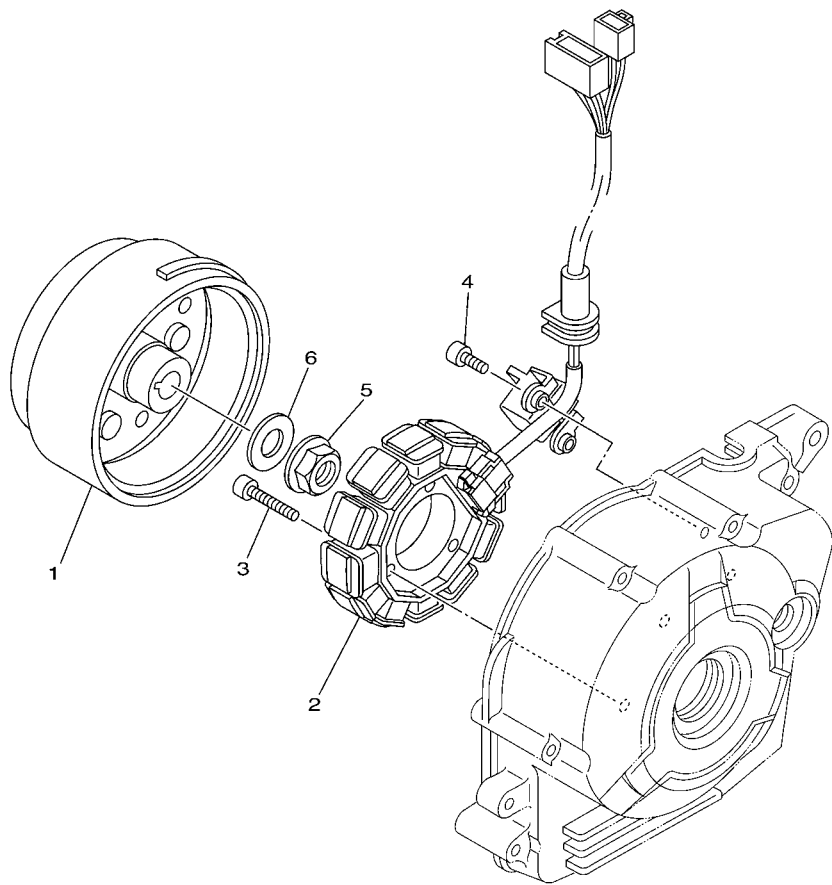

REF. Nº	CODIGO Nº PART NO.	DESCRIPCION DESCRIPTION	4088				OBSERVACIONES REMARKS
1	4S9-H1450-00	ROTOR COMPLETO ROTOR ASSY	1				
2	40B-H1410-00	ESTATOR COMPLETO STATOR ASSY	1				
3	91312-06025	TORNILLO BOLT	3				
4	91312-06014	TORNILLO BOLT	2				
5	95702-12500	TUERCA DE BRIDA NUT, FLANGE	1				
6	90201-12030	ARANDELA PLANA WASHER, PLATE	1				



5TN1431-B320

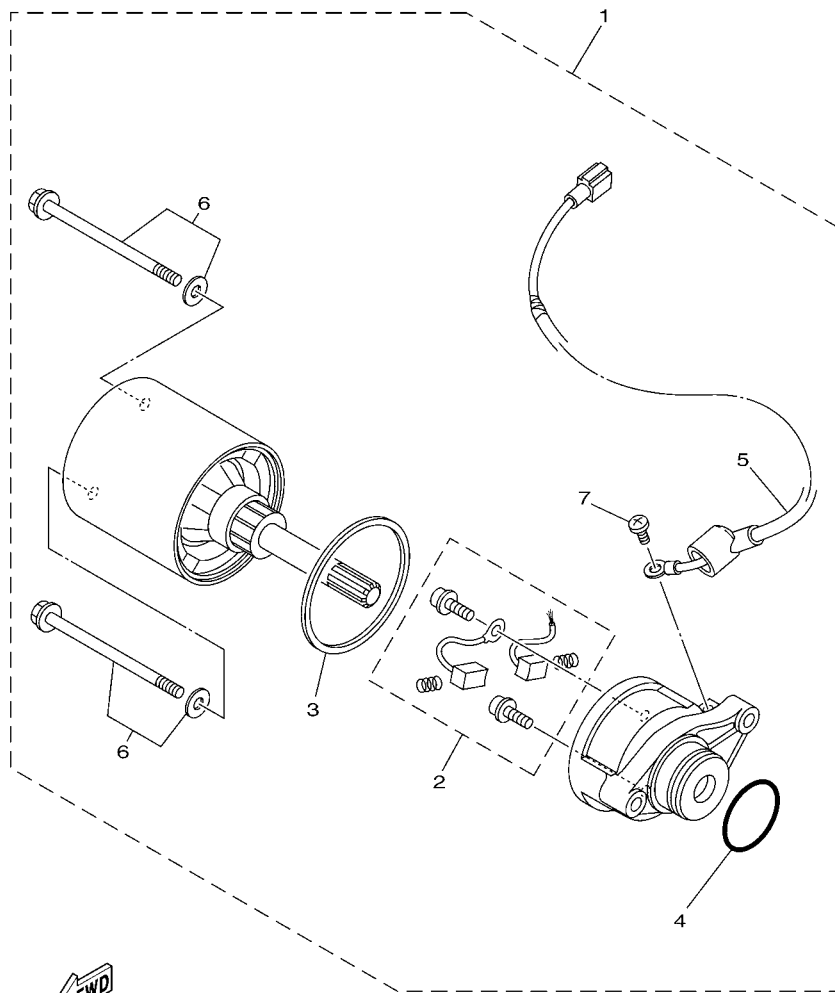

40B4276-L330

FIG. 33 MOTOR DE ARRANQUE

STARTING MOTOR

REF. N°	CODIGO N° PART NO.	DESCRIPCION DESCRIPTION	40B8				OBSERVACIONES REMARKS
1	4S9-H1800-20	MOTOR DE ARRANQUE COMPLETO STARTING MOTOR ASSY	1				
2	4S9-H1801-10	.JUEGO DE ESCOBILLA .BRUSH SET	1				
3	4S9-H1847-00	.ANILLO GOMA .O-RING	1				
4	93210-23614	.ANILLO O .O-RING	1				
5	4S9-H183G-10	.CABLE DEL MOTOR COMPL. .CORD COMPL.	1				
6	4S9-H1828-00	.TORNILLO DE EMPUJE 2 .SCREW 2	2				
7	4S9-E1846-00	.TORNILLO, 1 .SCREW, 1	1				

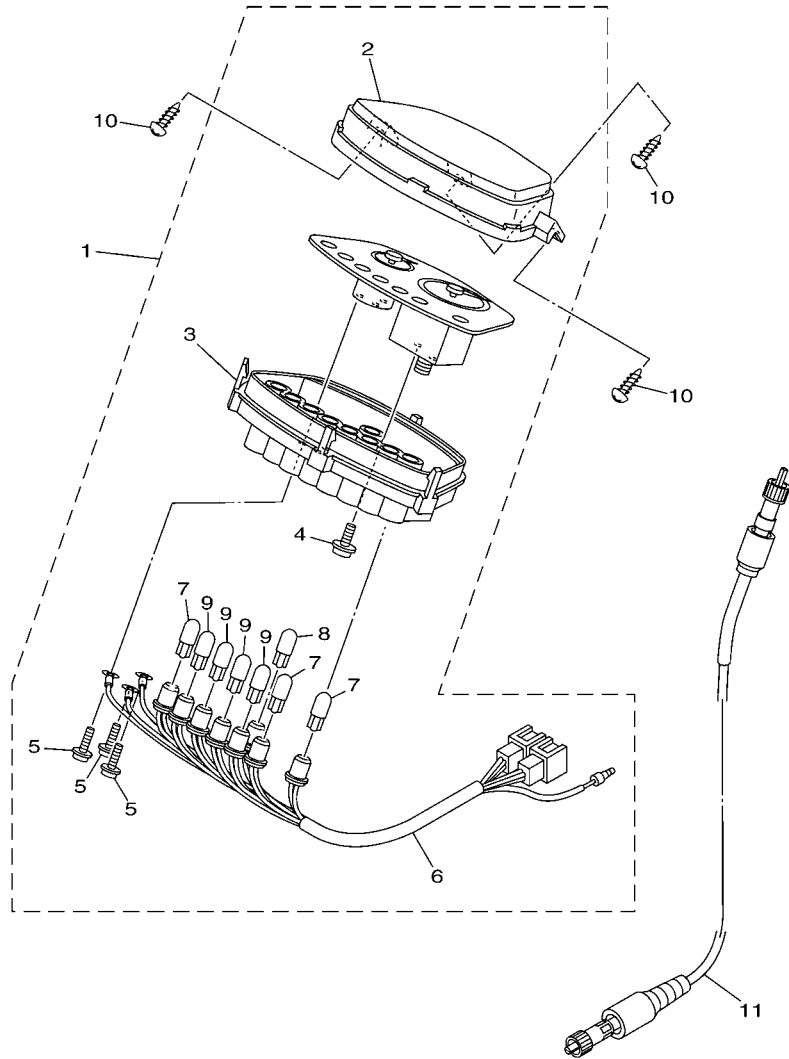

FWD
4S97415-H420

FIG. 35 MEDIDOR

METER

REF. N°	CODIGO N° PART NO.	DESCRIPCION DESCRIPTION	4088				OBSERVACIONES REMARKS
1	4S9-H3510-01	VELOCIMETRO COMPL. SPEEDOMETER ASSY	1				
2	4S9-H3511-00	.LENTE DE VELOCIMETRO .LENS, SPEEDOMETER	1				
3	4S9-H353F-00	.CAJA DE MEDIDOR INFERIOR .CASE, METER LOWER	1				
4	90167-04021	.TORNILLO DE ROSCA HEMBRA .SCREW, TAPPING	2				
5	90159-03102	.TORNILLO CON VALONA .SCREW, WITH WASHER	3				
6	4S9-H3509-00	.ENCASTRE DE CABLE COMPLETO .SOCKET CORD ASSY	1				
7	4S9-H3517-00	.AMPOLLETA 1 (T-10 12V-1.7W) .BULB, METER 1 (T-10 12V-1.7W)	3				
8	4S9-H3517-10	.AMPOLLETA 1 (T-10 12V-1.7W) .BULB 1 (T-10 12V-1.7W BULE)	1				
9	4S9-H3518-00	.AMPOLLETA 2 (T-10 12V-3W) .BULB, METER 2 (T-10 12V-3W)	4				
10	97702-50016	TORNILLO ROSCA HEMBRA SCREW, TAPPING	3				
11	4S9-H3550-00	CABLE DE VELOCIMETRO COMPLETO SPEEDOMETER CABLE ASSY	1				

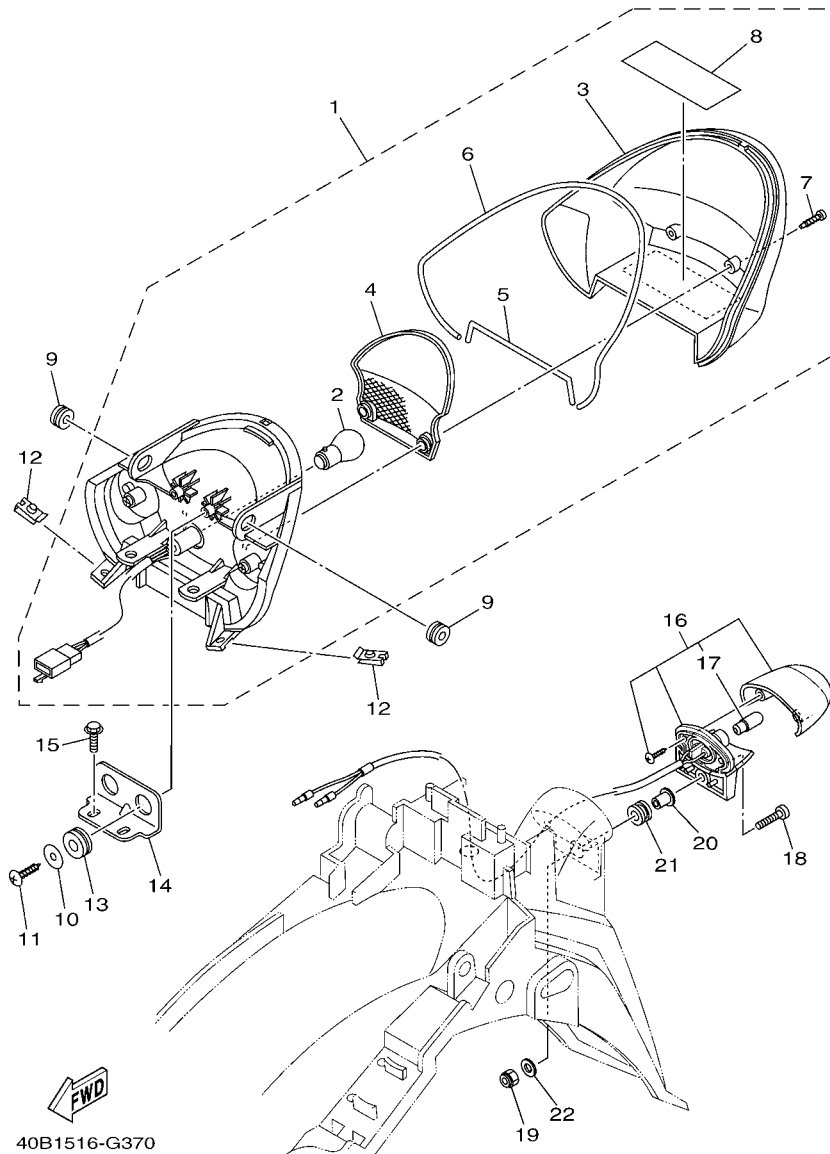
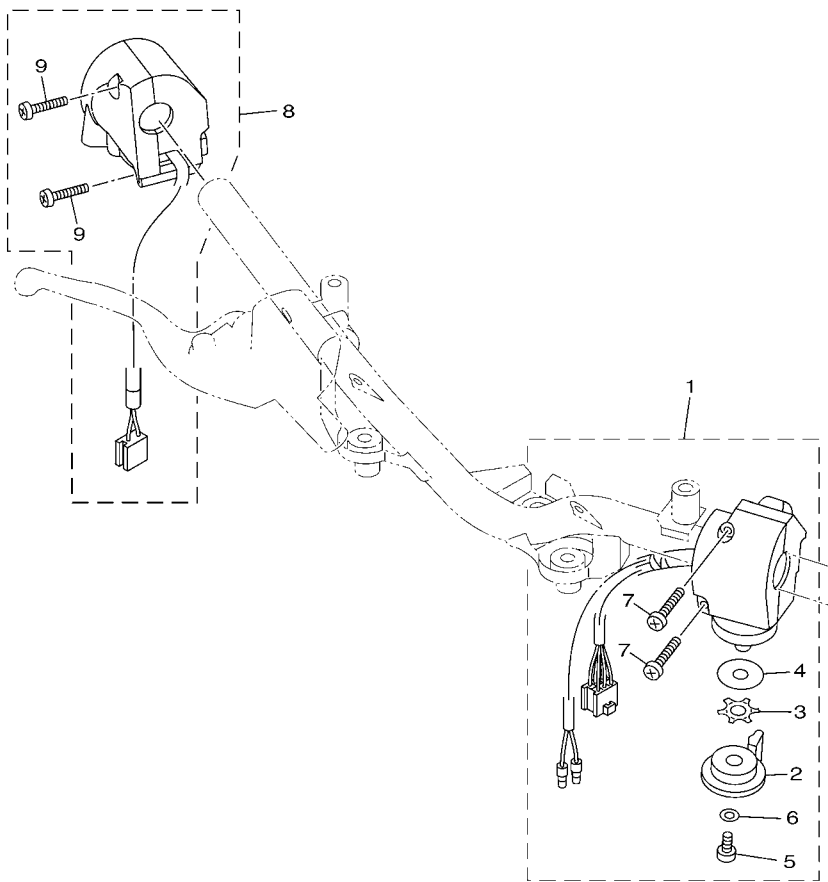

FIG. 37 LUZ DE COLA

TAILLIGHT

REF. N°	CODIGO N° PART NO.	DESCRIPCION DESCRIPTION	40B8				OBSERVACIONES REMARKS
1	40B-H4710-00	UNIDAD FARO TRASERO COMPL. TAILLIGHT UNIT ASSY	1				
2	4S9-H4714-00	.BOMBILLA (12V 21/5W) .BULB (12V 21/5W)	1				
3	40B-H4716-00	.CUBIERTA DE FARO TRASERO .COVER, TAILLIGHT	1				
4	4S9-H4721-00	.LENTE DE FARO TRASERO .LENS, TAILLIGHT	1				
5	4S9-H4712-00	.JUNTA, LUZ DE COLA .GASKET, TAILLIGHT	1				
6	4S9-H4723-00	.EMPAQUE LENTE FARO TRASERO .GASKET, TAIL LENS	1				
7	97702-40120	.TORNILLO ROSCA HEMBRA .SCREW, TAPPING	2				
8	40B-H4763-00	.CALCOMANIA CUBIERTA COLA .GRAPHIC	1				
9	90480-13005	TAPON GROMMET	2				
10	90201-06843	ARANDELA PLANA WASHER, PLATE	2				
11	97702-50014	TORNILLO ROSCA HEMBRA SCREW, TAPPING	2				
12	90183-05818	TUERCA DE RESORTE NUT, SPRING	2				
13	90480-18895	TAPON GROMMET	2				
14	4S9-H4702-00	SOPORTE DE FARO TRASERO BRACKET, TAILLIGHT	1				
15	95802-06012	TORNILLO DE REBORDE BOLT, FLANGE	2				
16	40B-H4740-00	LUZ DE LICENCIA COMPLETA LICENCE LIGHT ASSY	1				
17	40B-H4744-00	.BOMBILLA (12V-5W) .BULB (12V-5W)	1				
18	98507-05020	TORNILLO DE CABEZA PLANA SCREW, PAN HEAD	1				
19	95602-05100	TUERCA U NUT, U	1				
20	90387-05816	ESPACIADOR COLLAR	1				
21	90480-11008	TAPON GROMMET	1				
22	90201-05812	ARANDELA PLANA WASHER, PLATE	1				

FIG. 38 INTERRUPTOR DE MANILLAR&PALANC HANDLE SWITCH & LEVER



REF. N°	CODIGO N° PART NO.	DESCRIPCION DESCRIPTION	4038				OBSERVACIONES REMARKS
1	4S9-H3973-10	INTERRUPTOR DE MANIJA 3 SWITCH, HANDLE 3	1				
2	4S9-H3941-10	.PALANCA DE ARRANQUE .LEVER, STARTER	1				
3	90209-10131	.ARANDELA DE SEPARACION .WASHER	1				
4	4S9-H397X-10	.ESPACIADOR .SPACER	1				
5	98502-06008	.TORNILLO .SCREW, PAN HEAD	1				
6	92902-06200	.ARANDELA .WASHER	1				
7	98502-05025	.TORNILLO .SCREW, PAN HEAD	2				
8	40B-H3976-10	INTERRUPTOR DE MANIJA 1 SWITCH, HANDLE 1	1				
9	98502-05025	.TORNILLO .SCREW, PAN HEAD	2				

40B6516-M380

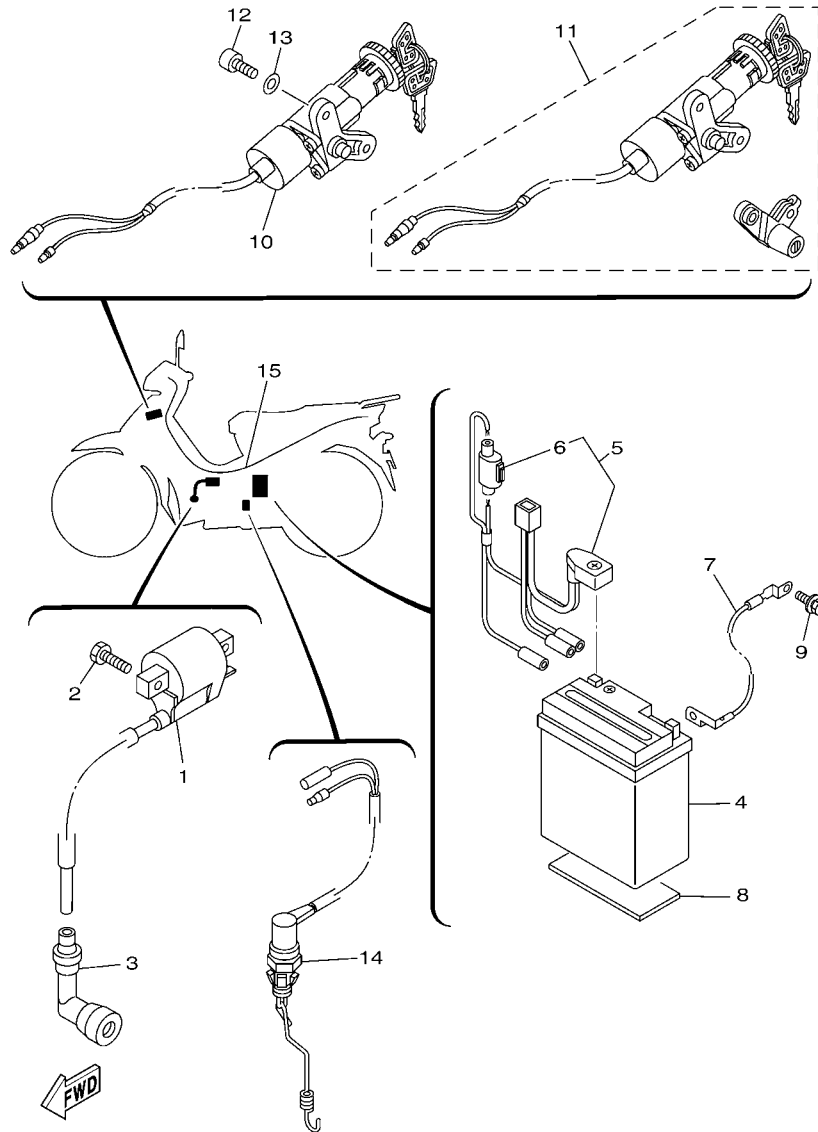

40B2516-J390

FIG. 39 EQUIPO ELECTRICO 1

ELECTRICAL 1

REF. N°	CODIGO N° PART NO.	DESCRIPCION DESCRIPTION	40B8				OBSERVACIONES REMARKS
1	4S9-H2310-00	BOBINA DE ENCENDIDO COMPLETA IGNITION COIL ASSY	1				
2	97002-06016	PERNO BOLT	2				
3	4S9-H2370-10	TAPON DE BUJIA COMPLT PLUG CAP ASSY	1				
4	40B-H2110-00	BATERIA COMPLETA (MS MTX7L-BS) BATTERY ASSY (MS MTX7L-BS)	1				
5	4S9-H2115-00	CABLE CONDUCTOR POSITIVO WIRE, PLUS LEAD	1				
6	4S9-H2151-00	.FUSIBLE (10A) .FUSE (10A)	1				
7	4S9-H2116-00	CABLE CONDUCTOR NEGATIVO WIRE, MINUS LEAD	1				
8	4S9-H2176-00	AMORTIGUADOR DAMPER	1				
9	97527-06510	PERNO CON ARANDELA BOLT, WITH WASHER	1				
10	4S9-H2501-01	LLAVE DE IGNICION COMPLT MAIN SWITCH STEERING LOCK	1				
11	4S9-XH254-01	JUEGO DE LLAVE KEY SET	1				AP AP
12	90149-06811	TORNILLO DE REGLAJE SCREW	2				
13	90201-07808	ARANDELA PLANA WASHER, PLATE	2				
14	4S9-H2530-01	INTERRUPTOR DE PARADA COMPLETO STOP SWITCH ASSY	1				
15	40B-H2590-01	CONJUNTO DE CABLES WIRE HARNESS ASSY	1				

FIG. 40 EQUIPO ELECTRICO 2

ELECTRICAL 2

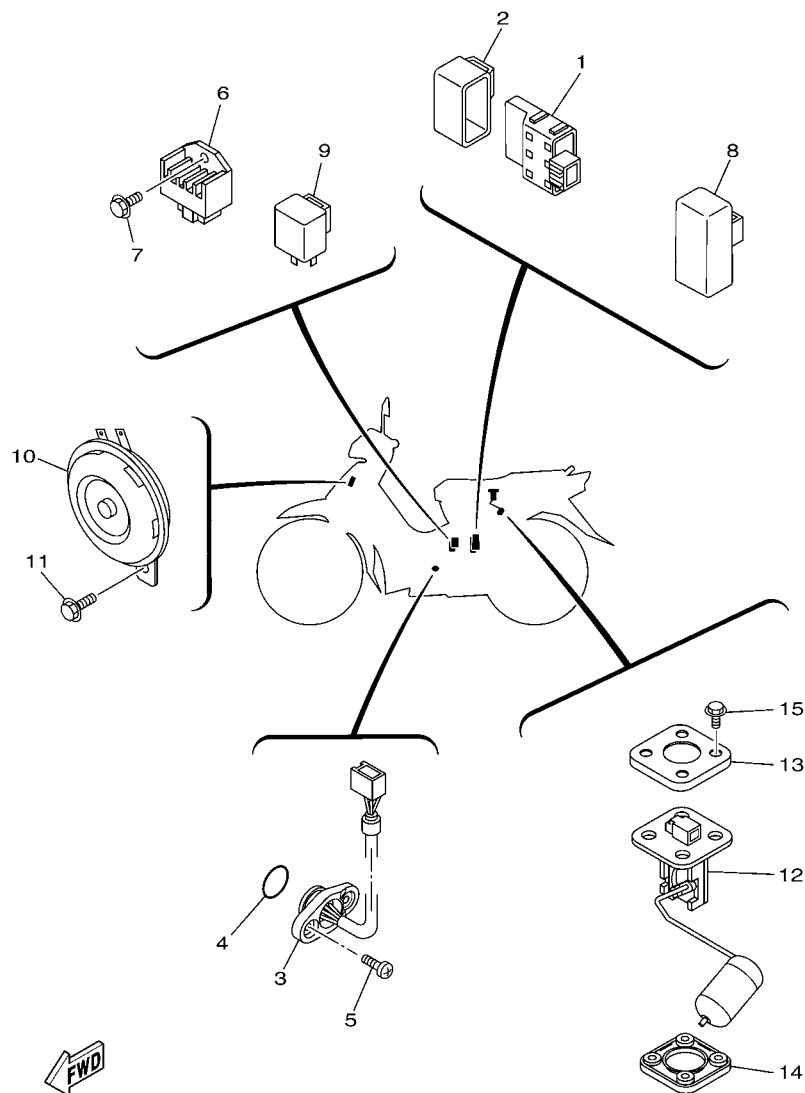

4S91415-F390

REF. Nº	CODIGO Nº PART NO.	DESCRIPCION DESCRIPTION	4038				OBSERVACIONES REMARKS
1	4S9-H5540-00	UNIDAD C.D.I. COMPLETA C.D.I. UNIT ASSY	1				
2	4S9-H5546-00	BANDA BAND	1				
3	4S9-H2540-01	INTERRUPTOR NEUTRAL COMPL. NEUTRAL SWITCH ASSY	1				
4	93210-22806	ANILLO O O-RING	1				
5	98502-05010	TORNILLO SCREW, PAN HEAD	2				
6	4S9-H1960-00	RECTIFICADOR Y REGULADOR RECTIFIER & REGULATOR ASSY	1				
7	95022-06014	PERNO, DE BRIDA BOLT, FLANGE	1				
8	4S9-H1940-00	CONJUNTO ARRANCADOR RELEVO STARTER RELAY ASSY	1				
9	4S9-H3350-00	RELE DE DESTELLADOR COMPL. FLASHER RELAY ASSY	1				
10	4S9-H3371-01	BOCINA HORN	1				
11	95802-06010	TORNILLO DE REBORDE BOLT, FLANGE	1				
12	4S9-H5752-00	UNIDAD TRANSM. MED. COMBUST. SENDER UNIT ASSY, FUEL METER	1				
13	4S9-H5757-00	SEGURO RETAINER	1				
14	4S9-H5753-01	EMPAQUE DE UNIDAD TRANSMISORA GASKET, SENDER UNIT	1				
15	90119-05802	TORNILLO CON ARANDELA BOLT, WITH WASHER	4				

INDICE NUMERICO
NUMERICAL INDEX

CODIGO Nº PART NO.	REF. Nº	CODIGO Nº PART NO.	REF. Nº	CODIGO Nº PART NO.	REF. Nº	CODIGO Nº PART NO.	REF. Nº	CODIGO Nº PART NO.	REF. Nº	CODIGO Nº PART NO.	REF. Nº
4ST-11134-11	1 - 2	40B-E4301-00	7 - 1	4S9-E5492-00	10 - 16	4S9-E8185-00	15 - 2	4S9-F3110-10	22 - 7	4S9-F4313-00	23 - 8
85L-14147-00	7 - 29	1JD-E4306-00	7 - 2	4S9-E5512-00	12 - 1	4S9-E8186-00	16 - 21		22 - 22	4S9-F4500-01	23 - 12
5AV-14390-00	7 - 28	1JD-E4321-00	7 - 4	4S9-E5524-00	12 - 3	4S9-E8337-00	16 - 13	4S9-F3111-10	22 - 15	4S9-F4514-00	23 - 3
360-24512-00	7 - 10	1JD-E4323-00	7 - 12	4S9-E5580-00	12 - 5	4S9-E8511-00	15 - 9		22 - 30	4S9-F4610-01	23 - 14
4S9-E1111-10	1 - 1	1JD-E4325-00	7 - 30	4S9-E5583-00	12 - 6	4S9-E8512-00	15 - 10	4S9-F3126-10	22 - 3	4S9-F4612-01	23 - 15
4S9-E111F-00	4 - 4	1JD-E4333-00	7 - 5	4S9-E5620-00	11 - 11	4S9-E8531-00	15 - 8	4S9-F3136-10	22 - 18	4S9-F4723-00	24 - 3
4S9-E1166-00	9 - 4	1JD-E4335-00	7 - 22	4S9-E5641-00	11 - 2	4S9-E8540-00	15 - 1	4S9-F3141-10	22 - 14	4S9-F4726-00	24 - 5
4S9-E1181-00	1 - 13	1JD-E4341-00	7 - 8	4S9-E5644-00	11 - 6	4S9-E8542-00	15 - 5		22 - 29	4S9-F4727-00	24 - 7
4S9-E1185-00	1 - 5	1JD-E4342-68	7 - 11		12 - 4	4S9-E8699-00	16 - 10	4RT-F3144-20	22 - 13	4S9-F4730-10	24 - 1
5WB-E1186-00	1 - 8	1JD-E4343-52	7 - 9	4S9-E5660-00	11 - 1	40B-F1110-02	17 - 1		22 - 28	4S9-F473R-00	24 - 8
4S9-E1310-00-B0	1 - 16	1JD-E4349-01	7 - 33	4S9-E5664-00	11 - 9	4S9-F111D-01	17 - 11	5WB-F3145-00	22 - 4	4S9-F473T-00	24 - 10
4S9-E1351-00	1 - 17	1JD-E4357-00	7 - 20	4S9-E5664-10	11 - 10	4S9-F113B-00	17 - 8		22 - 19	4S9-F4741-00	24 - 4
4S9-E1422-00	2 - 5	1JD-E4368-00	7 - 17	4S9-E5671-00	11 - 4	40B-F113J-00	18 - 14	5WB-F3147-00	22 - 16	4S9-F4742-00	24 - 23
4S9-E1603-20	2 - 11	1JD-E4371-00	7 - 21	4S9-E6135-00	13 - 24	4S9-F117K-00	24 - 17		22 - 31	4S9-F4747-00	24 - 2
4S9-E1631-10-A0	2 - 8	1JD-E4374-00	7 - 23	4S9-E6150-10	13 - 13	4S9-F117R-00	17 - 6	5WB-F3152-00	22 - 10	4S9-F4763-00	30 - 42
5WB-E1633-00	2 - 9	1JD-E4384-00	7 - 3	4S9-E6154-10	13 - 20	4S9-F139R-00	17 - 5		22 - 25	4S9-F4768-00	24 - 21
4S9-E1651-00	2 - 4	1JD-E4385-00	7 - 26	4S9-E6321-10	13 - 16	4S9-F139U-00	17 - 10	5WB-F3156-00	22 - 5	4S9-F4773-01	24 - 22
4S9-E1681-00	2 - 2	1JD-E4386-00	7 - 27	4S9-E6324-10	13 - 15	40B-F1511-00-P0	18 - 1		22 - 20	4S9-F4780-00	24 - 15
4S9-E1846-00	33 - 7	1JD-E4397-00	7 - 24	4S9-E6346-01	9 - 2	40B-F1511-00-P1	18 - 1	4S9-F3157-10	22 - 9	4S9-F478E-00	24 - 20
4S9-E2111-00	3 - 1	4S9-E4411-10	6 - 6	4S9-E6350-10	13 - 21	40B-F1511-00-P3	18 - 1		22 - 24	40B-F4875-10	24 - 25
4S9-E2114-00	3 - 4	4S9-E4412-00	6 - 8	4S9-E6351-10	13 - 17	4S9-F1518-01	18 - 5	5WB-F3158-00	22 - 11	4S9-F5160-30-WN	25 - 1
4S9-E2117-00	3 - 6	4S9-E4423-00	6 - 12	4S9-E6356-00	13 - 27	4S9-F153E-00	19 - 17		22 - 26	4S9-F5181-00	25 - 8
4S9-E2118-00	3 - 5	40B-E443E-00	6 - 14	4S9-E6357-00	13 - 26	4S9-F1556-01	18 - 2	4S9-F3170-10	22 - 8	40B-F5188-00	25 - 11
4S9-E2119-00	3 - 3	4S9-E4451-01	6 - 7	4S9-E6371-10	13 - 14	40B-F1568-S0	31 - 29		22 - 23	4S9-F5190-10	25 - 12
4S9-E2121-00	3 - 2	4S9-E4452-00	6 - 11	4S9-E6512-00	13 - 6	40B-F1611-01	18 - 9	5WB-F3181-00	22 - 12	4S9-F5321-00-WN	27 - 7
4S9-E2126-00	3 - 7	4S9-E4453-00	6 - 9	4S9-E6586-00	13 - 7	40B-F1668-20	20 - 13		22 - 27	4S9-F5338-00-WN	27 - 1
4S9-E2151-00	3 - 8	4S9-E4457-00	6 - 10	4S9-E6611-10	13 - 2	4S9-F1679-20	17 - 7	4S9-F331E-01	21 - 25	4S9-F533A-00	27 - 12
5WB-E2156-00	3 - 11	5AV-E445E-00	7 - 32	4S9-E6620-10	13 - 3	40B-F1685-00	18 - 12	4S9-F3340-10	22 - 32	4S9-F5351-00	27 - 13
5WB-E2159-00	3 - 9	1JD-E4561-00	7 - 7	4S9-E6626-10	13 - 4	4S9-F1721-00	19 - 1	4S9-F3346-10	22 - 34	4S9-F5355-00	27 - 11
4S9-E2170-10	4 - 1	1JD-E4589-00	7 - 18	4S9-E7121-10	14 - 6	4S9-F173E-30	19 - 4	4TU-F3411-00	22 - 33	4S9-F5364-00	27 - 6
4S9-E2176-00	4 - 6	5WB-E4596-00	7 - 6	4S9-E7131-10	14 - 2	4S9-F173E-40	19 - 4	5WB-F3411-00	21 - 4	4S9-F5366-00-WN	27 - 17
5WB-E2210-00	4 - 13	4S9-E4613-00	8 - 16	4S9-E7141-10	14 - 3	4S9-F173E-50	19 - 4	4KL-F3412-00	21 - 1	4S9-F5371-00	27 - 36
5WB-E2213-10	4 - 14	1DU-E4711-00	8 - 1	4S9-E7211-10	14 - 15	4S9-F173F-30	19 - 10	5WB-F3412-00	21 - 3	4S9-F5381-00	27 - 27
4S9-E2231-00	4 - 10	4S9-E4718-01	8 - 2	4S9-E7231-10	14 - 14	4S9-F173F-40	19 - 10	4S9-F3415-00	21 - 7	4S9-F5383-00	27 - 30
4S9-E2241-00	4 - 11	4S9-E4747-10	8 - 8	4S9-E7241-10	14 - 13	4S9-F173F-50	19 - 10	4S9-F3416-01	21 - 6	4S9-F5389-00	27 - 32
4S9-E3104-00	5 - 1	4S9-E4766-00	8 - 4	4S9-E7402-10	14 - 10	4S9-F194J-01	30 - 40	4S9-F3418-01	21 - 10	4S9-F5412-00	27 - 22
4S9-E3324-00	5 - 9	5WB-E4962-00	7 - 14	4S9-E7411-10	14 - 1	4S9-F2100-01-WN	20 - 1	5WG-F341E-00	21 - 2	4S9-F5435-20	27 - 21
4S9-E3325-00	5 - 2	4S9-E5113-00	10 - 11	4S9-E8101-00	16 - 1	4S9-F2123-00	20 - 2	5WG-F341E-10	21 - 5	4S9-F580U-01	26 - 4
4S9-E3329-00	5 - 4	4S9-E5150-00	9 - 1	4S9-E8110-00	16 - 24	4S9-F2141-00	20 - 4	4S9-F3461-00	21 - 17	4S9-F5827-00	26 - 15
4S9-E3411-00	5 - 8	4S9-E5155-00	9 - 6	4S9-E8113-00	16 - 25	4S9-F2151-01	20 - 3	4S9-F3472-00	21 - 27	40B-F582U-00	26 - 1
4S9-E3451-00	5 - 10	4S9-E5316-00	9 - 15	4S9-E8120-00	15 - 7	4S9-F2210-11	20 - 14	4S9-F4110-02	23 - 1	4S9-F583T-01	29 - 4
1DU-E3586-00	6 - 1	4S9-E5362-00	10 - 22	4S9-E8140-00	16 - 9	4S9-F2310-00	20 - 8	4S9-F411B-00	31 - 3	4S9-F5852-00	29 - 7
4S9-E3595-00	6 - 2	4S9-E5371-00	9 - 3	4S9-E8152-00	16 - 5	4S9-F2311-00	20 - 9		31 - 6	4S9-F5854-00	29 - 6
4FP-E4118-00	7 - 25	4S9-E5411-00	10 - 1	4S9-E8172-00	16 - 3	4S9-F2312-00	20 - 10	4S9-F4141-00	23 - 16	4S9-F5855-00	29 - 11
4JP-E4134-00	7 - 15	4S9-E5418-00	10 - 12	4S9-E8173-00	16 - 19	4S9-F2315-00	20 - 12	4S9-F414G-11	23 - 2	4S9-F5867-00	29 - 10
5WB-E4147-00	7 - 13	4S9-E5421-00	10 - 17	4S9-E8179-00	16 - 2	40B-F3100-30	22 - 1	4S9-F4188-01	23 - 17	3D9-F586F-01	29 - 13
1JD-E4197-00	7 - 34	4S9-E5451-00	10 - 2	4S9-E817A-00	16 - 20	40B-F3102-30	22 - 2	4S9-F4311-00	23 - 6	4S9-F5872-01	29 - 1
1JD-E4293-00	7 - 16	4S9-E5461-00	10 - 18	4S9-E8181-00	16 - 4	40B-F3103-30	22 - 17	4S9-F4312-10	23 - 7	4S9-F5875-01	21 - 23

INDICE NUMERICO
NUMERICAL INDEX

CODIGO Nº PART NO.	REF. Nº	CODIGO Nº PART NO.	REF. Nº	CODIGO Nº PART NO.	REF. Nº	CODIGO Nº PART NO.	REF. Nº	CODIGO Nº PART NO.	REF. Nº	CODIGO Nº PART NO.	REF. Nº
4S9-F5886-01	21 - 22	4S9-F8371-00	18 - 8	4S9-H3509-00	35 - 6	4S9-XF173-10-P0	19 - 3	90159-06867	24 - 19	90201-20266	14 - 4
4S9-F5887-01	21 - 20		31 - 23	4S9-H3510-01	35 - 1	4S9-XF173-10-P1	19 - 3	90167-04021	35 - 4		14 - 11
4KL-F5896-00	29 - 9	4S9-F8391-30	31 - 2	4S9-H3511-00	35 - 2	4S9-XF173-10-P3	19 - 3	90170-05302	3 - 10	90202-26803	21 - 9
3D9-F589F-01	29 - 14	4S9-F8391-40	31 - 2	4S9-H3517-00	35 - 7	4S9-XF174-10-P0	19 - 9	90170-06809	27 - 34	90206-14093	27 - 16
4KL-F589H-01	29 - 8	4S9-F8391-50	31 - 2	4S9-H3517-10	35 - 8	4S9-XF174-10-P1	19 - 9	90176-08812	1 - 11	90206-19027	11 - 5
4S5-F5917-00	26 - 7	4S9-F8392-30	31 - 5	4S9-H3518-00	35 - 9	4S9-XF174-10-P3	19 - 9	90179-06835	30 - 12	90209-10131	38 - 3
4S5-F5919-00	26 - 12	4S9-F8392-40	31 - 5	4S9-H353F-00	35 - 3	40B-XF339-40-P0	21 - 13	90179-08639	27 - 24	90249-12008	30 - 11
4S5-F5924-01	26 - 13	4S9-F8392-50	31 - 5	4S9-H3550-00	35 - 11	40B-XF339-50-P1	21 - 13	90179-12803	13 - 11	90280-03017	2 - 7
4S5-F5925-00	26 - 11	4S9-F8398-30	31 - 14	4S9-H3922-00	29 - 12	4S9-XF831-10-P0	31 - 1	90179-14803	13 - 25	90340-12806	5 - 6
4S5-F5937-00	26 - 8	4S9-F8398-40	31 - 14	4S9-H3936-00	18 - 19	4S9-XF831-10-P1	31 - 1	90179-25809	21 - 8	90340-14818	10 - 7
4S5-F5939-00	26 - 14	4S9-F8398-50	31 - 14		28 - 18	4S9-XF831-10-P3	31 - 1	90183-05807	18 - 6	90340-32813	10 - 9
4S9-F6113-00	28 - 4	4S9-F8399-30	31 - 19	4S9-H3941-10	38 - 2	4S9-XF832-30-P0	31 - 4		19 - 13	90387-05816	37 - 20
4S9-F6113-10	36 - 7	4S9-F8399-40	31 - 19	4S9-H3973-10	38 - 1	4S9-XF832-30-P1	31 - 4		21 - 28	90387-06063	10 - 15
4S9-F6113-20	28 - 7	4S9-F8399-50	31 - 19	40B-H3976-10	38 - 8	4S9-XF832-30-P3	31 - 4		24 - 9	90387-062M9	21 - 16
4S9-F6143-01-P0	28 - 5	4S9-F842M-00	31 - 24	4S9-H397X-10	38 - 4	4S9-XF838-10-P0	31 - 13		28 - 6	90387-06814	31 - 9
4S9-F6143-01-P2	28 - 5	4S9-F842N-00	31 - 27	4S9-H3980-01	29 - 16	4S9-XF838-10-P1	31 - 13		31 - 15	90387-06855	19 - 8
4S9-F6143-01-P3	28 - 5	40B-H1410-00	32 - 2	4S9-H3500-10	36 - 1	4S9-XF838-10-P3	31 - 13		31 - 20		19 - 15
4S9-F6145-00	28 - 8	4S9-H1450-00	32 - 1	4S9-H4314-00	36 - 2	4S9-XF839-10-P0	31 - 18	90183-05818	37 - 12	90387-06857	18 - 3
4S9-F6210-01	28 - 1	4S9-H1800-20	33 - 1	4S9-H4347-10	36 - 4	4S9-XF839-10-P1	31 - 18	90185-08818	30 - 17		21 - 12
40B-F6240-10	28 - 11	4S9-H1801-10	33 - 2	4S9-H4374-01	36 - 6	4S9-XF839-10-P3	31 - 18	90185-10807	25 - 9	90387-068E9	31 - 26
4S9-F6241-00	28 - 12	4S9-H1828-00	33 - 6	4S9-H4702-00	37 - 14	4S9-XH254-01	39 - 11	90185-12804	27 - 28	90387-068K3	6 - 17
40B-F6280-00	28 - 13	4S9-H183G-10	33 - 5	40B-H4710-00	37 - 1	90101-06818	27 - 14	90201-05812	37 - 22	90387-068K6	24 - 13
40B-F6290-00	28 - 14	4S9-H1847-00	33 - 3	4S9-H4712-00	37 - 5	90101-08820	4 - 8	90201-06078	8 - 5	90387-10817	8 - 9
40B-F6301-00	28 - 15	4S9-H1940-00	40 - 8	4S9-H4714-00	37 - 2	90101-08847	27 - 23	90201-06557	31 - 11		30 - 39
4S9-F6331-00	28 - 17	4S9-H1960-00	40 - 6	40B-H4716-00	37 - 3	90105-10036	21 - 18	90201-06816	23 - 5	90387-10828	25 - 7
4S9-F7111-01	30 - 1	40B-H2110-00	39 - 4	4S9-H4721-00	37 - 4	90105-10824	26 - 3	90201-06843	37 - 10	90387-127Y0	27 - 19
4S9-F7112-00	30 - 2	4S9-H2115-00	39 - 5	4S9-H4723-00	37 - 6	90105-10870	20 - 16	90201-07808	39 - 13	90387-12841	27 - 31
4S9-F7115-00	30 - 4	4S9-H2116-00	39 - 7	40B-H4740-00	37 - 16	90105-12802	20 - 15	90201-08043	17 - 3	90387-12844	27 - 2
4S9-F7211-00	30 - 6	4S9-H2151-00	39 - 6	40B-H4744-00	37 - 17	90109-08816	27 - 37	90201-08824	4 - 7	90387-1503D	14 - 16
4S9-F7231-00	30 - 9	4S9-H2176-00	39 - 8	40B-H4763-00	37 - 8	90109-08830	30 - 16	90201-08827	1 - 10	90387-16812	13 - 1
4S9-F7235-00	30 - 8	4S9-H2310-00	39 - 1	4S9-H5110-10	22 - 6	90109-08848	27 - 41	90201-08870	8 - 10	90387-17805	13 - 23
4S9-F7311-00	30 - 15	4S9-H2370-10	39 - 3		22 - 21	90110-06256	6 - 5	90201-088C4	8 - 7	90401-10823	29 - 2
4S9-F7411-00	30 - 19	4S9-H2501-01	39 - 10	4P7-H5130-01	18 - 17	90111-08853	26 - 2		28 - 3	90430-06817	4 - 15
4S9-F7413-00	30 - 21	4S9-H2530-01	39 - 14	4S9-H5540-00	40 - 1	90116-06820	1 - 4	90201-10669	8 - 15	90430-12227	5 - 7
4S9-F7424-00	30 - 38	4S9-H2540-01	40 - 3	4S9-H5546-00	40 - 2	90116-08824	9 - 14	90201-10831	20 - 17	90450-43802	6 - 16
4S9-F7430-01	30 - 22	40B-H2590-01	39 - 15	4S9-H5752-00	40 - 12	90119-05802	40 - 15		25 - 10	90462-10801	9 - 12
4S9-F7431-01	30 - 24	3D9-H3311-10	34 - 2	4S9-H5753-01	40 - 14	90119-05805	36 - 5	90201-108J9	29 - 3	90464-45800	28 - 19
4S9-F7433-00	30 - 25		34 - 6	4S9-H5757-00	40 - 13	90119-06869	18 - 10	90201-12030	32 - 6	90465-10833	9 - 11
4S9-F7440-01	30 - 30	4S9-H3311-10	36 - 3	4S9-W0041-01	29 - 5	90119-068A8	18 - 13	90201-12045	16 - 18	90467-09006	23 - 10
4S9-F7441-01	30 - 32	3D9-H3318-10	34 - 9	4S5-W0045-00	26 - 10	90149-06811	39 - 12	90201-127F4	16 - 14	90467-10803	23 - 9
4S9-F7444-00	30 - 33	4S9-H3330-01	34 - 1	4S5-W0047-00	26 - 6	90155-06801	5 - 5	90201-12820	13 - 10	90467-110A3	6 - 15
4S9-F7445-01	30 - 26	3D9-H3333-10	34 - 4	4S5-W0048-01	26 - 9	90159-03102	35 - 5	90201-12826	27 - 29	90467-11801	23 - 11
	30 - 34		34 - 8	4S5-W0057-00	26 - 5	90159-05805	13 - 19	90201-128C9	14 - 7	90467-13064	9 - 5
4S9-F7452-00-WN	30 - 23	3D9-H333A-00	34 - 7	4S9-WE140-00	2 - 1	90159-06842	19 - 18	90201-128D0	20 - 5	90467-13800	6 - 19
4S9-F7462-00-WN	30 - 31	4S9-H3340-01	34 - 5	4S9-WF470-00	24 - 18		21 - 15	90201-128F3	20 - 6	90468-26800	11 - 3
4S9-F8100-00	24 - 26	3D9-H334A-00	34 - 3	4S9-WF530-00	27 - 8		31 - 16	90201-15700	14 - 17	90480-01559	18 - 11
4S9-F8321-01	31 - 7	4S9-H3350-00	40 - 9	4S9-XF171-00-P0	19 - 16		31 - 21	90201-167P7	13 - 5	90480-11008	37 - 21
4S9-F8322-01	31 - 8	4S9-H3371-01	40 - 10	4S9-XF171-10-P0	19 - 16		31 - 25	90201-178D3	16 - 11	90480-12808	19 - 7

INDICE NUMERICO
NUMERICAL INDEX

CODIGO N° PART NO.	REF. N°	CODIGO N° PART NO.	REF. N°	CODIGO N° PART NO.	REF. N°	CODIGO N° PART NO.	REF. N°	CODIGO N° PART NO.	REF. N°	CODIGO N° PART NO.	REF. N°
90480-12808	19 - 14	93102-15807	11 - 13	95022-06010	21 - 21	97012-06025	11 - 12				
90480-13005	37 - 9	93102-20802	14 - 21		21 - 24	97022-08020	16 - 26				
90480-13018	31 - 10	93106-20826	25 - 3	95022-06014	40 - 7	97502-06510	20 - 11				
90480-13568	10 - 14	93106-26823	27 - 18	95022-06016	21 - 11	97522-06520	18 - 4				
90480-14806	24 - 12	93210-06806	16 - 22	95022-06025	21 - 26	97527-06510	39 - 9				
90480-18895	37 - 13	93210-108B1	4 - 2		24 - 14	97601-04114	7 - 19				
90501-02639	12 - 8	93210-14899	10 - 8	95022-06040	9 - 10	97702-40120	37 - 7				
90501-04802	13 - 9	93210-19809	10 - 23		10 - 4	97702-50012	21 - 14				
90501-05802	13 - 22	93210-22806	40 - 4		10 - 20		28 - 10				
90501-06805	15 - 6	93210-23614	33 - 4	95022-06050	10 - 5		31 - 17				
90501-10245	30 - 10	93210-25809	6 - 3		10 - 21		31 - 22				
90501-12805	16 - 17	93210-328A4	10 - 10	95022-06060	9 - 9	97702-50014	18 - 7				
90501-20804	13 - 18	93210-41014	27 - 5	95022-06080	9 - 8		19 - 2				
90506-12801	27 - 9	93210-44807	1 - 9		10 - 6		37 - 11				
90506-15802	27 - 10	93210-62802	1 - 6	95022-06090	1 - 15	97702-50016	24 - 11				
90506-20810	30 - 7	93306-001X8	14 - 9	95302-06600	27 - 15		28 - 9				
90506-20829	30 - 18	93306-002X9	4 - 3	95302-08700	27 - 39		31 - 28				
90506-35815	30 - 5	93306-054Y0	27 - 20	95307-06600	27 - 33		35 - 10				
90508-26810	11 - 8	93306-203XE	14 - 8	95602-05100	37 - 19	97702-50025	19 - 6				
90508-29007	16 - 7	93306-204XF	14 - 20	95602-08200	17 - 4		19 - 12				
90520-02801	17 - 12	93306-205YP	2 - 6	95602-10200	21 - 19	97702-50030	6 - 13				
90520-02802	17 - 13	93306-252XJ	14 - 19	95602-12200	20 - 7	97901-04116	7 - 31				
90520-05804	18 - 20	93306-300Y4	25 - 4	95702-05500	18 - 18	98502-05010	40 - 5				
90560-10292	25 - 2	93306-301XG	27 - 3	95702-06500	8 - 17	98502-05012	28 - 16				
90560-17384	13 - 12	93306-301XH	27 - 4		16 - 23	98502-05025	38 - 7				
91312-06012	4 - 5	93310-526Y6	2 - 3		24 - 6		38 - 9				
	12 - 9	93340-212Y6	16 - 15	95702-08500	8 - 11	98502-06008	38 - 5				
91312-06014	32 - 4	93342-210Y0	13 - 28	95702-10500	8 - 14	98502-06012	24 - 16				
91312-06016	4 - 12	93410-20809	14 - 5	95702-12500	32 - 5	98502-06016	1 - 7				
91312-06018	4 - 16		14 - 12	95802-06010	17 - 9	98507-05020	37 - 18				
91312-06025	6 - 4		14 - 23		40 - 11	98980-06012	8 - 3				
	29 - 15	93430-05826	5 - 3	95802-06012	37 - 15	99009-10400	15 - 11				
	32 - 3	93440-10153	1 - 3	95802-06014	23 - 13	99009-15400	14 - 18				
91402-20012	27 - 40	93450-14088	2 - 10	95802-06020	6 - 18	99009-17400	16 - 12				
	30 - 13	93604-10837	16 - 16	95802-06025	10 - 13	99009-19400	11 - 7				
91402-25015	30 - 28	93604-12831	15 - 4	95802-08045	8 - 6	99246-00100	19 - 5				
	30 - 36	93606-10801	13 - 8	95812-06020	24 - 24		19 - 11				
91402-30030	30 - 3	93608-43800	12 - 2	95812-08020	30 - 29	99530-10114	1 - 14				
91702-08042	30 - 27	93608-50149	16 - 8		30 - 37		9 - 7				
	30 - 35	93610-10174	12 - 7	95812-08120	17 - 2		9 - 13				
92902-05200	18 - 16	93822-15817	14 - 22	95822-06016	23 - 4		10 - 3				
92902-06200	38 - 6	94107-17842	25 - 5	95822-08016	30 - 20		10 - 19				
92902-08200	27 - 38	94108-17841	27 - 25		30 - 41						
92902-10200	8 - 13	94207-17808	25 - 6	95822-10045	8 - 12						
92907-06600	30 - 14		27 - 26	97002-05012	18 - 15						
92B12-06025	15 - 3	94568-B7098	27 - 35	97002-06016	39 - 2						
93101-10800	10 - 24	94568-F2086	4 - 9	97002-06020	31 - 12						
93102-12806	16 - 6	94700-00869	1 - 12	97002-08016	28 - 2						